



CITY OF SOUTH GATE



STREET TREE MASTER PLAN
November 2007

CITY OF SOUTH GATE

MASTER STREET TREE PLAN

INTRODUCTION	Section 1
SPECIES PALETTE AND PHOTOS	Section 2
2'+ PARKWAY (GROWING SPACE)	Section 3
3'+ PARKWAY (GROWING SPACE)	Section 4
5'+ PARKWAY (GROWING SPACE)	Section 5
8'+ PARKWAY (GROWING SPACE)	Section 6
STREET TREE PLANTING PLAN	Section 7
PLANTING DETAIL	Section 8
VACANT SITE LISTING	Section 9
TREE INVENTORY FREQUENCY REPORTS	Section 10
COMMUNITY OUTREACH	Section 11
SAMPLE DOOR HANGERS	Section 12
DISTRICT MAPS	Section 13
TREE ORDINANCE	Section 14
ANSI PRUNING STANDARDS (STANDARD MAINTENANCE PRACTICES)	Section 15

prepared for the City of South Gate by



Introduction

Since 2006, West Coast Arborists, Inc. has been working with the City of South Gate to develop a new Street Tree Master Plan to manage the future growth of one of the City's most valued assets, street trees. It was agreed that the Master Plan should address issues relating to the health and welfare of the City's trees as well as the reduction of infrastructure damage costs.

STEPS IN THE MASTER PLAN PROCESS

- Set goals and guidelines
- Perform a complete inventory of trees and vacant planting sites
- Create and approve a species palette
- Create a tree species planting plan
- Obtain community input
- Implement the plan

GOALS

The following goals were identified in consultation with City staff:

- Reduce infrastructure damage costs
- Reduce tree and infrastructure hazards
- Maintain existing arboricultural themes
- Fill vacant planting sites
- Increase tree canopy
- Minimize tree maintenance costs

GUIDELINES

The City was previously divided into *Neighborhoods*, *Corridors* and *Districts* during the process of creating a General Plan. *Neighborhoods* are geographic areas with common architectural and visual themes. Major arterial streets are contained in *Corridors* while commercial areas are included in *Districts*.

This plan aims to implement the Goals while maintaining consistency with current tree species where appropriate, minimizing disruption to homeowners and costs to the city. It was agreed that the most frequent currently planted tree species should become the primary designated

species if the tree was found on the Species Palette. It was also agreed that uniform recommendations should be made for a street within a Neighborhood, Corridor or District.

Infrastructure damage is often the result of an inappropriate tree species having been planted in a parkway or growing space that is too small. Every tree species can thrive in the appropriate growing space. Unfortunately, trees are often chosen for their visual appearance when young. The unanticipated consequences of this practice may not become apparent for years or decades.

Infrastructure damage costs and hazards may be reduced by substituting species, or varieties of species, that are more appropriate for the available parkway (growing space) width. Recommendations have been made for species with favorable growth characteristics, such as deeper, more compact rooting characteristics and smaller overall size. The principal means of reducing infrastructure damage is to place the “right tree in the right place.”

Several factors were considered when making species recommendations:

- Maintaining existing arboricultural themes
- Current primary species
- Type of tree
- Appropriateness to available parkway (growing space) and/or utility presence
- Species history in South Gate
- Height and spread
- Nuisance factors such as debris from flowers or seeds

PARKWAY OR GROWING SPACE

Critical to the success of any Master Street Tree Plan is an understanding of parkway size. For the purposes of this Master Plan, parkway may be defined as *growing space*. It is the minimum dimension of available planting space at an address. Parkway may take the form of the space between curb and sidewalk, cut or formed tree wells, or the spaces behind monolithic curb/sidewalk.

TREE PALETTE

A palette of tree species is no more than a list of trees with the fewest faults specific to the conditions of the street and Neighborhood, Corridor or District where they will be planted. To serve a community well, trees should be of long life and attractive at old age. They should be reasonably free of insects or diseases and should have a well behaved, deep root system that does not buckle sidewalks or enter sewer lines. They must withstand the elements and require a minimum of maintenance.

The tree species selected in consultation with the city were classified according to their suitability for a particular parkway or growing space width. Selecting a tree species that is appropriate for the growing space width and available overhead space is the best way to control long-term infrastructure repair costs.

TREE INVENTORY

A complete inventory of all the street trees and vacant planting sites located in the city's right-of-way was performed in 2006.

Total number of street trees	14,475
Total number of vacant planting sites	3,635

During the inventory, vacant planting sites were identified according to a set of criteria defined by the city:

- Tree spacing 35' - 70' maximum, consistent with existing pattern where appropriate
- Plant 30' minimum from the BCR (beginning of curb return) on the approach to an intersection, and 10' on the ECR (end of curb return) on the exit side to maintain safe sight lines
- Plant 10' minimum from street lights and power poles
- Plant 10' minimum from fire hydrants
- Plant 5' from house walks and utility meters

TREES RECOMMENDED FOR REMOVAL

During the inventory trees in poor condition, or growing in inappropriate locations were identified. Trees were recommended for possible removal according to various criteria:

Too close together, spacing criteria	8
Dead, diseased or declining	348
Poorly structured	17
Seedling or volunteer	2
Stumps	198
Total trees recommended for removal	573

Once these trees and stumps have been removed, they may also be replaced by selections from the Planting Plan.

COMMUNITY OUTREACH

Four community meetings were held where the Master Plan process was presented to South Gate residents. A public forum followed the presentation of the Planting Plan recommendations at each meeting. The prevalence of tree-related hardscape damage and the associated costs were discussed and community input solicited. A procedure was established for residents to report tree problems to the city and for homeowners to request tree maintenance or replacement.

Contained in the Master Plan are examples of community contact letters, postcards and a door hanger. These materials may be used during removal, trimming or planting operations to inform homeowners that maintenance will occur at their locations.

IMPLEMENTING THE PLANTING PROGRAM

Upon City Council approval of the plan, tree removal and replacement programs may begin, followed by hardscape repairs. When selecting a replacement tree, reference should be made to the Planting Plan for that street within a Neighborhood, Corridor or District. The resident may select from one of the three recommended species appropriate to the available parkway or growing space.

City of South Gate

Species Palette

PARKWAY (GROWING SPACE)	COMMON NAME	BOTANICAL NAME	ZONES	HEIGHT	SPREAD	TYPE
2'+	CHINESE FRINGE TREE	<i>Chionanthus retusus</i>	3-9 & 14-24	20	15	deciduous
2'+	GRAPE MYRTLE	<i>Lagerstroemia indica</i>	7-9,12-14, 18-21	25	20	deciduous
2'+	WATER GUM	<i>Tristania laurina</i>	19-24	20	10	evergreen
3'+	ARISTOCRAT PEAR	<i>Pyrus calleryana 'Aristocrat'</i>	2-9 & 14-21	30	40	deciduous
3'+	CHANTICLEER PEAR	<i>Pyrus calleryana 'Chanticleer'</i>	2-9 & 14-21	35	18	deciduous
3'+	CHITALPA	<i>Chitalpa tashkentensis</i>	7-9,12-14 & 18-21	25	25	deciduous
3'+	DANCER PEAR	<i>Pyrus betulifolia</i>	2-9 & 14-21	25	20	deciduous
3'+	HONG KONG ORCHID	<i>Bauhinia blakeana</i>	13, 19, 21, 23, 24	20	20	semi
3'+	MAGNOLIA SAINT MARY	<i>Magnolia grandiflora 'Saint Mary'</i>	4-12 & 14-24	25	20	evergreen
3'+	REDSPIRE PEAR	<i>Pyrus calleryana 'Redspire'</i>	2-9 & 14-21	35	25	deciduous
5'+	AFGHAN PINE	<i>Pinus eldarica</i>	16-18 & 21-23	60	50	evergreen
5'+	AFRICAN SUMAC	<i>Rhus lancea</i>	8, 9 & 12-24	30	30	evergreen
5'+	AUSTRALIAN WILLOW	<i>Geijera parviflora</i>	8,9 & 12-24	40	25	evergreen
5'+	BOTTLE TREE	<i>Brachychiton populneus</i>	12-24	50	40	evergreen
5'+	CHINESE PARASOL TREE	<i>Firmiana simplex</i>	5,6,8,9 & 12-24	35	25	deciduous
5'+	CHINESE PISTACHE	<i>Pistacia chinensis</i>	4-16 & 18-23	40	40	deciduous
5'+	CHINESE TALLOW TREE	<i>Sapium sebiferum</i>	8,9,12-16, 18-21	40	35	deciduous
5'+	CRYPTOCARYA RUBRA	<i>Cryptocarya rubra</i>	14-17 & 20-24	40	40	evergreen
5'+	DRAKE ELM	<i>Ulmus parvifolia 'Drake'</i>	8,9 & 12-24	60	70	semi
5'+	GOLDENRAIN TREE	<i>Koeleruteria paniculata</i>	2-21	35	25	deciduous
5'+	HOLLY OAK	<i>Quercus ilex</i>	4-24	50	50	evergreen
5'+	INCENSE CEDAR	<i>Calocedrus decurrens</i>	2-12 & 14-24	30	60	evergreen
5'+	JAPANESE PAGODA TREE	<i>Sophora japonica</i>	1-24	40	40	deciduous
5'+	MAGNOLIA MAJESTIC BEAUTY	<i>Magnolia grandiflora 'Majestic Beauty'</i>	4-12 & 14-24	40	20	evergreen
5'+	MAGNOLIA SAMUEL SOMMER	<i>Magnolia grandiflora 'Samuel Sommer'</i>	4-12 & 14-24	40	30	evergreen
5'+	MAIDENHAIR TREE	<i>Ginkgo biloba 'Autumn Gold'</i>	1,10,12 & 14-24	60	40	deciduous
5'+	MINDINAO GUM	<i>Lucalyptus deglupta</i>	19-24	80	30	evergreen
5'+	NICHOLS WILLOW-LEAFED PEPPERMINT	<i>Lucalyptus nicholii</i>	5,6 & 8-24	40	40	evergreen
5'+	PINK TRUMPET TREE	<i>Tabebuia avellanedae</i>	15,16 & 20-24	30	30	deciduous
5'+	PURPLE ORCHID TREE	<i>Bauhinia variegata</i>	13 & 18-24	30	20	semi
5'+	RED IRONBARK	<i>Lucalyptus sideroxylon</i>	5,6 & 8-24	60	40	evergreen
5'+	SOUR GUM	<i>Nyssa sylvatica</i>	3-10 & 14-21	50	25	deciduous
5'+	TRUE GREEN ELM	<i>Ulmus parvifolia 'True Green'</i>	8,9 & 12-24	60	70	semi
5'+	TULIP TREE	<i>Liriodendron tulipifera</i>	1-12 & 14-23	80	40	deciduous
8'+	BRISBANE BOX	<i>Lophostemon confertus</i>	19-24	60	40	evergreen

City of South Gate

Species Palette

PARKWAY (GROWING SPACE)	COMMON NAME	BOTANICAL NAME	ZONES	HEIGHT	SPREAD	TYPE
8'+	CALIFORNIA CHRISTMAS TREE	<i>Cedrus deodara</i>	2-12 & 14-24	80	40	evergreen
8'+	CAMPHOR TREE	<i>Cinnamomum camphora</i>	8,9 & 12-24	50	60	evergreen
8'+	CANARY ISLAND PINE	<i>Pinus canariensis</i>	16-18 & 21-23	80	50	evergreen
8'+	CHINESE FLAME TREE	<i>Koelreuteria bipinnata</i>	8-24	50	50	deciduous
8'+	CHINESE HACKBERRY	<i>Celtis sinensis</i>	8-16 & 18-20	50	50	deciduous
8'+	COAST LIVE OAK	<i>Quercus agrifolia</i>	7-10 & 12-24	70	80	evergreen
8'+	FERN PINE	<i>Podocarpus gracilior</i>	8,9 & 13-24	60	60	evergreen
8'+	FRONTIER ELM	<i>Ulmus parvifolia 'Frontier'</i>	1-11, 14-21	80	50	deciduous
8'+	LEMON-SCENTED GUM	<i>Eucalyptus citriodora</i>	5,6 & 8-24	50	100	evergreen
8'+	LONDON PLANE TREE	<i>Platanus acerifolia</i>	2-24	60	40	deciduous
8'+	ROUND-LEAFED SWEETGUM	<i>Liquidambar styraciflua 'Rotundiloba'</i>	14-24	60	35	deciduous
8'+	SAWLEAF ZELKOVA	<i>Zelkova serrata</i>	3-21	40	40	deciduous
8'+	SOUTHERN LIFE OAK	<i>Quercus virginiana</i>	4-24	60	100	evergreen
8'+	SOUTHERN MAGNOLIA	<i>Magnolia grandiflora</i>	4-12 & 14-24	60	40	evergreen
8'+	TIPU TREE	<i>Tipuana tipu</i>	13-16 & 18-24	50	60	semi

CRAPE MYRTLE

Lagerstroemia indica



Zones

7-9,12-14, 18-21

Height

25

Spread

20

Type

deciduous

Flower/Seed

white, pink, red flowers; 1/4" brown seed capsules

Growth

moderate-fast

Soil

any

Parkway

2'+



CHINESE FRINGE TREE

Chionanthus retusus



Zones

3-9 & 14-24

Height

20

Spread

15

Type

deciduous

Flower/Seed

4" white flower clusters

Growth

moderate

Soil

most

Parkway

2'+

Availability

specialty



WATER GUM

Tristania laurina

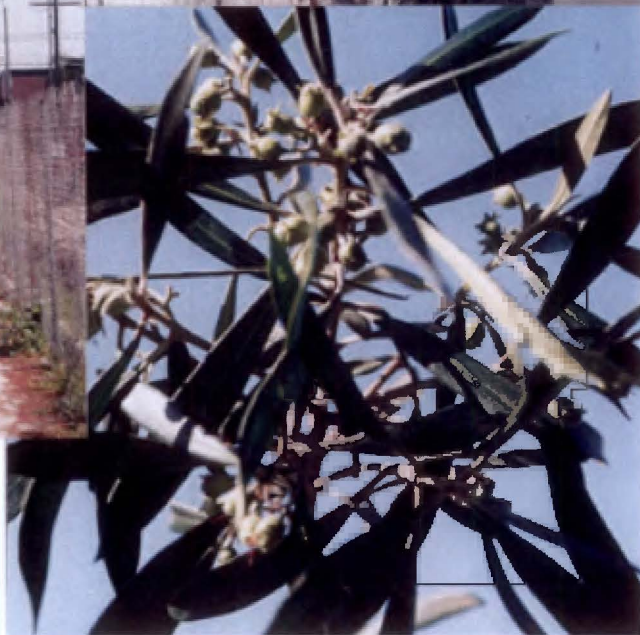

Zones

19-24

Height

20

Spread

10

Type

evergreen

Flower/Seed

small yellowish flowers; 1/4" seed capsules

Growth

moderate

Soil

Parkway

2'+



ARISTOCRAT PEAR
Pyrus calleryana 'Aristocrat'



Zones
2-9 & 14-21

Height
30

Spread
40

Type
deciduous

Flower/Seed
showy white flowers

Growth
moderate

Soil
any

Parkway
3'+



CHITALPA
Chitalpa tashkentensis



Zones

7-9, 12-14 & 18-21

Height

25

Spread

25

Type

deciduous

Flower/Seed

2-3" pink & white flowers

Growth

moderate

Soil

well drained

Parkway

3'+



CHANTICLEER PEAR
Pyrus calleryana 'Chanticleer'



Zones

2-9 & 14-21

Height

35

Spread

18

Type

deciduous

Flower/Seed

showy white flowers

Growth

moderate

Soil

any

Parkway

3'+



DANCER PEAR

Pyrus betulifolia



Zones

2-9 & 14-21

Height

25

Spread

20

Type

deciduous

Flower/Seed

inconspicuous white flowers

Growth

moderate

Soil

Parkway

3'+



HONG KONG ORCHID TREE

Bauhinia blakeana



Zones

13,19,21, 23, 24

Height

20

Spread

20

Type

semi

Flower/Seed

6" pink flower

Growth

moderate

Soil

Parkway

3'+

Availability

specialty



SAINT MARY MAGNOLIA

Magnolia g. 'St. Mary'



Zones

4-12 & 14-24

Height

25

Spread

20

Type

evergreen

Flower/Seed

8-10" white flowers

Growth

moderate

Soil

no clay

Parkway

3'+

Availability

specialty



REDSPIRE PEAR
Pyrus calleryana 'Redspire'



Zones

2-9 & 14-21

Height

35

Spread

25

Type

deciduous

Flower/Seed

showy white flowers

Growth

moderate

Soil

any

Parkway

3+



AFGHAN PINE

Pinus eldarica



Zones

16-18 & 21-23

Height

60

Spread

50

Type

evergreen

Flower/Seed

3" reddish-brown cones

Growth

moderate

Soil

Parkway

5'+



AUSTRALIAN WILLOW

Geijera parviflora



Zones

8,9 & 12-24

Height

40

Spread

25

Type

evergreen

Flower/Seed

small insignificant flowers

Growth

moderate

Soil

well drained

Parkway

5'+

Availability

specialty



AFRICAN SUMAC

Rhus lancea



Zones

8,9 & 12-24

Height

30

Spread

30

Type

evergreen

Flower/Seed

inconspicuous flowers; clusters of 1/4" yellow-red berries

Growth

moderate

Soil

Parkway

5'+



BOTTLE TREE

Brachychiton populneus



Zones

12-24

Height

50

Spread

30

Type

evergreen

Flower/Seed

1" white flowers; black seed pods

Growth

moderate

Soil

any

Parkway

5'+



CHINESE PARASOL TREE

Firmiana simplex



Zones

5,6,8,9 & 12-24

Height

35

Spread

25

Type

deciduous

Flower/Seed

greenish-white flowers; seed pods

Growth

moderate

Soil

no clay

Parkway

5'+



CHINESE PISTACHE

Pistacia chinensis



Zones
4-16 & 18-23

Height
40

Spread
40

Type
deciduous

Flower/Seed
clusters of 1/4" red-black fruit

Growth
moderate

Soil
well drained

Parkway
5'+

Availability
specialty



CHINESE TALLOW TREE

Sapium sebiferum



Zones

8,9,12-16, 18-21

Height

40

Spread

35

Type

deciduous

Flower/Seed

tiny yellow flowers; small grey fruit

Growth

fast

Soil

most

Parkway

5'+

Availability

specialty



CRYPTOCARYA RUBRA

Cryptocarya rubra



Zones

14-17 & 20-24

Height

40

Spread

40

Type

evergreen

Flower/Seed

small green flower clusters; small fruit

Growth

moderate

Soil

Parkway

5'+



DRAKE ELM
Ulmus p. 'Drake'



Zones
8,9 & 12-24

Height
60

Spread
70

Type
semi

Flower/Seed
inconspicuous seed capsules

Growth
moderate-fast

Soil
any

Parkway
5'+



GOLDENRAIN TREE

Koelreuteria paniculata



Zones

2-21

Height

35

Spread

25

Type

deciduous

Flower/Seed

yellow flower clusters, red seed pods

Growth

moderate-fast

Soil

any

Parkway

5'+



HOLLY OAK

Quercus ilex



Zones

4-24

Height

50

Spread

50

Type

evergreen

Flower/Seed

1-1 1/2" acorns

Growth

moderate-fast

Soil

most

Parkway

5'+



INCENSE CEDAR

Calocedrus decurrens



Zones

2-12, 14-24

Height

30

Spread

60

Type

evergreen

Flower/Seed

1" brown fruit

Growth

slow

Soil

Parkway

5'+



JAPANESE PAGODA TREE

Sophora japonica



Zones

1-24

Height

40

Spread

40

Type

deciduous

Flower/Seed

1/2" flowers in 12" clusters; 2-4" seed pods

Growth

slow

Soil

any

Parkway

5'+



MAJESTIC BEAUTY MAGNOLIA

Magnolia g. 'Majestic Beauty'



Zones

4-12 & 14-24

Height

40

Spread

20

Type

evergreen

Flower/Seed

12" white flowers

Growth

moderate

Soil

no clay

Parkway

5'+

Availability

specialty



MINDANAO GUM
Eucalyptus deglupta



Zones

19-24

Height

80

Spread

30

Type

evergreen

Flower/Seed

small capsules in clusters

Growth

fast

Soil

no clay

Parkway

5'+



NICHOL'S WILLOW LEAFED PEPPERMINT

Eucalyptus nicholii



Zones

5,6 & 8-24

Height

40

Spread

40

Type

evergreen

Flower/Seed

small white flowers, capsules in clusters

Growth

fast

Soil

Parkway

5'+



LAVENDER TRUMPET TREE

Tabebuia avellanedae



Zones

15,16 & 20-24

Height

30

Spread

30

Type

deciduous

Flower/Seed

2-3" white, purple to pink flowers

Growth

fast

Soil

most

Parkway

5'+

Availability

specialty



PURPLE ORCHID TREE

Bauhinia variegata



Zones

13 & 18-24

Height

30

Spread

20

Type

semi

Flower/Seed

3" purple flowers; beans

Growth

moderate

Soil

no clay

Parkway

5'+



RED IRONBARK
Eucalyptus sideroxylon



Zones

5,6 & 8-24

Height

60

Spread

40

Type

evergreen

Flower/Seed

pink or white flowers; 3/8" capsules in clusters

Growth

fast

Soil

Parkway

5'+



TRUE GREEN ELM

Ulmus p. 'True Green'



Zones

8,9 & 12-24

Height

60

Spread

70

Type

semi

Flower/Seed

inconspicuous seed capsules

Growth

moderate-fast

Soil

any

Parkway

5'+



SAMUEL SOMMER MAGNOLIA

Magnolia g. 'Samuel Sommer'



Zones

4-12 & 14-24

Height

40

Spread

30

Type

evergreen

Flower/Seed

10-14" white flowers

Growth

moderate

Soil

no clay

Parkway

5'+

Availability

specialty



TULIP TREE

Liriodendron tulipifera



Zones

1-12 & 14-23

Height

80

Spread

40

Type

deciduous

Flower/Seed

2" yellow-orange flowers, not showy

Growth

moderate-fast

Soil

Parkway

5'+

Availability

specialty



CANARY ISLAND PINE

Pinus canariensis



Zones

16-18 & 21-23

Height

80

Spread

50

Type

evergreen

Flower/Seed

4-9" brown cones

Growth

moderate

Soil

Parkway

8'+



CHINESE FLAME TREE

Koelreuteria bipinnata



Zones

8-24

Height

50

Spread

50

Type

deciduous

Flower/Seed

yellow flower clusters, salmon-colored 2" seed pods

Growth

fast

Soil

any

Parkway

8'+



CHINESE HACKBERRY

Celtis sinensis



Zones

8-16, 18-20

Height

50

Spread

50

Type

deciduous

Flower/Seed

inconspicuous flowers

Growth

moderate

Soil

tolerates alkaline

Parkway

8'+



COAST LIVE OAK
Quercus agrifolia



Zones

7-10 & 12-24

Height

70

Spread

80

Type

evergreen

Flower/Seed

3/4-1 1/2" acorns

Growth

moderate

Soil

Parkway

8'+



DEODAR CEDAR

Cedrus deodara



Zones

2-12 & 14-24

Height

80

Spread

40

Type

evergreen

Flower/Seed

3-5" cones, catkins

Growth

moderate

Soil

Parkway

8'+



FERN PINE
Podocarpus gracilior



Zones
8,9 & 13-24

Height
60

Spread
60

Type
evergreen

Flower/Seed
1/2-1" round fleshy fruit

Growth
moderate

Soil
most

Parkway
8'+



LEMON-SCENTED GUM

Eucalyptus citriodora



Zones

5,6 & 8-24

Height

50

Spread

100

Type

evergreen

Flower/Seed

small white flowers; capsules in clusters

Growth

fast

Soil

any

Parkway

8'+



LONDON PLANE

Platanus acerifolia



Zones

2-24

Height

60

Spread

40

Type

deciduous

Flower/Seed

1" round seed balls

Growth

fast

Soil

Parkway

8'+



ROUND-LEAFED SWEETGUM

Liquidambar s. 'Rotundiloba'



Zones

14-24

Height

60

Spread

35

Type

deciduous

Flower/Seed

no flowers or seed pods

Growth

moderate

Soil

Parkway

8+

Availability

specialty



BRISBANE BOX

Lophostemon confertus



Zones

19-24

Height

60

Spread

40

Type

evergreen

Flower/Seed

3/4" white flowers in clusters; 3/8" brown capsules

Growth

moderate-fast

Soil

any

Parkway

8'+



CAMPHOR TREE

Cinnamomum camphora



Zones

8,9 & 12-24

Height

50

Spread

60

Type

evergreen

Flower/Seed

inconspicuous small fruit

Growth

moderate

Soil

most

Parkway

8'+



SAWLEAF ZELKOVA

Zelkova serrata



Zones

3-21

Height

40

Spread

40

Type

deciduous

Flower/Seed

inconspicuous seed capsules

Growth

moderate-fast

Soil

any

Parkway

8'+



SOUTHERN LIVE OAK

Quercus virginiana



Zones

4-24

Height

60

Spread

100

Type

evergreen

Flower/Seed

1" acorns

Growth

moderate-fast

Soil

deep

Parkway

8'+



SOUTHERN MAGNOLIA

Magnolia grandiflora



Zones

4-12 & 14-24

Height

60

Spread

40

Type

evergreen

Flower/Seed

8-10" white flowers

Growth

moderate

Soil

no clay

Parkway

8'+



TIPU
Tipuana tipu



Zones

13-16 & 18-24

Height

50

Spread

60

Type

semi

Flower/Seed

deep yellow flowers in clusters; 2 1/2" seed pods

Growth

fast

Soil

Parkway

8'+



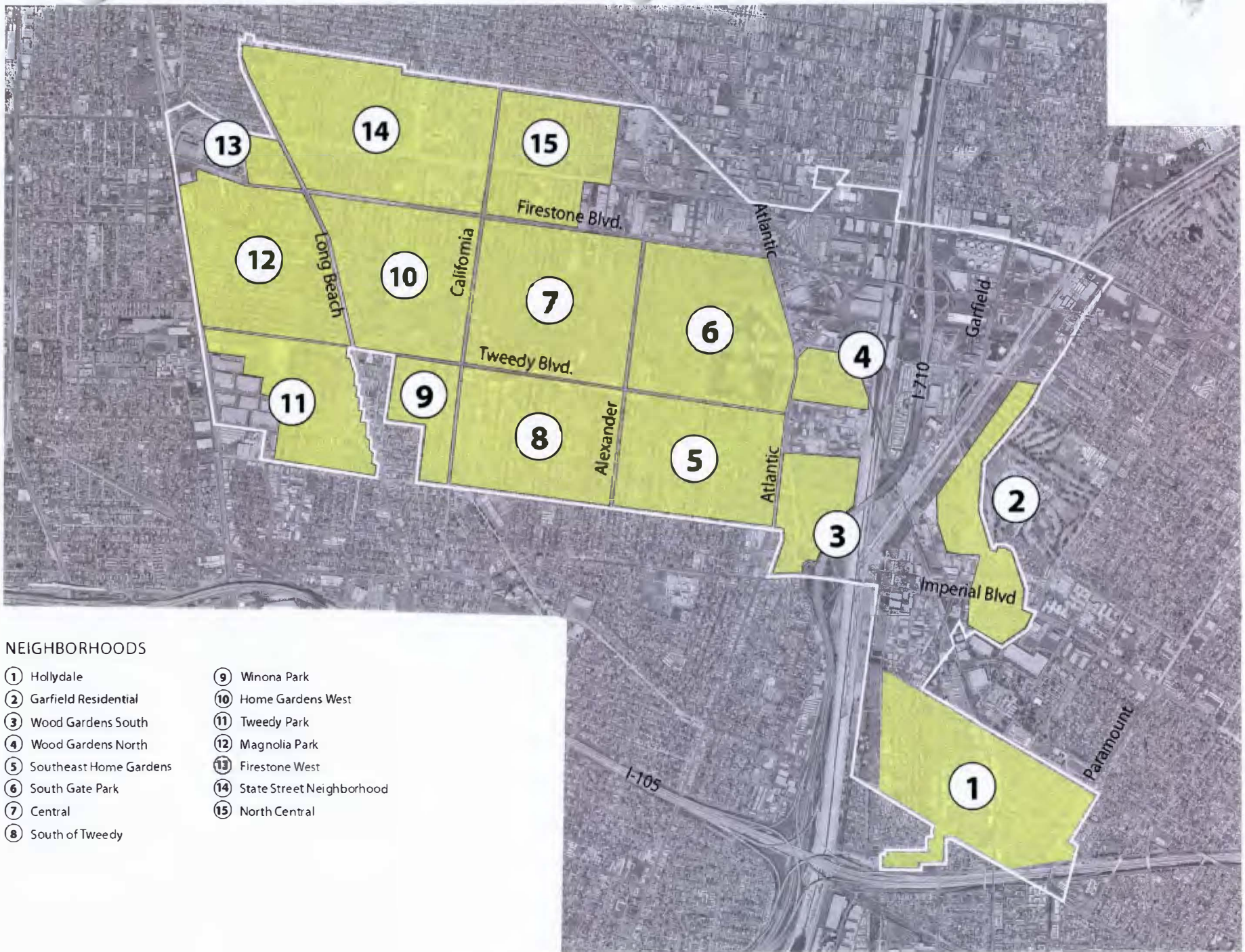

NEIGHBORHOODS

- ① Hollydale
- ② Garfield Residential
- ③ Wood Gardens South
- ④ Wood Gardens North
- ⑤ Southeast Home Gardens
- ⑥ South Gate Park
- ⑦ Central
- ⑧ South of Tweedy
- ⑨ Winona Park
- ⑩ Home Gardens West
- ⑪ Tweedy Park
- ⑫ Magnolia Park
- ⑬ Firestone West
- ⑭ State Street Neighborhood
- ⑮ North Central

**Figure 3-5
Districts and
Corridors**

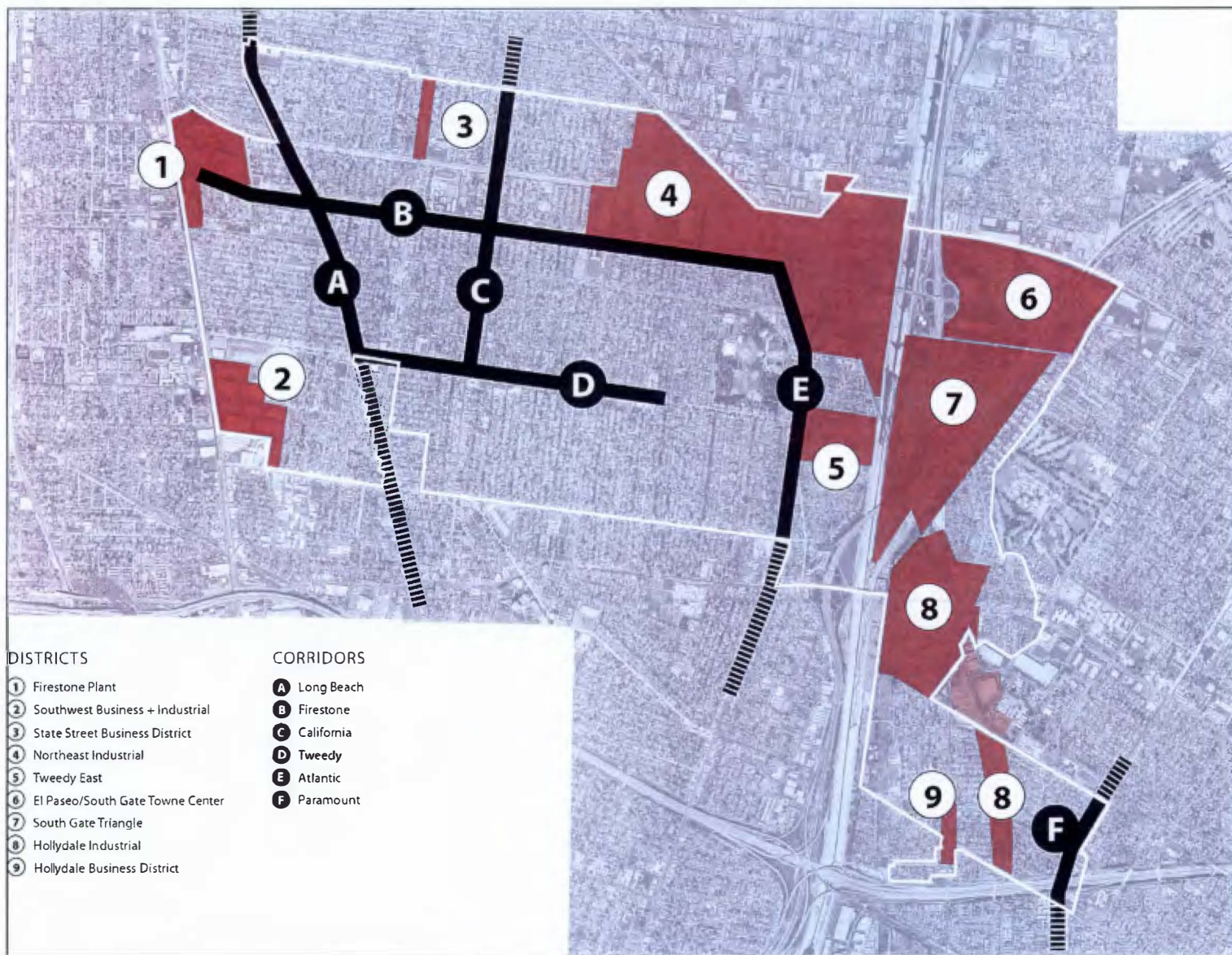

Source: Raimi & Associates, 2006

**South Gate General
Plan 2030**
Issues and Opportunities
Report



City of South Gate
Street Tree Planting Plan
November 2007

STREET	GENERAL PLAN AREA	CURRENT PRIMARY SPECIES	2-3FT PARKWAYS (GROWING SPACES)			5FT PARKWAYS (GROWING SPACES)			8FT PARKWAYS (GROWING SPACES)		
			RECOMMENDATION 1	RECOMMENDATION 2	RECOMMENDATION 3	RECOMMENDATION 1	RECOMMENDATION 2	RECOMMENDATION 3	RECOMMENDATION 1	RECOMMENDATION 2	RECOMMENDATION 3
ABBOTT RD	Neighborhood 3	PURPLE ORCHID TREE				PURPLE ORCHID TREE	BOTTLE TREE	GOLDENRAIN TREE	PURPLE ORCHID TREE	CHINESE FLAME TREE	SOUTHERN MAGNOLIA
ADELLA AV	Neighborhood 3	ARIZONA ASH				TRUE GREEN ELM	CHINESE PISTACHE	INCENSE CEDAR			
ADELLA AV	Neighborhood 4	CHINESE ELM				TRUE GREEN ELM	JAPANESE PAGODA TREE	CHINESE TALLOW TREE			
ALAMEDA ST	Neighborhood 11	BOTTLE TREE	MAGNOLIA SAINT MARY	REDSPIRE PEAR	BOTTLE TREE						
ALAMEDA ST	Neighborhood 12	AUSTRALIAN WILLOW				AUSTRALIAN WILLOW	MAGNOLIA SAMUEL SOMMER	HOLLY OAK			
ALDRICH RD	Neighborhood 3	CHINESE PISTACHE				CHINESE PISTACHE	CHINESE TALLOW TREE	GOLDENRAIN TREE			
ALEXANDER AV	Neighborhood 5	LEMON BOTTLEBRUSH				GRAPE MYRTLE	AFRICAN SUMAC	GOLDENRAIN TREE			
ALEXANDER AV	Neighborhood 6	CHINESE ELM				TRUE GREEN ELM	HOLLY OAK	BOTTLE TREE			
ALEXANDER AV	Neighborhood 7	CHINESE ELM				TRUE GREEN ELM	HOLLY OAK	MINDANAO GUM			
ALEXANDER AV	Neighborhood 8	LONDON PLANE				TRUE GREEN ELM	HOLLY OAK	SOUR GUM			
ALMIRA RD	Neighborhood 3	GRAPE MYRTLE				GRAPE MYRTLE	PURPLE ORCHID TREE	CHINESE PISTACHE			
AMERY AV	Neighborhood 2	GRAPE MYRTLE				GRAPE MYRTLE	RED IRONBARK	GOLDENRAIN TREE			
ANAHURST RD	Neighborhood 3	ARIZONA ASH				GRAPE MYRTLE	CHINESE PISTACHE	MAIDENHAIR TREE			
ANNETT AV	Neighborhood 5	CHINESE ELM				DRAKE ELM	CHINESE PISTACHE	GRAPE MYRTLE			
ANNETTA AV	Neighborhood 6	EUROPEAN HACKBERRY				DRAKE ELM	CHINESE PISTACHE	GRAPE MYRTLE			
ARDMORE AV	Neighborhood 13	SOUTHERN MAGNOLIA				MAGNOLIA SAMUEL SOMMER	TULIP TREE	BOTTLE TREE			
ARDMORE AV	Neighborhood 14	SOUTHERN MAGNOLIA				MAGNOLIA SAMUEL SOMMER	TULIP TREE	BOTTLE TREE			
ARDMORE AV	Neighborhood 15	WEEPING FIG				MAGNOLIA SAMUEL SOMMER	TULIP TREE	BOTTLE TREE			
ATLANTIC AV	Corridor E	CAROB	GRAPE MYRTLE	ARISTOCRAT PEAR	WATER GUM	MINDANAO GUM	AUSTRALIAN WILLOW	MAGNOLIA SAMUEL SOMMER	COAST LIVE OAK	BRISBANE BOX	LONDON PLANE TREE
ATLANTIC AV	Neighborhood 4	LEMON BOTTLEBRUSH	CHITALPA	MAGNOLIA SAINT MARY	WATER GUM	MAGNOLIA MAJESTIC BEAUTY	AFRICAN SUMAC	CRYPTOCARYA RUBRA			
BATAVIA RD	Neighborhood 3	ARIZONA ASH				GOLDENRAIN TREE	JAPANESE PAGODA TREE	CHINESE PARASOL TREE			
BEAK AV	Neighborhood 2	GRAPE MYRTLE				GRAPE MYRTLE	AUSTRALIAN WILLOW	PURPLE ORCHID TREE			
BEAUDINE AV	Neighborhood 12	WEEPING FIG				TULIP TREE	MAIDENHAIR TREE	MINDANAO GUM			
BEECHWOOD AV	Neighborhood 14	CAJEPUT TREE				LAVENDER TRUMPET TREE	AFGHAN PINE	NICHOLS WILLOW LEAFED PEPPERMINT			
BELMONT RD	Neighborhood 3	RAYWOOD ASH				CHINESE PISTACHE	GOLDENRAIN TREE	NICHOLS WILLOW LEAFED PEPPERMINT			
BORWICK AV	District 8	LEMON BOTTLEBRUSH	CHINESE FRINGE TREE	GRAPE MYRTLE	WATER GUM						
BOWMAN AV	Neighborhood 7	GRAPE MYRTLE	GRAPE MYRTLE	CHITALPA	HONG KONG ORCHID TREE	MAGNOLIA SAMUEL SOMMER	BOTTLE TREE	MAIDENHAIR TREE			
BOWMAN AV	Neighborhood 8	SOUTHERN MAGNOLIA				MAGNOLIA SAMUEL SOMMER	BOTTLE TREE	MAIDENHAIR TREE			
BROOKDALE RD	Neighborhood 3	ARIZONA ASH				CHINESE TALLOW TREE	CHINESE PISTACHE	INCENSE CEDAR			
BRYSON AV	Neighborhood 5	JACARANDA				GOLDENRAIN TREE	JAPANESE PAGODA TREE	ARISTOCRAT PEAR			
BRYSON AV	Neighborhood 6	JACARANDA	GRAPE MYRTLE	ARISTOCRAT PEAR	CHINESE FRINGE TREE	CHINESE PISTACHE	GOLDENRAIN TREE	HOLLY OAK			
BURKE AV	Neighborhood 6	INDIAN LAUREL FIG				DRAKE ELM	MAIDENHAIR TREE	HOLLY OAK			
CALDEN AV	Neighborhood 12	AUSTRALIAN WILLOW				AUSTRALIAN WILLOW	DRAKE ELM	JAPANESE PAGODA TREE			
CALIFORNIA AV	Corridor C	CHINESE PISTACHE	CHINESE FRINGE TREE	CHANTICLEER PEAR	CHITALPA	CHINESE PISTACHE	AFGHAN PINE	DRAKE ELM	SAWLEAF ZELKOVA	COAST LIVE OAK	BRISBANE BOX
CALIFORNIA AV	Neighborhood 10	LEMON BOTTLEBRUSH	MAGNOLIA SAINT MARY	DANCER PEAR	WATER GUM						
CALIFORNIA AV	Neighborhood 7	LEMON BOTTLEBRUSH	MAGNOLIA SAINT MARY	DANCER PEAR	WATER GUM						
CALIFORNIA AV	Neighborhood 9	WHITE MULBERRY	MAGNOLIA SAINT MARY	DANCER PEAR	WATER GUM						
CAPISTRANO AV	Neighborhood 11	COAST LIVE OAK	GRAPE MYRTLE	MAGNOLIA SAINT MARY	CHITALPA	HOLLY OAK	MAGNOLIA SAMUEL SOMMER	CRYPTOCARYA RUBRA			
CASSINA AV	Neighborhood 2	GRAPE MYRTLE				GRAPE MYRTLE	CHINESE PISTACHE	AFRICAN SUMAC			

City of South Gate

Street Tree Planting Plan

November 2007

STREET	GENERAL PLAN AREA	CURRENT PRIMARY SPECIES	2-3FT PARKWAYS (GROWING SPACES)			5FT PARKWAYS (GROWING SPACES)			8FT PARKWAYS (GROWING SPACES)		
			RECOMMENDATION 1	RECOMMENDATION 2	RECOMMENDATION 3	RECOMMENDATION 1	RECOMMENDATION 2	RECOMMENDATION 3	RECOMMENDATION 1	RECOMMENDATION 2	RECOMMENDATION 3
CENTER ST	District 8	WEeping BOTTLEBRUSH	ARISTOCRAT PEAR	CHITALPA	MAGNOLIA SAINT MARY	AUSTRALIAN WILLOW	RED IRONBARK	DRAKE ELM			
CENTER ST	Neighborhood 1	LEMON BOTTLEBRUSH				MAGNOLIA MAJESTIC BEAUTY	BOTTLE TREE	LAVENDER TRUMPET TREE			
CENTURY BL	District 2	CHINESE ELM							TRUE GREEN ELM	CANARY ISLAND PINE	SOUTHERN LIVE OAK
CENTURY BL	Neighborhood 1	CAROB				AFGHAN PINE	MAGNOLIA SAMUEL SOMMER	NICHOLS WILLOW LEAFED PEPPERMINT			
CENTURY BL	Neighborhood 11	JACARANDA				RED IRONBARK	GOLDENRAIN TREE	HOLLY OAK	FERN PINE	CHINESE FLAME TREE	SAWTOOTH ZELKOVA
CHEROKEE AV	Neighborhood 11	FERN PINE				HOLLY OAK	CHINESE PISTACHE	AUSTRALIAN WILLOW			
CHEROKEE AV	Neighborhood 9	CRAPE MYRTLE	CRAPE MYRTLE	CHINESE FRINGE TREE	CHITALPA	CRAPE MYRTLE	HOLLY OAK	CHINESE PISTACHE			
CHESTNUT AV	Neighborhood 14	CRAPE MYRTLE				CRAPE MYRTLE	HOLLY OAK	NICHOLS WILLOW LEAFED PEPPERMINT			
CLOVERLAWN DR	Neighborhood 1	SOUTHERN LIVE OAK				HOLLYOAK	MAGNOLIA SAMUEL SOMMER	GOLDENRAIN TREE			
COMMERCIAL PL	Neighborhood 14	CRAPE MYRTLE				CRAPE MYRTLE	BOTTLE TREE	MAGNOLIA MAJESTIC BEAUTY			
CYPRESS AV	Neighborhood 10	SOUTHERN MAGNOLIA				MAGNOLIA SAMUEL SOMMER	TULIP TREE	BOTTLE TREE			
CYPRESS AV	Neighborhood 14	SOUTHERN MAGNOLIA				MAGNOLIA SAMUEL SOMMER	TULIP TREE	BOTTLE TREE			
DE PALMA ST	District 6	MEXICAN FAN PALM				PURPLE ORCHID TREE	HOLLY OAK	GOLDENRAIN TREE			
DEARBORN AV	Neighborhood 10	INDIAN LAUREL FIG	ARISTOCRAT PEAR	CHITALPA	MAGNOLIA SAINT MARY	TRUE GREEN ELM	INCENSE CEDAR	CHINESE PISTACHE			
DEARBORN AV	Neighborhood 14	CHINESE ELM				TRUE GREEN ELM	BOTTLE TREE	CHINESE PISTACHE			
DEEBLE ST	Neighborhood 10	SOUTHERN LIVE OAK				HOLLY OAK	BOTTLE TREE	INCENSE CEDAR			
DOLORES AV	District 2	COAST LIVE OAK	REDSPIRE PEAR	CHITALPA	MAGNOLIA SAINT MARY				COAST LIVE OAK	CHINESE FLAME TREE	FERN PINE
DOROTHY AV	Neighborhood 5	CHINESE ELM				DRAKE ELM	TULIP TREE	NICHOLS WILLOW LEAFED PEPPERMINT			
DOROTHY AV	Neighborhood 6	INDIAN LAUREL FIG				DRAKE ELM	TULIP TREE	NICHOLS WILLOW LEAFED PEPPERMINT			
DUANE WY	Neighborhood 10	LEMON BOTTLEBRUSH	ARISTOCRAT PEAR	CRAPE MYRTLE	HONG KONG ORCHID TREE	CRAPE MYRTLE	AFRICAN SUMAC	PURPLE ORCHID TREE			
DUANE WY	Neighborhood 6	CARROTWOOD				CRAPE MYRTLE	AFRICAN SUMAC	ARISTOCRAT PEAR			
DUANE WY	Neighborhood 7	CRAPE MYRTLE				CRAPE MYRTLE	AFRICAN SUMAC	ARISTOCRAT PEAR			
DUDLEXT AV	Neighborhood 6	CRAPE MYRTLE				CRAPE MYRTLE	LAVENDER TRUMPET TREE	AFGHAN PINE			
DUNCAN WY	Neighborhood 4	VICTORIAN BOX				AFGHAN PINE	DRAKE ELM	JAPANESE PAGODA TREE			
ELIZABETH AV	Neighborhood 10	ORNAMENTAL PEAR	ARISTOCRAT PEAR	CRAPE MYRTLE	CHITALPA	ARISTOCRAT PEAR	HOLLY OAK	LAVENDER TRUMPET TREE			
ELIZABETH AV	Neighborhood 14	CRAPE MYRTLE				CRAPE MYRTLE	HOLLY OAK	LAVENDER TRUMPET TREE			
ELIZABETH AV	Neighborhood 9	CRAPE MYRTLE	CRAPE MYRTLE	ARISTOCRAT PEAR	CHITALPA	CRAPE MYRTLE	HOLLY OAK	LAVENDER TRUMPET TREE			
EVERGREEN AV	Neighborhood 10	JACARANDA				PURPLE ORCHID TREE	HOLLY OAK	CHINESE TALLOW TREE			
EVERGREEN AV	Neighborhood 14	CAJAPUT TREE				MAIDENHAIR TREE	HOLLY OAK	CHINESE TALLOW TREE			
FIRESTONE BL	Corridor B	BRISBANE BOX	CHITALPA	CRAPE MYRTLE	WATER CUM	RED IRONBARK	AUSTRALIAN WILLOW	AFGHAN PINE	BRISBANE BOX	SOUTHERN LIVE OAK	CANARY ISLAND PINE
FIRESTONE BL	District 6	BRISBANE BOX	CHANTICLEER PEAR	CHINESE FRINGE TREE	CRAPE MYRTLE	AUSTRALIAN WILLOW	AFGHAN PINE	BOTTLE TREE	BRISBANE BOX	DRAKE ELM	INCENSE CEDAR
FIRESTONE BL	Neighborhood 10	LONDON PLANE				MAGNOLIA MAJESTIC BEAUTY	AFGHAN PINE	MINDANAO CUM			
FIRESTONE BL	Neighborhood 13	CRAPE MYRTLE	CRAPE MYRTLE	MAGNOLIA SAINT MARY	CHANTICLEER PEAR	MAGNOLIA MAJESTIC BEAUTY	AFGHAN PINE	MINDANAO CUM			
FIRESTONE BL	Neighborhood 14	JACARANDA				MAGNOLIA MAJESTIC BEAUTY	AFGHAN PINE	MINDANAO CUM			
FIRESTONE BL	Neighborhood 6	INDIAN LAUREL FIG				MAGNOLIA MAJESTIC BEAUTY	AFGHAN PINE	MINDANAO CUM			
FIRESTONE PLZ	Neighborhood 12	SOUTHERN MAGNOLIA				MAGNOLIA SAMUEL SOMMER	BOTTLE TREE	HOLLY OAK			
FLORENCE AV	District 8	CARROTWOOD				MINDANAO CUM	PINK TRUMPET TREE	HOLLY OAK			
FLORENCE AV	Neighborhood 1	CRAPE MYRTLE				CRAPE MYRTLE	LAVENDER TRUMPET TREE	PURPLE ORCHID TREE			
FRONTAGE RD. E	District 7	MEXICAN FAN PALM				INCENSE CEDAR	BOTTLE TREE	CHINESE TALLOW TREE			

City of South Gate

Street Tree Planting Plan

November 2007

STREET	GENERAL PLAN AREA	CURRENT PRIMARY SPECIES	2-3FT PARKWAYS (GROWING SPACES)			5FT PARKWAYS (GROWING SPACES)			8FT PARKWAYS (GROWING SPACES)		
			RECOMMENDATION 1	RECOMMENDATION 2	RECOMMENDATION 3	RECOMMENDATION 1	RECOMMENDATION 2	RECOMMENDATION 3	RECOMMENDATION 1	RECOMMENDATION 2	RECOMMENDATION 3
GARDEN VIEW AV	Neighborhood 10	JACARANDA				AFGHAN PINE	TRUE GREEN ELM	JAPANESE PAGODA TREE			
GARDEN VIEW AV	Neighborhood 14	JACARANDA				TRUE GREEN ELM	MINDANAO GUM	JAPANESE PAGODA TREE			
GARDENDALE ST	District 8	SOUTHERN MAGNOLIA	REDSPIRE PEAR	HONG KONG ORCHID	GRAPE MYRTLE	MAGNOLIA MAJESTIC BEAUTY	PURPLE ORCHID TREE	DRAKE ELM			
GARDENDALE ST	Neighborhood 1	GRAPE MYRTLE				GRAPE MYRTLE	HOLLY OAK	MINDANAO GUM			
GARFIELD AV	District 6	MEXICAN FAN PALM	CHITALPA	CHANTICLEER PEAR	GRAPE MYRTLE	INCENSE CEDAR	HOLLY OAK	TULIP TREE	BRISBANE BOX	SOUTHERN LIVE OAK	SOUTHERN MAGNOLIA
GARFIELD AV	District 7	CARROTWOOD	CHITALPA	CHANTICLEER PEAR	GRAPE MYRTLE	INCENSE CEDAR	HOLLY OAK	TULIP TREE	BRISBANE BOX	SOUTHERN LIVE OAK	SOUTHERN MAGNOLIA
GARFIELD AV	District 8	VACANTSITE	CHITALPA	CHANTICLEER PEAR	GRAPE MYRTLE	INCENSE CEDAR	HOLLY OAK	TULIP TREE	BRISBANE BOX	SOUTHERN LIVE OAK	SOUTHERN MAGNOLIA
GARFIELD AV	District 9	BRISBANE BOX	CHITALPA	CHANTICLEER PEAR	GRAPE MYRTLE	INCENSE CEDAR	HOLLY OAK	TULIP TREE	BRISBANE BOX	SOUTHERN LIVE OAK	SOUTHERN MAGNOLIA
GARFIELD AV	Neighborhood 1	BRISBANE BOX	MAGNOLIA SAINT MARY	DANCER PEAR	CHITALPA	MAGNOLIA MAJESTIC BEAUTY	BOTTLE TREE	TULIP TREE	BRISBANE BOX	TRUE GREEN ELM	LONDON PLANE
GARFIELD AV	Neighborhood 2	CARROTWOOD				MAGNOLIA MAJESTIC BEAUTY	BOTTLE TREE	TULIP TREE			
GARFIELD PL	District 8	CARROTWOOD	GRAPE MYRTLE	HONG KONG ORCHID	WATER GUM						
GLADYST	Neighborhood 2	JACARANDA				MINDANAO GUM	LAVENDER TRUMPET TREE	DRAKE ELM			
GLENWOOD PL	Neighborhood 10	PURPLE ORCHID TREE				PURPLE ORCHID TREE	MAGNOLIA SAMUEL SOMMER	DRAKE ELM			
GLENWOOD PL	Neighborhood 12	PURPLE ORCHID TREE	HONG KONG ORCHID TREE	CHITALPA	DANCER PEAR	PURPLE ORCHID TREE	MAGNOLIA SAMUEL SOMMER	DRAKE ELM			
HARDING AV	District 8	HOLLY OAK				HOLLY OAK	MAGNOLIA MAJESTIC BEAUTY	CHINESE PISTACHE			
HARDING AV	Neighborhood 1	GRAPE MYRTLE				GRAPE MYRTLE	PURPLE ORCHID TREE	AFGHAN PINE			
HILDRETH AV	Neighborhood 5	GRAPE MYRTLE				GRAPE MYRTLE	LAVENDER TRUMPET TREE	PURPLE-LEAF PLUM			
HILDRETH AV	Neighborhood 6	INDIAN LAUREL FIG				LAVENDER TRUMPET TREE	PURPLE ORCHID TREE	HOLLY OAK			
HOWERY ST	Neighborhood 1	CHINESE PISTACHE	GRAPE MYRTLE	CHITALPA	DANCER PEAR	CHINESE PISTACHE	GOLDENRAIN TREE	MAGNOLIA SAMUEL SOMMER	CAMPHOR TREE	CHINESE FLAME TREE	SOUTHERN MAGNOLIA
HUNT AV	Neighborhood 5	JACARANDA				HOLLY OAK	TRUE GREEN ELM	JAPANESE PAGODA TREE			
HUNTAV	Neighborhood 6	JACARANDA	GRAPE MYRTLE	ARISTOCRAT PEAR	HONG KONG ORCHID TREE	RED IRONBARK	TRUE GREEN ELM	JAPANESE PAGODA TREE			
IDAHO AV	District 8	LONDON PLANE							LONDON PLANE TREE	SAWLEAF ZELKOVA	SOUTHERN MAGNOLIA
IDAHO AV	Neighborhood 1	ARIZONA ASH				CHINESE TALLOW TREE	CHINESE PISTACHE	AUSTRALIAN WILLOW			
ILLINOIS AV	Neighborhood 10	JACARANDA				BOTTLE TREE	MAGNOLIA SAMUEL SOMMER	TULIP TREE			
ILLINOIS AV	Neighborhood 12	ORNAMENTAL PEAR				ARISTOCRAT PEAR	MAGNOLIA SAMUEL SOMMER	TULIP TREE			
IMPERIAL HWY	District 8	CARROTWOOD	CHINESE FRINCE TREE	CHITALPA	REDSPIRE PEAR	BOTTLE TREE	MAGNOLIA MAJESTIC BEAUTY	PINK TRUMPET TREE	BRISBANE BOX	CANARY ISLAND PINE	ROUND-LEAF SWEETGUM
IMPERIAL HWY	Neighborhood 2	CARROTWOOD				MAGNOLIA MAJESTIC BEAUTY	RED IRONBARK	HOLLY OAK	SOUTHERN MAGNOLIA	RED IRONBARK	SOUTHERN LIVE OAK
INDEPENDENCE AV	District 4	CORK OAK				HOLLY OAK	MINDANAO GUM	INCENSE CEDAR			
INDEPENDENCE AV	Neighborhood 14	CAJUPUT TREE	MAGNOLIA SAINT MARY	WATER GUM	CHANTICLEER PEAR	MAGNOLIA SAMUEL SOMMER	BOTTLE TREE	INCENSE CEDAR			
INDEPENDENCE AV	Neighborhood 15	CAROB				MAGNOLIA SAMUEL SOMMER	BOTTLE TREE	INCENSE CEDAR			
INDIANA AV	Neighborhood 10	INDIAN LAUREL FIG				GRAPE MYRTLE	HOLLY OAK	INCENSE CEDAR			
INDIANA AV	Neighborhood 12	GRAPE MYRTLE				GRAPE MYRTLE	HOLLY OAK	BOTTLE TREE			
INDUSTRIAL AV	District 8	GRAPE MYRTLE	GRAPE MYRTLE	CHANTICLEER PEAR	WATER GUM						
INDUSTRIAL AV	Neighborhood 1	GRAPE MYRTLE	GRAPE MYRTLE	CHANTICLEER PEAR	WATER GUM	GRAPE MYRTLE	LAVENDER TRUMPET TREE	TULIP TREE			
IOWA AV	Neighborhood 10	GRAPE MYRTLE				GRAPE MYRTLE	HOLLY OAK	AFGHAN PINE			
IOWAAV	Neighborhood 12	CAMPHOR TREE				HOLLY OAK	NICHOL'S WILLOW LEAFED PEPPERMINT	GRAPE MYRTLE			
JACKSON AV	Neighborhood 5	CHINESE ELM				TRUE GREEN ELM	PURPLE ORCHID TREE	AUSTRALIAN WILLOW			
JEFFERSON AV	Neighborhood 1	SOUTHERN MAGNOLIA				MAGNOLIA SAMUEL SOMMER	BOTTLE TREE	GRAPE MYRTLE			

City of South Gate

Street Tree Planting Plan

November 2007

STREET	GENERAL PLAN AREA	CURRENT PRIMARY SPECIES	2-3FT PARKWAYS (GROWING SPACES)			5FT PARKWAYS (GROWING SPACES)			8FT PARKWAYS (GROWING SPACES)		
			RECOMMENDATION 1	RECOMMENDATION 2	RECOMMENDATION 3	RECOMMENDATION 1	RECOMMENDATION 2	RECOMMENDATION 3	RECOMMENDATION 1	RECOMMENDATION 2	RECOMMENDATION 3
KANSAS AV	Neighborhood 10	ORNAMENTAL PEAR				ARISTOCRAT PEAR	DRAKE ELM	RED IRONBARK			
KANSAS AV	Neighborhood 12	INDIAN LAUREL FIG				ARISTOCRAT PEAR	DRAKE ELM	AFGHAN PINE			
KARMONT AV	District 6	QUEEN PALM				HOLLY OAK	RED IRONBARK	MAGNOLIA MAJESTIC BEAUTY			
KARMONT AV	Neighborhood 2	CRAPE MYRTLE				ARISTOCRAT PEAR	AFGHAN PINE	MINDANAO GUM			
KATELLA RD	Neighborhood 3	CAROLINA LAUREL CHERRY				PURPLE ORCHID TREE	LAVENDER TRUMPET TREE	CHINESE PISTACHE			
KAUFFMAN AV	Neighborhood 5	FERN PINE				BOTTLE TREE	NICHOLS WILLOW-LEAFED PEPPERMINT	AFRICAN SUMAC			
KAUFFMAN AV	Neighborhood 6	INDIAN LAUREL FIG				HOLLY OAK	AUSTRALIAN WILLOW	AFRICAN SUMAC			
LAUREL PL	Neighborhood 13	CRAPE MYRTLE	CRAPE MYRTLE	CHITALPA	ARISTOCRAT PEAR	TRUE GREEN ELM	HOLLY OAK	CRAPE MYRTLE			
LAUREL PL	Neighborhood 14	CARROTWOOD				TRUE GREEN ELM	HOLLY OAK	CRAPE MYRTLE			
LEDGEWOOD RD	Neighborhood 3	CHINESE PISTACHE				CHINESE PISTACHE	GOLDENRAIN TREE	TULIP TREE			
LEEDS ST	Neighborhood 2	LEMON BOTTLEBRUSH				AFRICAN SUMAC	AUSTRALIAN WILLOW	GOLDENRAIN TREE			
LIBERTY BL	Neighborhood 14	CAROB				HOLLY OAK	TRUE GREEN ELM	AFGHAN PINE			
LIBERTY BL	Neighborhood 15	CAROB				BOTTLE TREE	TRUE GREEN ELM	AFGHAN PINE			
LILLIAN LN	Neighborhood 1	CHINESE ELM							FRONTIER ELM	CAMPHOR TREE	CHINESE HACKBERRY
LINCOLN AV	District 8	COAST LIVE OAK				HOLLY OAK	RED IRONBARK	MAGNOLIA MAJESTIC BEAUTY	COAST LIVE OAK	BRISBANE BOX	SAWLEAF ZELKOVA
LINCOLN AV	Neighborhood 1	CRAPE MYRTLE				CRAPE MYRTLE	DRAKE ELM	MINDANAO GUM			
LONG BEACH BL	Corridor A	ORNAMENTAL PEAR	ARISTOCRAT PEAR	CHINESE FRINGE TREE	HONG KONG ORCHID	GOLDENRAIN TREE	AFRICAN SUMAC	PINK TRUMPET TREE	CANARY ISLAND PINE	COAST LIVE OAK	ROUND-LEAFED SWEETGUM
LONG BEACH BL	Neighborhood 10	CHINESE PISTACHE	MAGNOLIA SAINT MARY	ARISTOCRAT PEAR	CRAPE MYRTLE	CHINESE PISTACHE	MAGNOLIA SAMUEL SOMMER	BOTTLE TREE	SOUTHERN MAGNOLIA	BRISBANE BOX	LONDON PLANE
LONG BEACH BL	Neighborhood 11	CARROTWOOD	MAGNOLIA SAINT MARY	ARISTOCRAT PEAR	CRAPE MYRTLE	CHINESE PISTACHE	MAGNOLIA SAMUEL SOMMER	BOTTLE TREE	SOUTHERN MAGNOLIA	BRISBANE BOX	LONDON PLANE
LONG BEACH BL	Neighborhood 12	QUEEN PALM				CHINESE PISTACHE	MAGNOLIA SAMUEL SOMMER	ARISTOCRAT PEAR			
LONG BEACH BL	Neighborhood 13	BRAZILIAN PEPPER				CHINESE PISTACHE	MAGNOLIA SAMUEL SOMMER	ARISTOCRAT PEAR			
LONG BEACH BL	Neighborhood 14	ORNAMENTAL PEAR	MAGNOLIA SAINT MARY	ARISTOCRAT PEAR	CRAPE MYRTLE	CHINESE PISTACHE	MAGNOLIA SAMUEL SOMMER	ARISTOCRAT PEAR			
LUXOR ST	District 6	FERN PINE							FERN PINE	CANARY ISLAND PINE	FRONTIER ELM
MADGE AV	Neighborhood 2	CAROLINA LAUREL CHERRY				TULIP TREE	BOTTLE TREE	RED IRONBARK			
MADISON AV	Neighborhood 10	SOUTHERN MAGNOLIA				MAGNOLIA SAMUEL SOMMER	BOTTLE TREE	MAIDENHAIR TREE			
MADISON AV	Neighborhood 14	SOUTHERN MAGNOLIA				MAGNOLIA SAMUEL SOMMER	BOTTLE TREE	MAIDENHAIR TREE			
MADRID PL	Neighborhood 14	PURPLE ORCHID TREE	HONG KONG ORCHID TREE	CRAPE MYRTLE	CHITALPA						
MAIN ST	District 8	CAROLINA LAUREL CHERRY				MAIDENHAIR TREE	NICHOLS WILLOW-LEAFED PEPPERMINT	TRUE GREEN ELM			
MAIN ST	Neighborhood 1	CRAPE MYRTLE				CRAPE MYRTLE	GOLDENRAIN TREE	LAVENDER TRUMPET TREE	CHINESE FLAME TREE	CAMPHOR TREE	BRISBANE BOX
MALLISON AV	Neighborhood 7	CHINESE HACKBERRY				TRUE GREEN ELM	MAGNOLIA SAMUEL SOMMER	CHINESE TALLOW TREE			
MALLISON AV	Neighborhood 8	CRAPE MYRTLE	CRAPE MYRTLE	MAGNOLIA SAINT MARY	DANCER PEAR	TRUE GREEN ELM	MAGNOLIA SAMUEL SOMMER	CHINESE TALLOW TREE			
MAY CT	Neighborhood 6	SOUTHERN MAGNOLIA	MAGNOLIA SAINT MARY	DANCER PEAR	CHITALPA	MAGNOLIA MAJESTIC BEAUTY	BOTTLE TREE	INCENSE CEDAR			
MCCALLUM AV	Neighborhood 4	LONDON PLANE				TULIP TREE	MAGNOLIA SAMUEL SOMMER	DRAKE ELM			
MCCALLUM AV	Neighborhood 7	SOUTHERN MAGNOLIA				MAGNOLIA SAMUEL SOMMER	TULIP TREE	DRAKE ELM			
MCKINLEY AV	Neighborhood 1	CRAPE MYRTLE				CRAPE MYRTLE	GOLDENRAIN TREE	LAVENDER TRUMPET TREE			
MCNERNEY AV	Neighborhood 7	SOUTHERN MAGNOLIA	MAGNOLIA SAINT MARY	CRAPE MYRTLE	WATERGLUM	MAGNOLIA SAMUEL SOMMER	RED IRONBARK	BOTTLE TREE			
MCNERNEY AV	Neighborhood 8	SOUTHERN MAGNOLIA				MAGNOLIA SAMUEL SOMMER	HOLLY OAK	BOTTLE TREE			
MEADOW RD	Neighborhood 2	CRAPE MYRTLE				CRAPE MYRTLE	LAVENDER TRUMPET TREE	HOLLY OAK			
MICHIGAN AV	Neighborhood 5	ARIZONA ASH				CHINESE PISTACHE	AUSTRALIAN WILLOW	CHINESE TALLOW TREE			
MICHIGAN AV	Neighborhood 8	ARIZONA ASH				CHINESE PISTACHE	AUSTRALIAN WILLOW	CHINESE TALLOW TREE			

City of South Gate

Street Tree Planting Plan

November 2007

STREET	GENERAL PLAN AREA	2-3FT PARKWAYS (GROWING SPACES)			5FT PARKWAYS (GROWING SPACES)			8FT PARKWAYS (GROWING SPACES)			
		CURRENT PRIMARY SPECIES	RECOMMENDATION 1	RECOMMENDATION 2	RECOMMENDATION 3	RECOMMENDATION 1	RECOMMENDATION 2	RECOMMENDATION 3	RECOMMENDATION 1	RECOMMENDATION 2	RECOMMENDATION 3
MICHIGAN AV	Neighborhood 9	ARIZONA ASH	CRAPE MYRTLE	DANCER PEAR	WATER GUM	CHINESE PISTACHE	AUSTRALIAN WILLOW	CHINESE TALLOW TREE			
MILLER WY	District 7	MEXICAN FAN PALM	ARISTOCRAT PEAR	CHITALPA	MAGNOLIA SAINT MARY						
MINNESOTA AV	Neighborhood 9	CRAPE MYRTLE	CRAPE MYRTLE	HONG KONG ORCHID TREE	CHITALPA						
MISSOURI AV	Neighborhood 10	LEMON BOTTLEBRUSH	CHANTICLEER PEAR	CHITALPA	WATER GUM	RED IRONBARK	HOLLY OAK	CRAPE MYRTLE			
MISSOURI AV	Neighborhood 12	CRAPE MYRTLE	CRAPE MYRTLE			CRAPE MYRTLE	HOLLY OAK	CRAPE MYRTLE			
MISSOURI AV	Neighborhood 6	VICTORIAN BOX	CHANTICLEER PEAR	CHITALPA	WATER GUM						
MISSOURI AV	Neighborhood 7	CRAPE MYRTLE				CRAPE MYRTLE	CHINESE PISTACHE	HOLLY OAK			
MONROE AV	Neighborhood 1	CRAPE MYRTLE				CRAPE MYRTLE	MAGNOLIA SAMUEL SOMMER	BOTTLE TREE			
MONTARA AV	Neighborhood 11	FERN PINE	MAGNOLIA SAINT MARY	HONG KONG ORCHID TREE	DANCER PEAR	AFGHAN PINE	INCENSE CEDAR	CHINESE PISTACHE			
MOUNTAIN VIEW AV	Neighborhood 14	CAJEPUT TREE				CHINESE PISTACHE	JAPANESE PAGODA TREE	NICHOLS WILLOW LEAFED PEPPERMINT			
NEBRASKA AV	Neighborhood 12	AUSTRALIAN WILLOW				AUSTRALIAN WILLOW	AFRICAN SUMAC	BOTTLE TREE			
NEVADA AV	District 8	SOUTHERN LIVE OAK							SOUTHERN LIVE OAK	FERN PINE	LEMON-SCENTED GUM
NEVADA AV	Neighborhood 7	ARIZONA ASH				MAIDENHAIR TREE	TULIP TREE	PURPLE ORCHID TREE			
OHIO AV	Neighborhood 10	CRAPE MYRTLE				CRAPE MYRTLE	AFGHAN PINE	ARISTOCRAT PEAR			
OHIO AV	Neighborhood 12	CRAPE MYRTLE				CRAPE MYRTLE	TULIP TREE	ARISTOCRAT PEAR			
OKLAHOMA AV	District 8	SOUTHERN MAGNOLIA				MAGNOLIA MAJESTIC BEAUTY	RED IRONBARK	HOLLY OAK			
OKLAHOMA AV	Neighborhood 1	CRAPE MYRTLE				CRAPE MYRTLE	MAGNOLIA SAMUEL SOMMER	CHINESE TALLOW TREE			
ORANGE AV	Neighborhood 5	CRAPE MYRTLE				CRAPE MYRTLE	HOLLY OAK	CHINESE PARASOL TREE			
ORCHARD PL	Neighborhood 13	SOUTHERN LIVE OAK				HOLLY OAK	NICHOLS WILLOW LEAFED PEPPERMINT	JAPANESE PAGODA TREE			
ORCHARD PL	Neighborhood 14	SOUTHERN LIVE OAK				HOLLY OAK	NICHOLS WILLOW LEAFED PEPPERMINT	JAPANESE PAGODA TREE			
OTIS ST	District 4	CORK OAK	CHITALPA	CHINESE FRINGE TREE	ARISTOCRAT PEAR						
OTIS ST	Neighborhood 15	CORK OAK				HOLLY OAK	TRUE GREEN ELM	TULIP TREE			
OTIS ST	Neighborhood 7	LEMON BOTTLEBRUSH				HOLLY OAK	TRUE GREEN ELM	TULIP TREE			
OTIS ST	Neighborhood 8	LONDON PLANE				HOLLY OAK	TRUE GREEN ELM	TULIP TREE			
PALM PL	Neighborhood 14	QUEEN PALM	REDSPIRE PEAR	MAGNOLIA SAINT MARY	HONG KONG ORCHID TREE	MAGNOLIA MAJESTIC BEAUTY	PURPLE ORCHID TREE	BOTTLE TREE			
PARAMOUNT BL	Corridor F	CRAPE MYRTLE	CRAPE MYRTLE	CHINESE FRINGE TREE	HONG KONG ORCHID	MAIDENHAIR TREE	RED IRONBARK	GOLDENRAIN TREE	CANARY ISLAND PINE	SAWLEAF ZELKOVA	FERN PINE
PARAMOUNT BL	Neighborhood 1	QUEEN PALM				MINDANAO GUM	MAGNOLIA MAJESTIC BEAUTY	LAVENDER TRUMPET TREE			
PENDELTON AV	Neighborhood 3	SOUTHERN MAGNOLIA				MAGNOLIA SAMUEL SOMMER	BOTTLE TREE	CHINESE PISTACHE			
PENNSYLVANIA AV	District 8	SOUTHERN MAGNOLIA				MAGNOLIA MAJESTIC BEAUTY	HOLLY OAK	RED IRONBARK			
PENNSYLVANIA AV	Neighborhood 1	CRAPE MYRTLE				CRAPE MYRTLE	CHINESE PISTACHE	LAVENDER TRUMPET TREE			
PESCADERO AV	Neighborhood 11	FERN PINE				AFGHAN PINE	INCENSE CEDAR	BOTTLE TREE			
PINE PL	Neighborhood 14	CRAPE MYRTLE				CRAPE MYRTLE	LAVENDER TRUMPET TREE	PURPLE ORCHID TREE			
PINEHURST AV	Neighborhood 5	CAMPHOR TREE				HOLLY OAK	CRAPE MYRTLE	HOLLY OAK			
POPLAR PL	Neighborhood 14	AMERICAN SWEETGUM				TULIP TREE	MINDANAO GUM	MAIDENHAIR TREE			
POST ST	Neighborhood 14	CHINESE ELM	CRAPE MYRTLE	REDSPIRE PEAR	CHITALPA	DRAKE ELM	HOLLY OAK	NICHOLS WILLOW LEAFED PEPPERMINT			
RENOA AV	Neighborhood 2	BLACK LOCUST				JAPANESE PAGODA TREE	PURPLE ORCHID TREE	BOTTLE TREE			
RICHLEE AV	Neighborhood 2	BRONZE LOQUAT				HOLLY OAK	CHINESE TALLOW TREE	LAVENDER TRUMPET TREE			

City of South Gate

Street Tree Planting Plan

November 2007

STREET	GENERAL PLAN AREA	CURRENT PRIMARY SPECIES	2-3FT PARKWAYS (GROWING SPACES)			5FT PARKWAYS (GROWING SPACES)			8FT PARKWAYS (GROWING SPACES)		
			RECOMMENDATION 1	RECOMMENDATION 2	RECOMMENDATION 3	RECOMMENDATION 1	RECOMMENDATION 2	RECOMMENDATION 3	RECOMMENDATION 1	RECOMMENDATION 2	RECOMMENDATION 3
ROOSEVELT AV	District 8	CAROB				MAGNOLIA MAJESTIC BEAUTY	HOLLY OAK	RED IRONBARK			
ROOSEVELT AV	Neighborhood 1	CRAPE MYRTLE				CRAPE MYRTLE	DRAKE ELM	AUSTRALIAN WILLOW			
ROSEWOOD AV	Neighborhood 5	CRAPE MYRTLE				CRAPE MYRTLE	AFGHAN PINE	CHINESE TALLOW TREE			
RLCHTI RD	District 8	MEXICAN FAN PALM							SOUTHERN LIVE OAK	FERN PINE	LEMON-SCENTED GUM
SAINT JAMES AV	Neighborhood 3	ARIZONA ASH				MAGNOLIA SAMUEL SOMMER	CHINESE PARASOL TREE	CRAPE MYRTLE	SOUTHERN MAGNOLIA	SAW-TOOTH ZELKOVA	TIPL
SALT LAKE AV	Neighborhood 4	WEeping FIG				AFRICAN SUMAC	AUSTRALIAN WILLOW	CHINESE PISTACHE			
SAN ANSELMO AV	Neighborhood 11	INDIAN LAUREL FIG				AUSTRALIAN WILLOW	CHINESE PARASOL TREE	INCENSE CEDAR			
SAN ANTONIO AV	Neighborhood 15	CARROTWOOD				GOLDENRAIN TREE	AFGHAN PINE	HOLLY OAK			
SAN ANTONIO AV	Neighborhood 7	JACARANDA				TULIP TREE	GOLDENRAIN TREE	NICHOLS WILLOW LEAFED PEPPERMINT			
SAN ANTONIO AV	Neighborhood 8	JACARANDA	CHITALPA	CRAPE MYRTLE	ARISTOCRAT PEAR	MINDANAO GUM	GOLDENRAIN TREE	INCENSE CEDAR			
SAN CARLOS AV	Neighborhood 15	CRAPE MYRTLE				CRAPE MYRTLE	TULIP TREE	CHINESE TALLOW TREE			
SAN CARLOS AV	Neighborhood 7	CAMPHOR TREE				RED IRONBARK	CHINESE TALLOW TREE	MAGNOLIA SAMUEL SOMMER			
SAN CARLOS AV	Neighborhood 8	CAMPHOR TREE	CRAPE MYRTLE	HONG KONG ORCHID TREE	MAGNOLIA SAINT MARY	BOTTLE TREE	CHINESE TALLOW TREE	MAGNOLIA SAMUEL SOMMER			
SAN GABRIEL AV	Neighborhood 15	AMERICAN SWEETGUM				TULIP TREE	DRAKE ELM	BOTTLE TREE			
SAN GABRIEL AV	Neighborhood 7	CHINESE ELM				TULIP TREE	DRAKE ELM	BOTTLE TREE			
SAN GABRIEL AV	Neighborhood 8	EUROPEAN HACKBERRY				TULIP TREE	DRAKE ELM	BOTTLE TREE			
SAN JOSE AV	Neighborhood 11	LEMON BOTTLEBRUSH				AUSTRALIAN WILLOW	AFRICAN SUMAC	TRUE GREEN ELM			
SAN JUAN AV	Neighborhood 15	CRAPE MYRTLE				CRAPE MYRTLE	TRUE GREEN ELM	PURPLE ORCHID TREE			
SAN JUAN AV	Neighborhood 7	CARROTWOOD				TRUE GREEN ELM	PURPLE ORCHID TREE	CHINESE PISTACHE			
SAN JUAN AV	Neighborhood 8	PURPLE ORCHID TREE	HONG KONG ORCHID TREE	CHITALPA	DANCER PEAR	TRUE GREEN ELM	PURPLE ORCHID TREE	CHINESE PISTACHE			
SAN LUIS AV	Neighborhood 15	CHINESE ELM				TRUE GREEN ELM	AFRICAN SUMAC	AFGHAN PINE			
SAN LUIS AV	Neighborhood 7	INDIAN LAUREL FIG	MAGNOLIA SAINT MARY	CHANTICLEER PEAR	WATERGUM	TRUE GREEN ELM	AFRICAN SUMAC	AFGHAN PINE			
SAN LUIS AV	Neighborhood 8	FERN PINE				TRUE GREEN ELM	BOTTLE TREE	AFGHAN PINE			
SAN MIGUEL AV	Neighborhood 15	CAROLINA LAUREL CHERRY				RED IRONBARK	TRUE GREEN ELM	CHINESE TALLOW TREE			
SAN MIGUEL AV	Neighborhood 7	LEMON BOTTLEBRUSH	CHITALPA	ARISTOCRAT PEAR	MAGNOLIA SAINT MARY	HOLLY OAK	TRUE GREEN ELM	CHINESE TALLOW TREE			
SAN MIGUEL AV	Neighborhood 8	JACARANDA				CHINESE PISTACHE	TRUE GREEN ELM	CHINESE TALLOW TREE			
SAN VINCENTE AV	Neighborhood 15	CHINESE ELM				TRUE GREEN ELM	ARISTOCRAT PEAR	MAIDENHAIR TREE			
SAN VINCENTE AV	Neighborhood 7	ORNAMENTAL PEAR				TRUE GREEN ELM	ARISTOCRAT PEAR	NICHOLS WILLOW LEAFED PEPPERMINT			
SAN VINCENTE AV	Neighborhood 8	CHINESE ELM				TRUE GREEN ELM	ARISTOCRAT PEAR	NICHOLS WILLOW LEAFED PEPPERMINT			
SANTA ANA ST	Neighborhood 14	CRAPE MYRTLE	CRAPE MYRTLE	MAGNOLIA SAINT MARY	DANCER PEAR	CRAPE MYRTLE	TRUE GREEN ELM	MAGNOLIA SAMUEL SOMMER			
SANTA ANA ST	Neighborhood 15	CHINESE ELM				TRUE GREEN ELM	MAGNOLIA SAMUEL SOMMER	AFGHAN PINE			
SANTA FE AV	Neighborhood 12	SOUTHERN MAGNOLIA				MAGNOLIA SAMUEL SOMMER	BOTTLE TREE	MAIDENHAIR TREE			
SANTA FE AV	Neighborhood 13	QUEEN PALM				MAGNOLIA SAMUEL SOMMER	BOTTLE TREE	MAIDENHAIR TREE			
SEMINOLE AV	Neighborhood 11	INDIAN LAUREL FIG				MAGNOLIA SAMUEL SOMMER	HOLLY OAK	GOLDENRAIN TREE	SOUTHERN MAGNOLIA	CHINESE FLAME TREE	BRISBANE BOX
SEMINOLE AV	Neighborhood 9	INDIAN LAUREL FIG	ARISTOCRAT PEAR	MAGNOLIA SAINT MARY	CHITALPA	MAGNOLIA SAMUEL SOMMER	MINDANAO GUM	GOLDENRAIN TREE			
SEQUOIA DR	District 2	VACANTSITE				INCENSE CEDAR	RED IRONBARK	DRAKE ELM			
SEQUOIA DR	Neighborhood 11	LEMON BOTTLEBRUSH				CRAPE MYRTLE	MINDANAO GUM	CHINESE PISTACHE			
SEQUOIA DR	Neighborhood 9	CRAPE MYRTLE				CRAPE MYRTLE	AFGHAN PINE	CHINESE PISTACHE			
SESSLER ST	District 7	STUMP	WATER GUM	HONG KONG ORCHID	MAGNOLIA SAINT MARY						
SESSLER ST	District 8	MEXICAN FAN PALM				INCENSE CEDAR	MINDANAO GUM	PURPLE ORCHID TREE			

City of South Gate

Street Tree Planting Plan

November 2007

STREET	GENERAL PLAN AREA	2-3FT PARKWAYS (GROWING SPACES)			5FT PARKWAYS (GROWING SPACES)			8FT PARKWAYS (GROWING SPACES)			
		CURRENT PRIMARY SPECIES	RECOMMENDATION 1	RECOMMENDATION 2	RECOMMENDATION 3	RECOMMENDATION 1	RECOMMENDATION 2	RECOMMENDATION 3	RECOMMENDATION 1	RECOMMENDATION 2	RECOMMENDATION 3
SEVILLE AV	Neighborhood 14	CRAPE MYRTLE	CRAPE MYRTLE	ARISTOCRAT PEAR	CHITALPA	HOLLY OAK	BOTTLE TREE	CHINESE TALLOW TREE			
SOUTH GATE AV	Neighborhood 10	SOUTHERN LIVE OAK				HOLLY OAK	INCENSE CEDAR	PURPLE ORCHID TREE			
SOUTH GATE AV	Neighborhood 14	CAMPBOR TREE				HOLLY OAK	PURPLE ORCHID TREE	CRYPTOCARYA RUBRA			
SOUTHERN AV	District 1	SOUTHERN MAGNOLIA				MAGNOLIA MAJESTIC BEAUTY	PURPLE ORCHID TREE	AFGHAN PINE			
SOUTHERN AV	Neighborhood 10	SOUTHERN MAGNOLIA	MAGNOLIA SAINT MARY	CRAPE MYRTLE	CHITALPA	MAGNOLIA SAMUEL SOMMER	DRAKE ELM	AFGHAN PINE			
SOUTHERN AV	Neighborhood 12	SOUTHERN MAGNOLIA				MAGNOLIA SAMUEL SOMMER	DRAKE ELM	AFGHAN PINE			
SOUTHERN AV	Neighborhood 4	CAROB							BRONZE LOQUAT	DRAKE ELM	CANARY ISLAND PINE
SOUTHERN AV	Neighborhood 6	SOUTHERN MAGNOLIA				MAGNOLIA SAMUEL SOMMER	DRAKE ELM	AFGHAN PINE			
SOUTHERN AV	Neighborhood 7	SOUTHERN MAGNOLIA				MAGNOLIA SAMUEL SOMMER	DRAKE ELM	AFGHAN PINE			
SOUTHERN LN	Neighborhood 6	SOUTHERN MAGNOLIA				MAGNOLIA SAMUEL SOMMER	DRAKE ELM	AFGHAN PINE			
STANFORD AV	District 2	COAST LIVE OAK				AUSTRALIAN WILLOW	RED IRONBARK	DRAKE ELM	COAST LIVE OAK	SAWLEAF ZELKOVA	LEMON-SCENTED GUM
STANFORD AV	Neighborhood 11	COAST LIVE OAK				HOLLY OAK	AFRICAN SUMAC	AUSTRALIAN WILLOW			
STANFORD AV	Neighborhood 12	CRAPE MYRTLE				CRAPE MYRTLE	HOLLY OAK	AFRICAN SUMAC			
STATE ST	District 3	CAROLINA LAUREL CHERRY	CHINESE FRINGE TREE	CHITALPA	REDSPIRE PEAR						
STATE ST	Neighborhood 10	SOUTHERN MAGNOLIA	MAGNOLIA SAINT MARY	CRAPE MYRTLE	CHITALPA	MAGNOLIA SAMUEL SOMMER	AFGHAN PINE	GOLDENRAIN TREE			
STATE ST	Neighborhood 11	SOUTHERN MAGNOLIA				MAGNOLIA SAMUEL SOMMER	AFGHAN PINE	GOLDENRAIN TREE	SOUTHERN MAGNOLIA	CANARY ISLAND PINE	CHINESE FLAME TREE
STATE ST	Neighborhood 14	GUADALUPE PALM				MAGNOLIA SAMUEL SOMMER	AFGHAN PINE	GOLDENRAIN TREE			
STONY BROOK AV	Neighborhood 2	ARIZONA ASH	CHINESE TALLOW TREE			CHINESE TALLOW TREE	CHINESE PISTACHE	AFGHAN PINE			
TAFT AV	Neighborhood 1	CRAPE MYRTLE				CRAPE MYRTLE	TRUE GREEN ELM	AUSTRALIAN WILLOW			
TECUMSEH AV	Neighborhood 11	SOUTHERN MAGNOLIA				MAGNOLIA SAMUEL SOMMER	BOTTLE TREE	ARISTOCRAT PEAR	SOUTHERN MAGNOLIA	BRISBANE BOX	SAWTOOTH ZELKOVA
TECUMSEH AV	Neighborhood 9	CRAPE MYRTLE	CRAPE MYRTLE	ARISTOCRAT PEAR	MAGNOLIA SAINT MARY	CRAPE MYRTLE	MAGNOLIA SAMUEL SOMMER	BOTTLE TREE			
TENAYA AV	Neighborhood 11	CHINESE ELM				DRAKE ELM	MAGNOLIA SAMUEL SOMMER	AFGHAN PINE	DRAKE ELM	CHINESE FLAME TREE	SOUTHERN MAGNOLIA
TENAYA AV	Neighborhood 3	CHINESE ELM				DRAKE ELM	MAGNOLIA SAMUEL SOMMER	CHINESE PISTACHE	DRAKE ELM	CHINESE FLAME TREE	SOUTHERN MAGNOLIA
TENAYA AV	Neighborhood 5	SOUTHERN MAGNOLIA				DRAKE ELM	MAGNOLIA SAMUEL SOMMER	PINK TRUMPET TREE			
TENAYA AV	Neighborhood 8	CAMPBOR TREE				DRAKE ELM	MAGNOLIA SAMUEL SOMMER	NICHOLS WILLOW LEAFED PEPPERMINT			
TENAYA AV	Neighborhood 9	CHINESE ELM	DANCER PEAR	CHITALPA	MAGNOLIA SAINT MARY	DRAKE ELM	MAGNOLIA SAMUEL SOMMER	PINK TRUMPET TREE			
TOPE AV	Neighborhood 12	CHINESE PISTACHE				CHINESE PISTACHE	AUSTRALIAN WILLOW	LAVENDER TRUMPET TREE			
TRUBA AV	Neighborhood 12	SOUTHERN MAGNOLIA				MAGNOLIA SAMUEL SOMMER	DRAKE ELM	MINDANAO GUM			
TWEEDY BL	Corridor D	BRISBANE BOX	HONG KONG ORCHID	CHINESE FRINGE TREE	REDSPIRE PEAR	BOTTLE TREE	INCENSE CEDAR	RED IRONBARK	BRISBANE BOX	SOUTHERN MAGNOLIA	FERN PINE
TWEEDY BL	Neighborhood 10	ORNAMENTAL PEAR	CHANTICLEER PEAR	MAGNOLIA SAINT MARY	WATER GUM						
TWEEDY BL	Neighborhood 11	CARROTWOOD				CHANTICLEER PEAR	MAGNOLIA SAMUEL SOMMER	BOTTLE TREE			
TWEEDY BL	Neighborhood 5	ORNAMENTAL PEAR	CHANTICLEER PEAR	MAGNOLIA SAINT MARY	WATER GUM						
TWEEDY BL	Neighborhood 6	WEEPING FIG	CHANTICLEER PEAR	MAGNOLIA SAINT MARY	WATER GUM						
TWEEDY BL	Neighborhood 7	ORNAMENTAL PEAR	CHANTICLEER PEAR	MAGNOLIA SAINT MARY	WATER GUM						
TWEEDY BL	Neighborhood 8	ORNAMENTAL PEAR	CHANTICLEER PEAR	MAGNOLIA SAINT MARY	WATER GUM						
TWEEDY BL	Neighborhood 9	ORNAMENTAL PEAR	CHANTICLEER PEAR	MAGNOLIA SAINT MARY	WATER GUM						
UTAH AV	District 8	SOUTHERN MAGNOLIA				MAGNOLIA SAMUEL SOMMER	CHINESE TALLOW TREE	MINDANAO GUM			
UTAH AV	Neighborhood 1	CRAPE MYRTLE				CRAPE MYRTLE	AFGHAN PINE	MAGNOLIA SAMUEL SOMMER			
VICTORIA AV	Neighborhood 10	SOUTHERN MAGNOLIA	MAGNOLIA SAINT MARY	CRAPE MYRTLE	CHITALPA	MAGNOLIA SAMUEL SOMMER	BOTTLE TREE	CHINESE TALLOW TREE			
VICTORIA AV	Neighborhood 14	JACARANDA	MAGNOLIA SAINT MARY	CRAPE MYRTLE	CHITALPA	AFGHAN PINE	MAGNOLIA SAMUEL SOMMER	CHINESE TALLOW TREE			

City of South Gate
Street Tree Planting Plan
November 2007

STREET	GENERAL PLAN AREA	CURRENT PRIMARY SPECIES	2-3FT PARKWAYS (GROWING SPACES)			5FT PARKWAYS (GROWING SPACES)			8FT PARKWAYS (GROWING SPACES)		
			RECOMMENDATION 1	RECOMMENDATION 2	RECOMMENDATION 3	RECOMMENDATION 1	RECOMMENDATION 2	RECOMMENDATION 3	RECOMMENDATION 1	RECOMMENDATION 2	RECOMMENDATION 3
VIRGINIA AV	Neighborhood 10	CHINESE ELM	CRAPE MYRTLE	DANCER PEAR	HONG KONG ORCHID TREE	TRUE GREEN ELM	CHINESE TALLOW TREE	HOLLY OAK			
VIRGINIA AV	Neighborhood 14	CHINESE ELM				TRUE GREEN ELM	NICHOL'S WILLOW LEAFED PEPPERMINT	HOLLY OAK			
VIRGINIA AV	Neighborhood 9	CHINESE ELM	CRAPE MYRTLE	DANCER PEAR	HONG KONG ORCHID TREE	TRUE GREEN ELM	NICHOL'S WILLOW LEAFED PEPPERMINT	HOLLY OAK			
VOSSLER AV	Neighborhood 6	LAVENDER TRUMPET TREE				LAVENDER TRUMPET TREE	INCENSE CEDAR	JAPANESE PAGODA TREE			
WALNUT AV	Neighborhood 5	CHINESE ELM				TRUE GREEN ELM	MAIDENHAIR TREE	GOLDENRAIN TREE			
WASHINGTON AV	Neighborhood 5	SOUTHERN MAGNOLIA				MAGNOLIA SAMUEL SOMMER	TULIP TREE	MAIDENHAIR TREE			
WILLOW PL	Neighborhood 10	SOUTHERN MAGNOLIA				MAGNOLIA SAMUEL SOMMER	CHINESE PISTACHE	AFGHAN PINE			
WILLOW PL	Neighborhood 12	CHINESE PISTACHE				CHINESE PISTACHE	MAGNOLIA SAMUEL SOMMER	NICHOL'S WILLOW LEAFED PEPPERMINT			
WILSON AV	District 8	CAROB				MAGNOLIA SAMUEL SOMMER	MINDANAO GUM	CHINESE PISTACHE			
WILSON AV	Neighborhood 1	CRAPE MYRTLE				CRAPE MYRTLE	TRUE GREEN ELM	MINDANAO GUM			
WISCONSIN AV	Neighborhood 11	BOTTLE TREE	CRAPE MYRTLE	MAGNOLIA SAINT MARY	ARISTOCRAT PEAR	BOTTLE TREE	MAGNOLIA SAMUEL SOMMER	INCENSE CEDAR			
WISCONSIN AV	Neighborhood 9	CAMPHOR TREE	CRAPE MYRTLE	MAGNOLIA SAINT MARY	ARISTOCRAT PEAR	BOTTLE TREE	MAGNOLIA SAMUEL SOMMER	INCENSE CEDAR			
WOOD AV	Neighborhood 4	SOUTHERN MAGNOLIA				MAGNOLIA SAMUEL SOMMER	AUSTRALIAN WILLOW	ARISTOCRAT PEAR			
WRIGHT RD	Neighborhood 3	CAROB				TULIP TREE	CRYPTOCARYA RUBRA	GOLDENRAIN TREE			

TREE PLANTING INSTRUCTIONS

1. Trees must be of quality nursery stock, free from pests, disease and structural defects. A 24" boxed tree is recommended unless 15 gal. containers are authorized by the Director of Public Works or City Engineer.

2. Dig planting pit 3X as wide as root ball in compacted soil, 2X in other soils, or as wide as practical per planting location. Planting hole should be centered in the parkway (growing space). Pit should be no deeper than soil in the tree container.

NOTE: If drainage is a concern, the outside perimeter of the pit can be dug deeper to divert excess water away from the root ball. (See diagram)

3. Remove the box bottom from 24" box size trees, or remove the tree and root ball from the container for 15 gal. sized trees. Place the tree in the planting pit. The soil level should be 1" - 2" above the finished grade to allow for some settling. Once the tree is positioned, remove the remainder of the box on larger trees.

4. Backfill the pit ½ way with native soil, add fertilizer tablets if required and enough water to flood the bottom of the pit.

5. Add circular installation of 12" deep root barrier so that the top of the root barrier is just above the finished grade.

6. Complete backfill of pit with native soil, tamping in soil with feet or shovel handle to insure there are no air pockets and that soil is reasonably firm.

7. Prepare earthen water basin capable of holding at least 10 gallons of water.

8. Tree stakes may not be required to support a 24" box sized tree. Should stakes be required, install two 2" X 8' minimum lodgepoles. For 15 gal. sized trees, install two lodgepoles in accordance with South Gate specifications 212, 212A or 212B.

9. Add a 2" deep layer of 3/4" diameter pea gravel on top of compacted soil..

10. For 24" boxed trees, attach the tree to the stake with one pair of soft rubber ties and attach a trunk protector to the base of the tree. For 15 gal. sized trees, install two rigid twist braces in accordance with South Gate specifications 212, 212A or 212B.

CITY OF SOUTH GATE

Planting Detail - 24" Boxed Tree



TRUNK FLARE ABOVE GRADE

KEEP MULCH AWAY FROM TRUNK.
30" MINIMUM DIAMETER BERM
GRASS
CURB AND GUTTER

UNDISTURBED SOIL
COMPACTED TOP SOIL
12" x 60" ROOT BARRIER
PACKED BACKFILL SOIL
FERTILIZER TABLETS
SOIL MOUND BENEATH TREE
STAKES PLACED OUTSIDE ROOTBALL
EXCAVATED SOIL FLARE

2" CINCH TREE TIE
(OR EQUIV.)

2" DIA. X 8' MIN. LODGEPOLE
(OR EQUIV.)

SIDEWALK

2" LAYER PEA GRAVEL
(3/4" DIAMETER)

6' (MIN.)

2" VARIABLE

4" (MIN.)

3 x ROOTBALL IN COMPACTED SOIL
2 x ROOTBALL ALL OTHERS (MIN.)

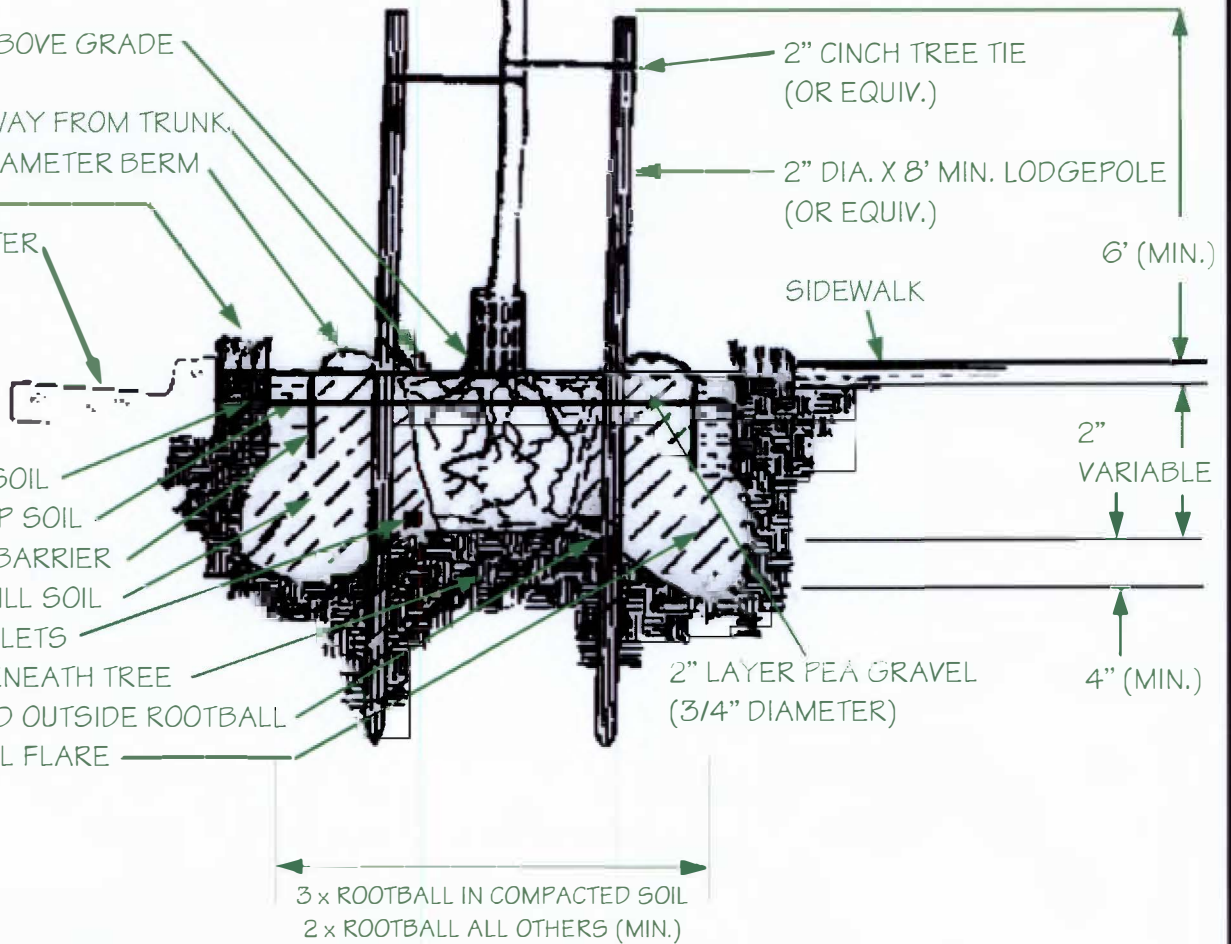

▲ 18" x 5/16" O.D. METAL ROD
ENCASED IN 1/2" I.D.
BLACK VINYL TUBING

MOUNTING PLATE
WELDED TO ROD

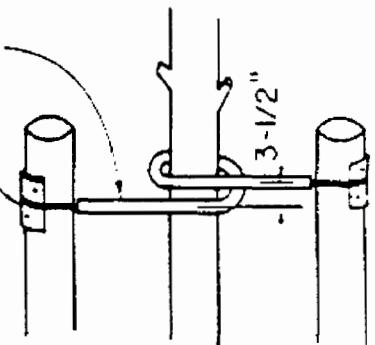

DOUBLE STAKING

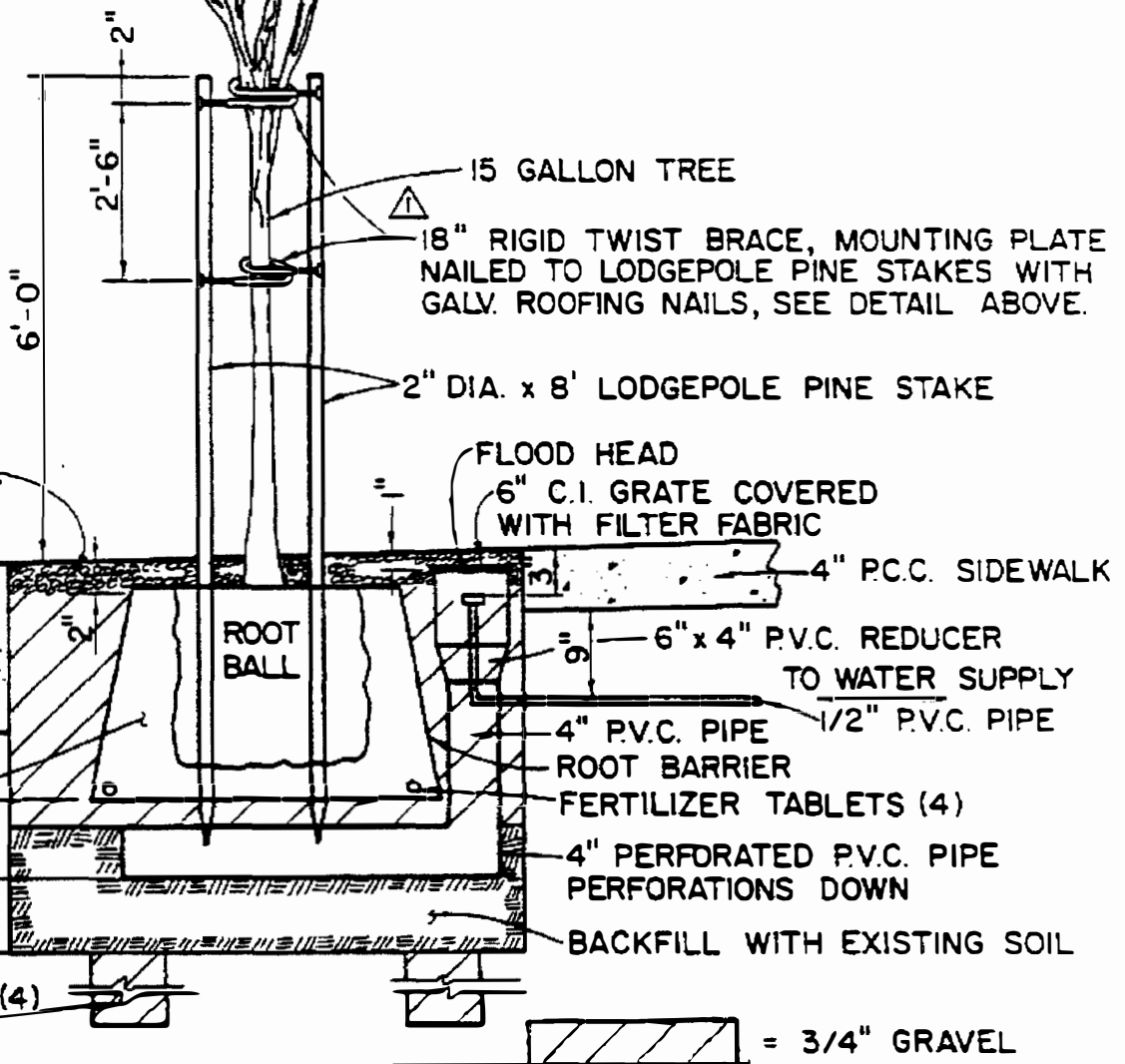

REVISIONS	CITY OF SOUTH GATE	PUBLIC WORKS DEPT.	STANDARD PLAN NO
1	10/85	PARKWAY STREET TREE	
2			
3			
4			
APPROVED BY: <u>James A. Biery</u>		DATE <u>10-01-1990</u>	212
JAMES A. BIERY CITY ENGINEER		R.C.E. NO. 26111	1 OF 3

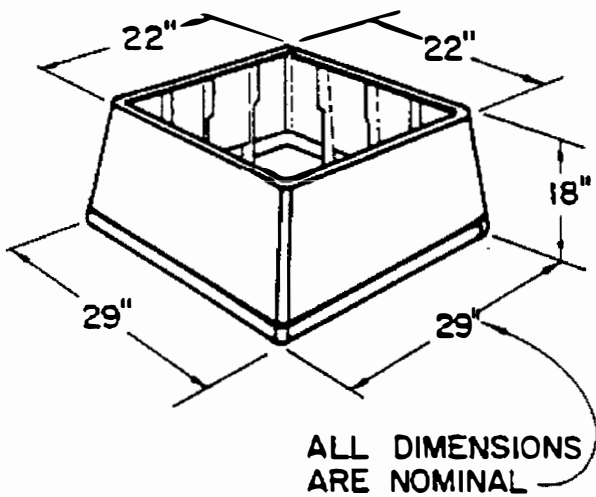
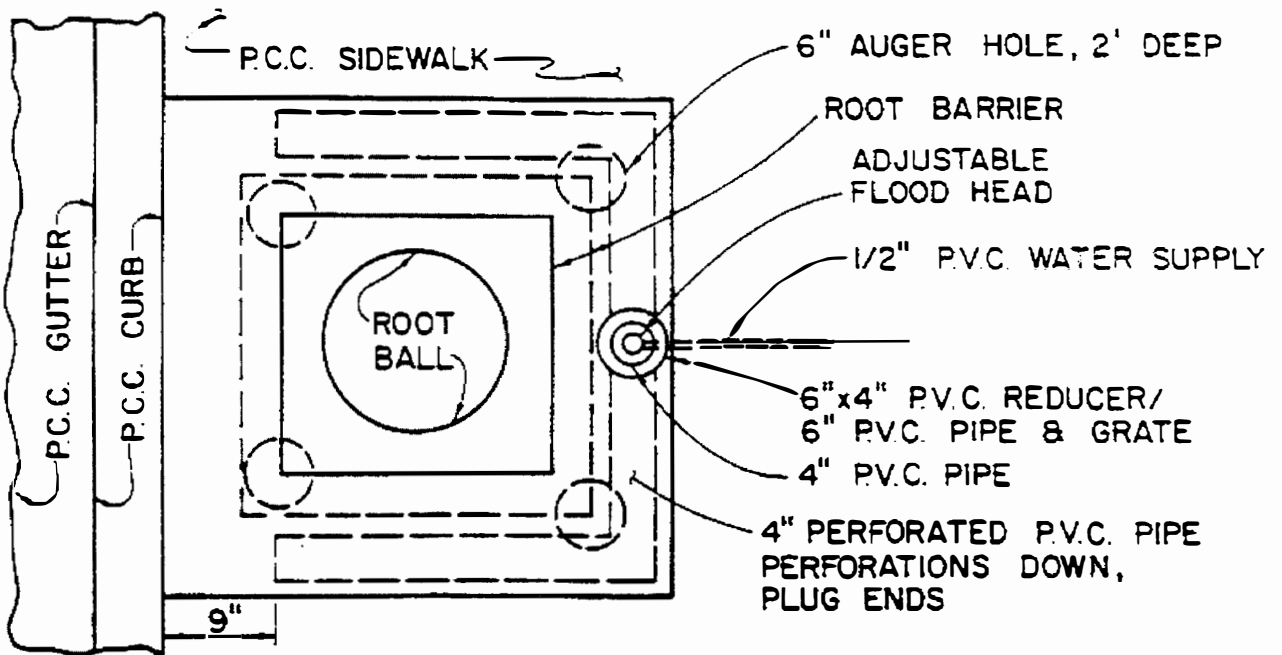

ROOT BARRIER

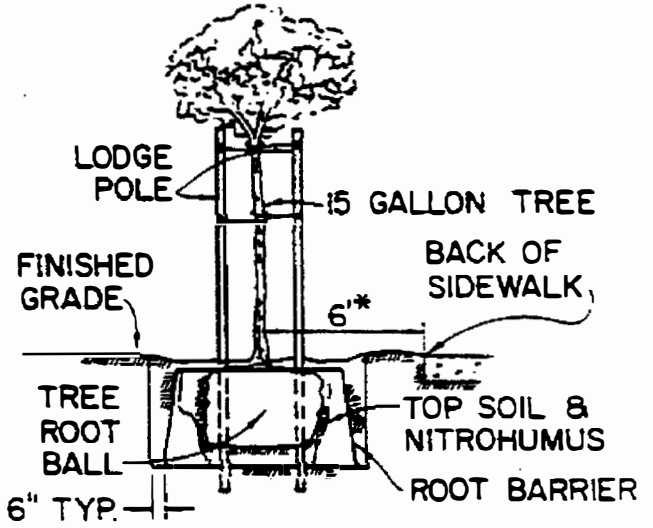

***NOTE: RESIDENTIAL AREAS**
 FOR SIDEYARDS AND REARYARD
 PARKWAYS THIS DISTANCE WILL BE
 DETERMINED BY THE PUBLIC
 WORKS DEPARTMENT.

REVISIONS	CITY OF SOUTH GATE	PUBLIC WORKS DEPT.	STANDARD PLAN NO
	PARKWAY STREET TREE		212
2	APPROVED BY: <i>James A. Bery</i>		DATE 10-01-1990
3	JAMES A. BERY CITY ENGINEER		R.C.E. NO. 26111
4			2 OF 3

NOTES:

1. STREET TREES PLANTED IN PARKWAYS AND PUBLIC RIGHT-OF-WAY SHALL FOLLOW THE REQUIREMENTS SPECIFIED IN THIS STANDARD.
2. STREET TREES SHALL BE PLANTED ALONG STREET FRONTAGES (SEE STANDARD PLAN No. 211) AT LOCATIONS DIRECTED BY THE PUBLIC WORKS DEPARTMENT. THE TREES SHALL BE OF AN ESTABLISHED 15 GALLON STANDARD SIZE AND OF A SPECIES DESIGNATED BY THE PUBLIC WORKS DEPARTMENT.
3. PRIOR TO INSTALLATION, ALL TREES AND HOLES MUST BE INSPECTED AND APPROVED BY THE DEPARTMENT OF PUBLIC WORKS FOR COMPLIANCE WITH THIS STANDARD.
4. ALL TREE HOLES SHALL BE 6" LARGER IN DIAMETER AND 4" DEEPER THAN EXISTING BALL AFTER CONTAINER HAS BEEN REMOVED. AREA BETWEEN BALL, HOLE BOTTOM AND ROOT BARRIER SHALL BE FILLED WITH TOP SOIL AND NITROHUMUS AND WATERED TO PREVENT AIR ENTRAPMENT.
5. ALL TREE HOLES SHALL BE PROVIDED WITH A DEEP WATERING DEVICE MADE WITH SCHEDULE 40 P.V.C. PIPE AS SPECIFIED IN THIS STANDARD. THE ADJUSTABLE FLOW RANGE-FLOOD HEAD SHALL BE BRASS, (ENCLOSED WITH A FILTER-FABRIC SOCK AND SECURED BY A STAINLESS STEEL CLAMP) AND LOCATED A MAXIMUM OF 3" BELOW FINISHED SURFACE. THE WATER SUPPLY SHALL BE CONNECTED TO THE IRRIGATION SYSTEM FOR THE ADJACENT DEVELOPMENT. THE WATERING SCHEDULE SHALL BE COORDINATED WITH THE DEPARTMENT OF PUBLIC WORKS. DEPARTMENT OF PUBLIC WORKS MAY ELIMINATE DEEP WATERING DEVICE.
6. ALL TREES SHALL BE LOCATED, PLANTED AND STAKED AS SPECIFIED IN THIS STANDARD. THE DEPARTMENT OF PUBLIC WORKS SHALL BE NOTIFIED 24 HOURS PRIOR TO PLANTING ANY TREE.
7. ALL TREES SHALL HAVE CONTAINERS REMOVED FOR INSPECTION OF THE ROOT ZONE. ANY TREE FOUND TO BE ROOT BOUND SHALL BE REPLACED.
8. ANY TREE PLANTED WITHIN 6' OF A PUBLIC SIDEWALK SHALL BE SUBJECT TO THE REQUIREMENTS IN THIS STANDARD.
9. ALL TREES MUST BE PLANTED IN A DEEP ROOT BARRIER OR EQUIVALENT AS ILLUSTRATED IN THIS STANDARD. ROOT BARRIER SHALL BE FABRICATED FROM A HIGH DENSITY AND HIGH IMPACT PLASTIC SUCH AS POLYVINYL CHLORIDE, ABS OR POLYETHYLENE AND HAVE A MINIMUM THICKNESS OF 0.06 INCH. THE PLASTIC SHALL HAVE 1/2 INCH TO 3/4 INCH HIGH RAISED VERTICAL RIBS ON THE INNER SURFACE SPACED NOT MORE THAN 6 INCHES TO 8 INCHES APART.
10. TREE STAKES SHALL BE TREATED WITH COPPER NANTHANATE.
11. TREES SHALL BE CENTERED IN TREE WELL OR PARKWAY AS DIRECTED.
12. FERTILIZER TABLETS SHALL BE GRO-POWER 12-8-8.
13. DEPARTMENT OF PUBLIC WORKS MAY SUBSTITUTE OTHER MATERIALS FOR THE PEA GRAVEL THE CAST IRON GRATE SHALL BE COVERED WITH A LOOSE FITTING FERRULE TO PREVENT OTHER MATERIALS FROM ENTERING DEEP WATERING DEVICE AND TO ALLOW WATER TO FLOW OUT OF THE DEVICE.

REVISIONS	CITY OF SOUTH GATE	PUBLIC WORKS DEPT.	STANDARD PLAN NO.
1	PARKWAY STREET TREE		212
2			
3	APPROVED BY: <i>James A. Biery</i>	DATE 10-01-1990	3 OF 3
4	JAMES A. BIERY CITY ENGINEER	R.C.E. NO. 26111	

1 1/2" x 5/16" O.D. METAL ROD
ENCASED IN 1/2" I.D.
BLACK VINYL TUBING

MOUNTING PLATE
WELDED TO ROD

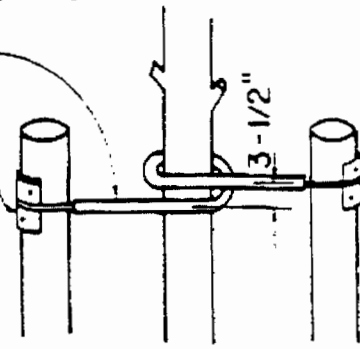

DOUBLE STAKING



15 GALLON TREE

1 1/2" RIGID TWIST BRACE, MOUNTING PLATE
NAILED TO LODGEPOLE PINE STAKES WITH
GALV. ROOFING NAILS, SEE DETAIL ABOVE.

2" DIA. x 8' LODGEPOLE PINE STAKE

FLOOD HEAD

6" C.I. GRATE COVERED
WITH FILTER FABRIC

PEA GRAVEL
P.C.C. CURB
& GUTTER

4" P.C.C. SIDEWALK

ROOT
BALL

6" x 4" P.V.C. REDUCER

TO WATER SUPPLY

4" P.V.C. PIPE

1/2" P.V.C. PIPE

PREPARED
SOIL MIX

ROOT BARRIER

FERTILIZER TABLETS (4)

4" PERFORATED P.V.C. PIPE
PERFORATIONS DOWN

BACKFILL WITH EXISTING SOIL

6" AUGER HOLE (4)
2' DEEP

REVISIONS	CITY OF SOUTH GATE	PUBLIC WORKS DEPT.	STANDARD PLAN NO.
1	PARKWAY STREET TREE		
2			
3	APPROVED BY: <i>James A. Biery</i>	DATE 10-01-1990	212A
4	JAMES A. BIERY	CITY ENGINEER	R.C.E. NO 26111 1 OF 2

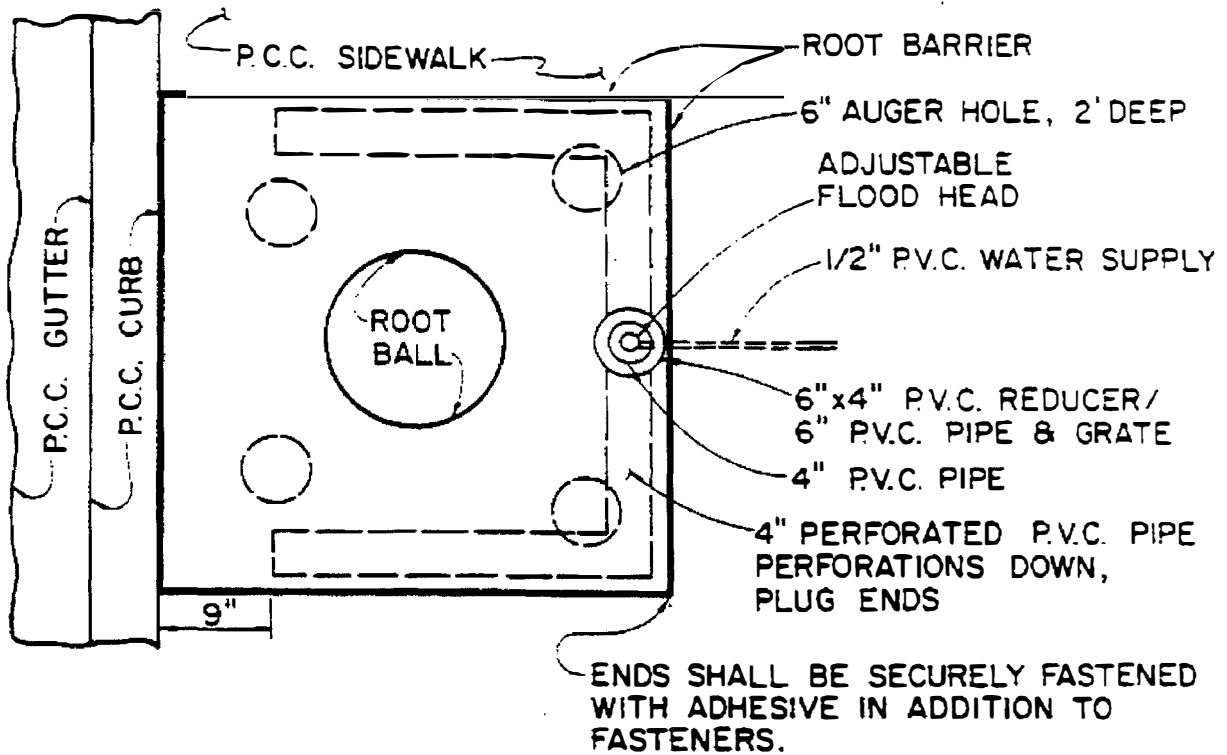

PLAN

NOTE:

- SEE CITY OF SIGNAL HILL STANDARD PLAN No. 212, SHEET 3 OF 3, FOR ALL PERTINENT NOTES.

REVISIONS	CITY OF SOUTH GATE	PUBLIC WORKS DEPT.	STANDARD PLAN NO
2	PARKWAY STREET TREE		212A 2 OF 2
3	APPROVED BY: <i>James A. Biery</i>	DATE 10-01-1990	
4	JAMES A. BIERY	CITY ENGINEER R.C.E. NO. 26111	

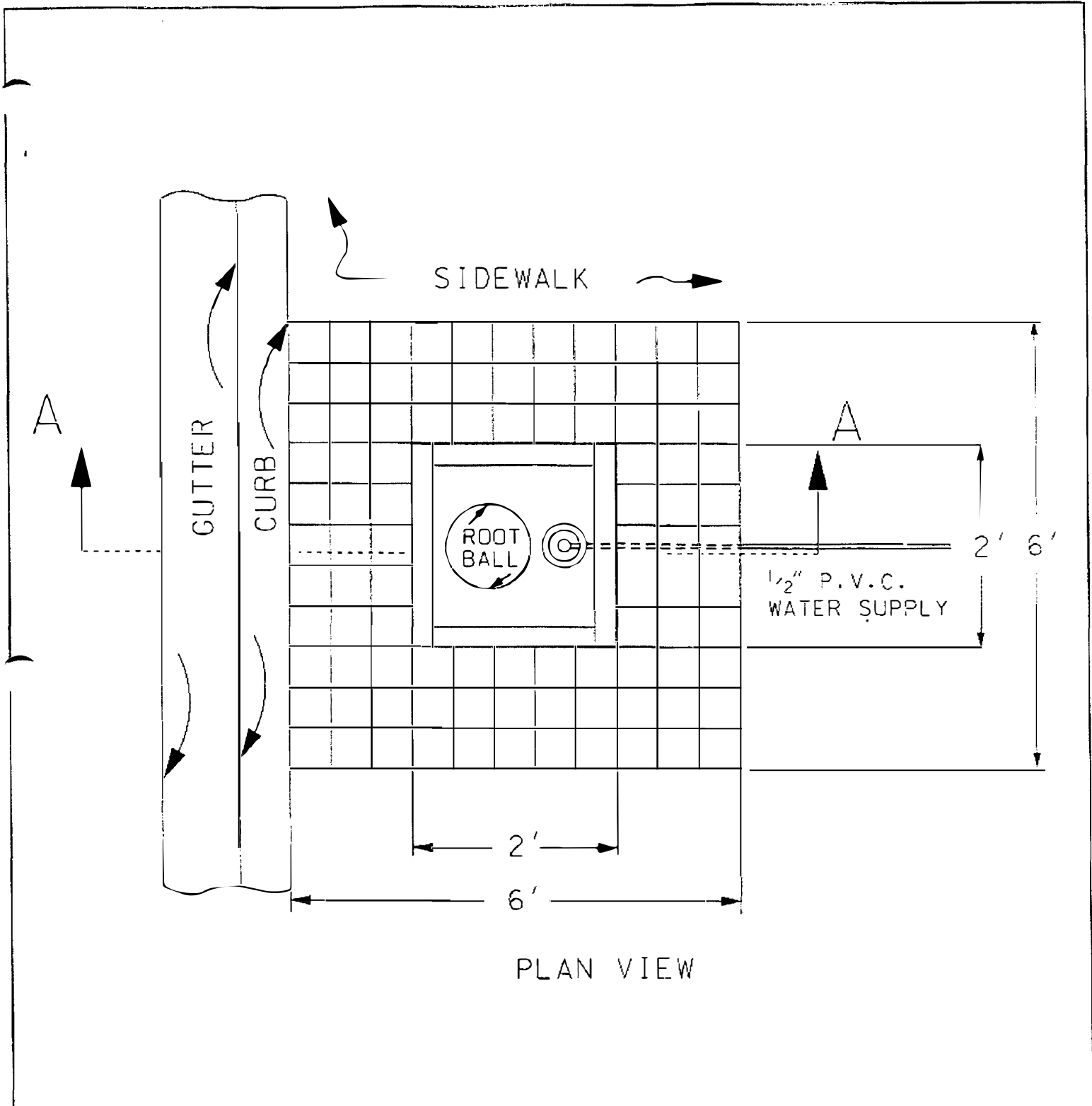

REVISIONS		CITY OF SOUTH GATE	PUBLIC WORKS DEPARTMENT	STANDARD PLAN NO
1		PARKWAY STREET TREE		
3		APPROVED BY: <u>James A. Biery</u>		212B 1 of 4
4		DATE 9-16-96 JAMES A. BIERY CITY ENGINEER RCE NO. 26111		

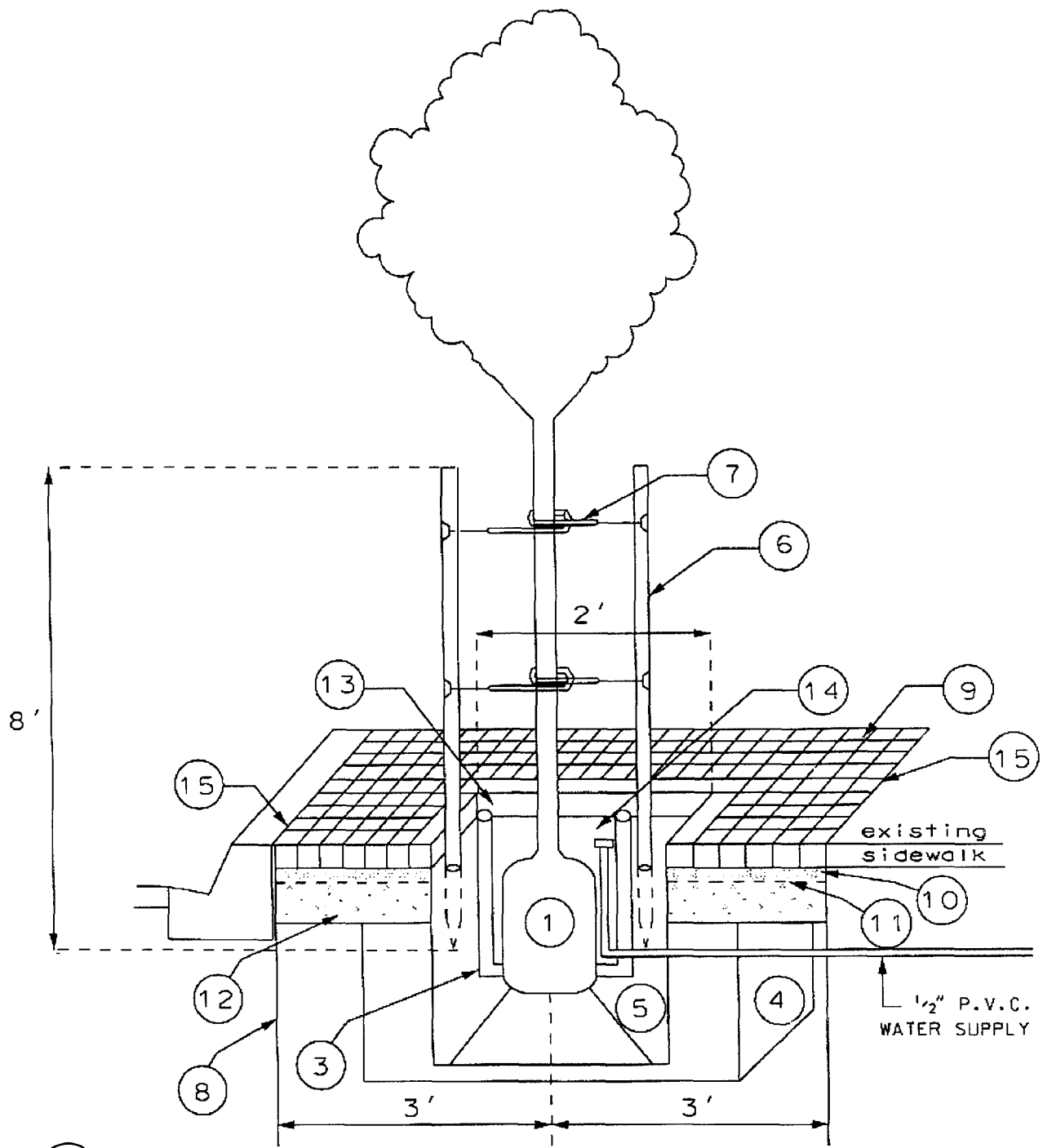

SEE NOTES ON PAGES 3 & 4

SECTION A-A

REVISIONS	CITY OF SOUTH GATE	PUBLIC WORKS DEPARTMENT	STANDARD
1	PARKWAY STREET TREE		PLAN NO
3	APPROVED BY: <i>James A. Biery</i>	DATE 9-16-96	212B 2 of 4
4	JAMES A. BIERY	CITY ENGINEER RCE NO. 26111	

NOTES:

- ① **ROOTBALL** - ROOTBALL SHALL BE FREE OF KINKED AND CIRCLING ROOTS. TOP OF ROOTBALL SHALL BE PLACED 1 INCH ABOVE THE FINISHED SOIL GRADE
- ② **PLANTING HOLE AND DRAINAGE** - PLANTING HOLE SHALL BE A MINIMUM OF 3 FEET SQUARE WITH A DEPTH IN THE CENTER OF HOLE ONE INCH LESS THAN THE DEPTH OF THE ROOTBALL (rootball should sit on a mound of undisturbed soil), AND 6 TO 8 INCHES LOWER ON ALL SIDES. CHECK FOR DRAINAGE. IF SOIL DRAINS LESS THAN 1 INCH PER HOUR, DRILL SIX, 3 INCH DIAMETER HOLES INTO THE HARDPAN TO A DEPTH OF 24 INCHES; FILL WITH PEA GRAVEL. ROOTS ENCOUNTERED WILL BE CUT CLEANLY, WITH A SHARP BLADE. FINAL INSIDE DIMENSION OF TREE WELL IS 2.0' X 2.0'
- ③ **AERATION PIPING** - PLACE TWO "U-SHAPED" 4 INCH DIAMETER PERFORATED, PVC PIPES. WRAPPED IN FILTER FABRIC, ON OPPOSITE SIDES OF THE PLANTING HOLE SO THAT THE OPEN ENDS ARE 1 INCH ABOVE SOIL LEVEL LOCATED AT EACH CORNER. DO NOT FILL THE PIPES. TOP ENDS OF PIPES SHALL BE CAPPED WITH A LOCKING GRATE.
- ④ **BACKFILL** - BACKFILL SHALL BE FREE OF CLODS AND DEBRJ. SOIL MAY REQUIRE AMENDMENT OF ORGANIC MATERIAL. CITY WILL NOTIFY CONTRACTOR AFTER SOIL TESTS ARE PERFORMED. LIGHTLY TAMP IN 8 INCH LAYERS. WATER THOROUGHLY AFTER PLANTING TO SETTLE SOIL. ADD SOIL AS NECESSARY TO ACHIEVE FINISHED GRADE.
- ⑤ **FERTILIZER** - EVENLY SPACED SIX TABLETS OF 21 GRAM AGRIFORM OR APPROVED EQUAL PLANT TABLETS (slow-release fertilizer) EVENLY SPACED WITHIN THE TOP 8 TO 12 INCHES OF SOIL AND 2 INCHES FROM AND SURROUNDING THE ROOTBALL IN EACH TREE WELL.
- ⑥ **STAKES** - USE TWO, 8 FOOT LONG, 2 INCH DIAMETER, PRESSURE-TREATED, PENCIL-POINT, LODGE-POLE PINE STAKES PER TREE. STAKES SHALL BE COUNTERSUNK A MINIMUM OF 2 FEET INTO UNDISTURBED SOIL, AND POSITIONED PERPENDICULAR TO PREVAILING WIND. STAKES SHALL NOT TOUCH THE ROOTBALL. TOP OF STAKES SHALL BE SERVED JUST BELOW THE CANOPY OF THE TREE.
- ⑦ **TIES** - TWO VIT PRODUCTS "TWIST BRACE" (model TB-24) OR APPROVED EQUAL TIES PER TREE SHALL BE USED. THE TIES SHALL BE ATTACHED AT THE LOWEST POINT POSSIBLE TO MAINTAIN THE TREE IN AN UPRIGHT POSITION.
- ⑧ **ROOT DEFLECTOR** - A 24 INCH DEEP ROOT DEFLECTOR SHALL BE LOCATED BETWEEN PAVERS AND EXISTING HARDSCAPE ON ALL FOUR SIDES OF THE TREE.

REVISIONS	CITY OF SOUTH GATE	PUBLIC WORKS DEPARTMENT	STANDARD PLAN NO
1	PARKWAY STREET TREE		
3	APPROVED BY: <u>James A. Biery</u>	DATE 9-16-96	
4	JAMES A. BIERY	CITY ENGINEER RCE NO. 26111	212B 3 of 4

- 9 **PAVERS** - PAVERS SHALL MEET THE FOLLOWING SPECIFICATIONS: COLOR PATTERN ZURICH II, SIZE 60 mm. PAVERS SHALL BE LAID USING INSTALLATION METHODS RECOMMENDED BY THE MANUFACTURER. SOME PAVERS SHALL REQUIRE CUTTING TO FIT IN THE DIMENSION OF THE PAVED AREA. SIZE OF PAVED AREA MAY BE ADJUSTED SLIGHTLY TO MINIMIZE CUTTING. ALL PAVERS SHALL BE LEVEL WITH THE EXISTING SIDEWALK AFTER INSTALLATION. FOR EASE OF FITTING, PAVERS SHOULD BE LAID STARTING AT THE OUTSIDE EDGES AND WORKING IN TOWARD THE CENTER.
- 10 **SAND** - PAVERS SHALL BE PLACED ON TOP OF, AND GENTLY TAMPED INTO, A ONE INCH LAYER OF CLEAN WASHED SAND
- 11 **FILTER FABRIC** - A CONTINUOUS LAYER OF FILTER FABRIC SHALL BE PLACED BETWEEN THE SAND AND GRAVEL.
- 12 **GRAVEL** - A TWO INCH LAYER OF PEA GRAVEL SHALL BE LAID ON TOP OF COMPACTED SOIL.
- 13 **FRAME** - A FRAME WITH AN INSIDE DIMENSION OF APPROXIMATELY 24 INCHES SQUARE. SHALL BE CONSTRUCTED FROM DOUGLAS FIR, PRESSURE-TREATED 2 X 4 LUMBER AND ANCHORED INTO PLACE BY EIGHT DOUGLAS FIR, PRESSURE-TREATED STAKES NO LESS THAN 12 INCHES IN LENGTH PLACED TWO ON EACH SIDE. THIS WILL SERVE TO FRAME THE 2.0' X 2.0' TREE WELL. THE PAVERS SHALL BE BUTTED UPAGAINST THE OUTSIDE OF THE FRAME. THE ACTUAL DIMENSION OF THE FRAME MAY VARY SLIGHTLY TO MINIMIZE THE NEED TO CUT PAVING STONES.
- 14 **TOP DRESSING** - PLACE A FOUR INCH (4") CONTINUOUS LAYER OF PEA GRAVEL ON TOP OF THE OPEN TREE WELL.
- 15 **FLUSH EDGE** - IF A 1/4 INCH OR GREATER GAP EXISTS BETWEEN PAVERS OR BETWEEN PAVERS AND EXISTING SIDEWALK/CURB, NO TYPE OF JOINT FILLER, SUCH AS CONCRETE OR GROUT, SHALL BE USED INSTEAD THE PAVERS SHALL BE MOVED TO BE FLUSH WITH THE OUTSIDE EDGES, AND EITHER THE TREE WELL FRAME (#13) SHALL BE ADJUSTED TO CORRECT THE GAP, OR PAVERS SHALL BE CUT TO AN APPROPRIATE SIZE TO FILL IN THE GAP. CUT PAVERS SHALL BE PLACED ONLY ON THE INSIDE EDGES CLOSEST TO THE TREE WELL.

REVISIONS	CITY OF SOUTH GATE	PUBLIC WORKS DEPARTMENT	STANDARD PLAN NO
1	PARKWAY STREET TREE		
3	APPROVED BY: <u>James A. Biery</u> DATE 9-16-96		
4	JAMES A. BIERY CITY ENGINEER RCE NO. 26111		212B 4 of 4

City of South Gate
Vacant Planting Sites - November 2007

DIST	HOUSE ADDRESS	SIDE	TREE	ON ADDRESS	COMMON NAME	MAINTENANCE
14	5120 ABBOTT RD	Front	1		VACANT SITE	Plant
14	5121 ABBOTT RD	Front	1		VACANT SITE	Plant
14	5125 ABBOTT RD	Front	1		VACANT SITE	Plant
14	5133 ABBOTT RD	Front	1		VACANT SITE	Plant
14	5133 ABBOTT RD	Side	1	10615 X SAINT JAMES AV	VACANT SITE	Plant
14	5136 ABBOTT RD	Side	1	10701 X SAINT JAMES AV	VACANT SITE	Plant
14	5155 ABBOTT RD	Front	1		VACANT SITE	Plant
14	5155 ABBOTT RD	Front	2		VACANT SITE	Plant
14	5166 ABBOTT RD	Side	1	10701 X WRIGHT RD	VACANT SITE	Plant
10	9601 ADELLA AV	Front	1		VACANT SITE	Plant
10	9605 ADELLA AV	Front	1		VACANT SITE	Plant
10	9610 ADELLA AV	Front	1		VACANT SITE	Plant
10	9621 ADELLA AV	Front	1		VACANT SITE	Plant
10	9623 ADELLA AV	Front	1		VACANT SITE	Plant
14	10436 ADELLA AV	Front	1		VACANT SITE	Plant
5	9422 ALAMEDA ST	Front	1		VACANT SITE	Plant
5	9510 ALAMEDA ST	Side	1	2430 X OHIO AV	VACANT SITE	Plant
5	9510 ALAMEDA ST	Side	2	2430 X OHIO AV	VACANT SITE	Plant
5	9618 ALAMEDA ST	Front	1		VACANT SITE	Plant
5	9712 ALAMEDA ST	Front	1		VACANT SITE	Plant
5	9720 ALAMEDA ST	Front	1		VACANT SITE	Plant
14	5217 ALDRICH RD	Front	1		VACANT SITE	Plant
14	5242 ALDRICH RD	Front	1		VACANT SITE	Plant
14	5249 ALDRICH RD	Front	1		VACANT SITE	Plant
14	5258 ALDRICH RD	Front	1		VACANT SITE	Plant
14	5262 ALDRICH RD	Front	1		VACANT SITE	Plant
14	5265 ALDRICH RD	Front	1		VACANT SITE	Plant
14	5268 ALDRICH RD	Front	1		VACANT SITE	Plant
14	5272 ALDRICH RD	Front	1		VACANT SITE	Plant
14	5277 ALDRICH RD	Front	1		VACANT SITE	Plant
14	5278 ALDRICH RD	Side	1	10201 X ADELLA AV	VACANT SITE	Plant
14	5278 ALDRICH RD	Side	2	10201 X ADELLA AV	VACANT SITE	Plant

City of South Gate

Vacant Planting Sites - November 2007

DIST	HOUSE ADDRESS	SIDE	TREE	ON ADDRESS	COMMON NAME	MAINTENANCE
14	5326 ALDRICH RD	Front	1		VACANT SITE	Plant
14	5330 ALDRICH RD	Front	1		VACANT SITE	Plant
14	5336 ALDRICH RD	Front	1		VACANT SITE	Plant
14	5341 ALDRICH RD	Front	1		VACANT SITE	Plant
14	5351 ALDRICH RD	Front	1		VACANT SITE	Plant
14	5356 ALDRICH RD	Front	1		VACANT SITE	Plant
14	5375 ALDRICH RD	Front	1		VACANT SITE	Plant
7	8915 ALEXANDER AV	Front	1		VACANT SITE	Plant
7	8916 ALEXANDER AV	Front	1		VACANT SITE	Plant
7	8917 ALEXANDER AV	Front	1		VACANT SITE	Plant
7	8983 ALEXANDER AV	Front	1		VACANT SITE	Plant
7	8985 ALEXANDER AV	Front	1		VACANT SITE	Plant
7	8994 ALEXANDER AV	Front	1		VACANT SITE	Plant
7	9202 ALEXANDER AV	Side	1	4400 X SOUTHERN AV	VACANT SITE	Plant
9	9312 ALEXANDER AV	Front	1		VACANT SITE	Plant
9	9409 ALEXANDER AV	Front	1		VACANT SITE	Plant
9	9516 ALEXANDER AV	Front	1		VACANT SITE	Plant
9	9520 ALEXANDER AV	Front	1		VACANT SITE	Plant
9	9529 ALEXANDER AV	Front	1		VACANT SITE	Plant
10	9644 ALEXANDER AV	Side	2	4401 X MISSOURI AV	VACANT SITE	Plant
10	9644 ALEXANDER AV	Side	3	4401 X MISSOURI AV	VACANT SITE	Plant
13	10001 ALEXANDER AV	Front	1		VACANT SITE	Plant
13	10100 ALEXANDER AV	Front	1		VACANT SITE	Plant
13	10125 ALEXANDER AV	Front	1		VACANT SITE	Plant
13	10131 ALEXANDER AV	Front	1		VACANT SITE	Plant
13	10211 ALEXANDER AV	Front	1		VACANT SITE	Plant
13	10246 ALEXANDER AV	Front	1		VACANT SITE	Plant
13	10318 ALEXANDER AV	Front	1		VACANT SITE	Plant
13	10319 ALEXANDER AV	Front	1		VACANT SITE	Plant
13	10337 ALEXANDER AV	Front	1		VACANT SITE	Plant
13	10340 ALEXANDER AV	Front	1		VACANT SITE	Plant
13	10341 ALEXANDER AV	Front	1		VACANT SITE	Plant

City of South Gate
Vacant Planting Sites - November 2007

DIST	HOUSE ADDRESS	SIDE	TREE	ON ADDRESS	COMMON NAME	MAINTENANCE
14	10408 ALEXANDER AV	Side	1	4400 X TENAYA AV	VACANT SITE	Plant
13	10409 ALEXANDER AV	Front	1		VACANT SITE	Plant
13	10415 ALEXANDER AV	Front	1		VACANT SITE	Plant
13	10612 ALEXANDER AV	Front	1		VACANT SITE	Plant
14	5206 ALMIRA RD	Side	2	10330 X WRIGHT PL	VACANT SITE	Plant
14	5211 ALMIRA RD	Front	1		VACANT SITE	Plant
14	5236 ALMIRA RD	Front	1		VACANT SITE	Plant
14	5242 ALMIRA RD	Front	1		VACANT SITE	Plant
14	5245 ALMIRA RD	Front	1		VACANT SITE	Plant
14	5251 ALMIRA RD	Front	1		VACANT SITE	Plant
14	5302 ALMIRA RD	Side	1	10330 X ADELLA AV	VACANT SITE	Plant
14	5313 ALMIRA RD	Front	1		VACANT SITE	Plant
14	5318 ALMIRA RD	Front	1		VACANT SITE	Plant
14	5328 ALMIRA RD	Front	1		VACANT SITE	Plant
14	5333 ALMIRA RD	Front	1		VACANT SITE	Plant
14	5334 ALMIRA RD	Front	1		VACANT SITE	Plant
14	5343 ALMIRA RD	Front	1		VACANT SITE	Plant
14	5359 ALMIRA RD	Front	1		VACANT SITE	Plant
16	10705 AMERY AV	Side	1	5830 X MEADOW RD	VACANT SITE	Plant
16	10715 AMERY AV	Front	1		VACANT SITE	Plant
16	10716 AMERY AV	Front	1		VACANT SITE	Plant
16	10726 AMERY AV	Front	1		VACANT SITE	Plant
16	10727 AMERY AV	Front	1		VACANT SITE	Plant
16	10737 AMERY AV	Front	1		VACANT SITE	Plant
16	10814 AMERY AV	Front	1		VACANT SITE	Plant
16	10815 AMERY AV	Front	1		VACANT SITE	Plant
16	10909 AMERY AV	Front	1		VACANT SITE	Plant
16	10910 AMERY AV	Front	1		VACANT SITE	Plant
16	10919 AMERY AV	Front	1		VACANT SITE	Plant
16	10939 AMERY AV	Front	1		VACANT SITE	Plant
16	10949 AMERY AV	Front	1		VACANT SITE	Plant
16	10950 AMERY AV	Front	1		VACANT SITE	Plant

City of South Gate

Vacant Planting Sites - November 2007

DIST	HOUSE ADDRESS	SIDE	TREE	ON ADDRESS	COMMON NAME	MAINTENANCE
16	10970	AMERY AV	Front	1	VACANT SITE	Plant
16	10999	AMERY AV	Front	1	VACANT SITE	Plant
16	11019	AMERY AV	Front	1	VACANT SITE	Plant
16	11020	AMERY AV	Front	1	VACANT SITE	Plant
16	11039	AMERY AV	Front	1	VACANT SITE	Plant
16	11040	AMERY AV	Front	1	VACANT SITE	Plant
16	11049	AMERY AV	Front	1	VACANT SITE	Plant
16	11050	AMERY AV	Front	1	VACANT SITE	Plant
14	5234	ANAHURST RD	Front	1	VACANT SITE	Plant
7	8923	ANNETTA AV	Front	1	VACANT SITE	Plant
7	8936	ANNETTA AV	Front	1	VACANT SITE	Plant
7	8948	ANNETTA AV	Front	1	VACANT SITE	Plant
7	8970	ANNETTA AV	Front	2	VACANT SITE	Plant
7	8976	ANNETTA AV	Front	1	VACANT SITE	Plant
7	8981	ANNETTA AV	Front	1	VACANT SITE	Plant
7	8992	ANNETTA AV	Front	1	VACANT SITE	Plant
7	8993	ANNETTA AV	Front	1	VACANT SITE	Plant
7	9208	ANNETTA AV	Side	1	4630 X SOUTHERN AV	Plant
10	9230	ANNETTA AV	Front	1	VACANT SITE	Plant
10	9329	ANNETTA AV	Front	1	VACANT SITE	Plant
10	9403	ANNETTA AV	Front	1	VACANT SITE	Plant
10	9406	ANNETTA AV	Front	1	VACANT SITE	Plant
10	9415	ANNETTA AV	Side	1	4633 X DUANE WY	Plant
10	9415	ANNETTA AV	Side	2	4633 X DUANE WY	Plant
10	9509	ANNETTA AV	Side	1	4630 X DUANE WY	Plant
10	9611	ANNETTA AV	Front	1	VACANT SITE	Plant
10	9620	ANNETTA AV	Front	1	VACANT SITE	Plant
10	9636	ANNETTA AV	Side	1	4665 X MISSOURI AV	Plant
10	9636	ANNETTA AV	Side	2	4665 X MISSOURI AV	Plant
10	9706	ANNETTA AV	Front	1	VACANT SITE	Plant
10	9707	ANNETTA AV	Side	1	4630 X MISSOURI AV	Plant
10	9707	ANNETTA AV	Side	2	4630 X MISSOURI AV	Plant

City of South Gate
Vacant Planting Sites - November 2007

DIST	HOUSE ADDRESS	SIDE	TREE	ON ADDRESS	COMMON NAME	MAINTENANCE
10	9712 ANNETTA AV	Front	1		VACANT SITE	Plant
10	9713 ANNETTA AV	Front	1		VACANT SITE	Plant
10	9718 ANNETTA AV	Front	1		VACANT SITE	Plant
10	9719 ANNETTA AV	Front	1		VACANT SITE	Plant
10	9820 ANNETTA AV	Front	1		VACANT SITE	Plant
10	9824 ANNETTA AV	Front	1		VACANT SITE	Plant
14	10005 ANNETTA AV	Front	1		VACANT SITE	Plant
14	10008 ANNETTA AV	Front	1		VACANT SITE	Plant
14	10129 ANNETTA AV	Front	1		VACANT SITE	Plant
14	10135 ANNETTA AV	Side	1	4625 X MICHIGAN AV	VACANT SITE	Plant
14	10136 ANNETTA AV	Side	2	4645 X MICHIGAN AV	VACANT SITE	Plant
14	10207 ANNETTA AV	Side	1	4630 X MICHIGAN AV	VACANT SITE	Plant
14	10234 ANNETTA AV	Front	1		VACANT SITE	Plant
14	10336 ANNETTA AV	Front	1		VACANT SITE	Plant
14	10346 ANNETTA AV	Front	1		VACANT SITE	Plant
14	10423 ANNETTA AV	Front	1		VACANT SITE	Plant
14	10430 ANNETTA AV	Front	1		VACANT SITE	Plant
14	10501 ANNETTA AV	Front	1		VACANT SITE	Plant
14	10505 ANNETTA AV	Front	1		VACANT SITE	Plant
14	10509 ANNETTA AV	Front	1		VACANT SITE	Plant
5	2722 ARDMORE AV	Front	1		VACANT SITE	Plant
5	2724 ARDMORE AV	Front	1		VACANT SITE	Plant
5	2728 ARDMORE AV	Front	1		VACANT SITE	Plant
5	2740 ARDMORE AV	Front	1		VACANT SITE	Plant
5	2742 ARDMORE AV	Front	1		VACANT SITE	Plant
5	2748 ARDMORE AV	Front	1		VACANT SITE	Plant
3	2900 ARDMORE AV	Side	2	8600 X MOUNTAIN VIEW AV	VACANT SITE	Plant
3	2920 ARDMORE AV	Front	1		VACANT SITE	Plant
3	3002 ARDMORE AV	Side	3	8600 X EVERGREEN AV	VACANT SITE	Plant
3	3016 ARDMORE AV	Front	1		VACANT SITE	Plant
3	3266 ARDMORE AV	Front	1		VACANT SITE	Plant
3	3270 ARDMORE AV	Front	1		VACANT SITE	Plant

City of South Gate

Vacant Planting Sites - November 2007

DIST	HOUSE ADDRESS	SIDE	TREE	ON ADDRESS	COMMON NAME	MAINTENANCE
3	3274 ARDMORE AV	Side	1	8600 X DEARBORN AV	VACANT SITE	Plant
3	3424 ARDMORE AV	Front	1		VACANT SITE	Plant
3	3424 ARDMORE AV	Side	1	8601 X VIRGINIA AV	VACANT SITE	Plant
3	3424 ARDMORE AV	Side	2	8601 X VIRGINIA AV	VACANT SITE	Plant
3	3424 ARDMORE AV	Side	3	8601 X VIRGINIA AV	VACANT SITE	Plant
4	3600 ARDMORE AV	Front	2		VACANT SITE	Plant
4	3600 ARDMORE AV	Front	3		VACANT SITE	Plant
4	3716 X ARDMORE AV	Front	1		VACANT SITE	Plant
4	3724 ARDMORE AV	Side	1	8601 X SAN GABRIEL AV	VACANT SITE	Plant
4	3926 ARDMORE AV	Side	2	8601 X SAN LUIS AV	VACANT SITE	Plant
4	4020 ARDMORE AV	Front	1		VACANT SITE	Plant
7	8978 ATLANTIC AV	Side	1	4901 X BRANYON AV	VACANT SITE	Plant
7	9005 ATLANTIC AV	Side	1	4925 X SOUTHERN LN	VACANT SITE	Plant
10	9802 ATLANTIC AV	Side	3	5100 X WOOD AV	VACANT SITE	Plant
14	10404 ATLANTIC AV	Side	1	5100 X TENAYA AV	VACANT SITE	Plant
14	10407 ATLANTIC AV	Side	1	5030 X TENAYA AV	VACANT SITE	Plant
14	5204 BATAVIA RD	Front	1		VACANT SITE	Plant
14	5204 BATAVIA RD	Side	2	10300 X WRIGHT PL	VACANT SITE	Plant
14	5223 BATAVIA RD	Front	1		VACANT SITE	Plant
14	5234 BATAVIA RD	Front	1		VACANT SITE	Plant
14	5243 BATAVIA RD	Front	1		VACANT SITE	Plant
14	5249 BATAVIA RD	Front	1		VACANT SITE	Plant
14	5253 BATAVIA RD	Front	1		VACANT SITE	Plant
14	5274 BATAVIA RD	Front	1		VACANT SITE	Plant
14	5274 BATAVIA RD	Side	1	10301 X ADELLA AV	VACANT SITE	Plant
14	5274 BATAVIA RD	Side	2	10301 X ADELLA AV	VACANT SITE	Plant
14	5301 BATAVIA RD	Front	1		VACANT SITE	Plant
14	5301 BATAVIA RD	Side	1	10210 X ADELLA AV	VACANT SITE	Plant
14	5301 BATAVIA RD	Side	2	10210 X ADELLA AV	VACANT SITE	Plant
14	5302 BATAVIA RD	Front	1		VACANT SITE	Plant
14	5302 BATAVIA RD	Side	1	10300 X ADELLA AV	VACANT SITE	Plant
14	5338 BATAVIA RD	Front	1		VACANT SITE	Plant

City of South Gate
Vacant Planting Sites - November 2007

DIST	HOUSE ADDRESS	SIDE	TREE	ON ADDRESS	COMMON NAME	MAINTENANCE
14	5354 BATAVIA RD	Front	1		VACANT SITE	Plant
16	10604 BEAK AV	Front	1		VACANT SITE	Plant
16	10612 BEAK AV	Front	1		VACANT SITE	Plant
16	10617 BEAK AV	Side	1	10600 X CASSINA AV	VACANT SITE	Plant
16	10624 BEAK AV	Front	1		VACANT SITE	Plant
16	10628 BEAK AV	Front	1		VACANT SITE	Plant
16	10633 BEAK AV	Front	1		VACANT SITE	Plant
16	10707 BEAK AV	Side	3	10700 X AMERY AV	VACANT SITE	Plant
16	10710 BEAK AV	Front	1		VACANT SITE	Plant
16	10716 BEAK AV	Front	1		VACANT SITE	Plant
16	10731 BEAK AV	Front	1		VACANT SITE	Plant
16	10731 BEAK AV	Front	2		VACANT SITE	Plant
16	10731 BEAK AV	Front	3		VACANT SITE	Plant
16	10800 BEAK AV	Front	1		VACANT SITE	Plant
16	10821 BEAK AV	Front	1		VACANT SITE	Plant
5	8815 BEAUDINE AV	Front	1		VACANT SITE	Plant
5	8823 BEAUDINE AV	Front	1		VACANT SITE	Plant
5	8843 BEAUDINE AV	Front	1		VACANT SITE	Plant
5	8900 BEAUDINE AV	Front	1		VACANT SITE	Plant
5	8901 BEAUDINE AV	Front	1		VACANT SITE	Plant
5	8917 BEAUDINE AV	Front	1		VACANT SITE	Plant
5	8923 BEAUDINE AV	Front	1		VACANT SITE	Plant
1	8109 BEECHWOOD AV	Front	1		VACANT SITE	Plant
1	8112 BEECHWOOD AV	Front	1		VACANT SITE	Plant
1	8115 BEECHWOOD AV	Front	1		VACANT SITE	Plant
1	8116 BEECHWOOD AV	Front	1		VACANT SITE	Plant
1	8119 BEECHWOOD AV	Front	1		VACANT SITE	Plant
1	8128 X BEECHWOOD AV	Front	1		VACANT SITE	Plant
1	8137 BEECHWOOD AV	Front	1		VACANT SITE	Plant
1	8141 BEECHWOOD AV	Front	1		VACANT SITE	Plant
1	8144 BEECHWOOD AV	Front	1		VACANT SITE	Plant
1	8145 X BEECHWOOD AV	Front	1		VACANT SITE	Plant

City of South Gate

Vacant Planting Sites - November 2007

DIST	HOUSE ADDRESS	SIDE	TREE	ON ADDRESS	COMMON NAME	MAINTENANCE
1	8151 BEECHWOOD AV	Front	1		VACANT SITE	Plant
1	8160 BEECHWOOD AV	Front	1		VACANT SITE	Plant
1	8161 BEECHWOOD AV	Front	1		VACANT SITE	Plant
1	8173 BEECHWOOD AV	Front	1		VACANT SITE	Plant
1	8178 BEECHWOOD AV	Front	1		VACANT SITE	Plant
1	8181 BEECHWOOD AV	Front	1		VACANT SITE	Plant
1	8190 BEECHWOOD AV	Front	1		VACANT SITE	Plant
1	8195 X BEECHWOOD AV	Front	2		VACANT SITE	Plant
1	8432 BEECHWOOD AV	Front	1		VACANT SITE	Plant
1	8456 BEECHWOOD AV	Front	1		VACANT SITE	Plant
1	8457 BEECHWOOD AV	Front	1		VACANT SITE	Plant
1	8460 BEECHWOOD AV	Front	1		VACANT SITE	Plant
1	8480 BEECHWOOD AV	Front	1		VACANT SITE	Plant
1	8480 BEECHWOOD AV	Side	1	2801 X INDEPENDENCE AV	VACANT SITE	Plant
1	8480 BEECHWOOD AV	Side	2	2801 X INDEPENDENCE AV	VACANT SITE	Plant
14	10218 BLUMONT RD	Front	1		VACANT SITE	Plant
14	10336 BLUMONT RD	Front	1		VACANT SITE	Plant
14	10400 BLUMONT RD	Front	1		VACANT SITE	Plant
7	8916 X BOWMAN AV	Front	1		VACANT SITE	Plant
7	8926 BOWMAN AV	Front	1		VACANT SITE	Plant
7	8937 BOWMAN AV	Front	1		VACANT SITE	Plant
7	8980 BOWMAN AV	Front	1		VACANT SITE	Plant
7	8991 BOWMAN AV	Front	1		VACANT SITE	Plant
7	8993 BOWMAN AV	Front	1		VACANT SITE	Plant
7	9202 BOWMAN AV	Side	1	4370 X SOUTHERN AV	VACANT SITE	Plant
7	9202 BOWMAN AV	Side	2	4370 X SOUTHERN AV	VACANT SITE	Plant
7	9202 BOWMAN AV	Side	3	4370 X SOUTHERN AV	VACANT SITE	Plant
7	9203 BOWMAN AV	Side	1	4310 X SOUTHERN AV	VACANT SITE	Plant
7	9203 BOWMAN AV	Side	2	4310 X SOUTHERN AV	VACANT SITE	Plant
9	9312 BOWMAN AV	Front	1		VACANT SITE	Plant
9	9322 BOWMAN AV	Front	1		VACANT SITE	Plant
9	9401 BOWMAN AV	Front	1		VACANT SITE	Plant

City of South Gate
Vacant Planting Sites - November 2007

DIST	HOUSE ADDRESS	SIDE	TREE	ON ADDRESS	COMMON NAME	MAINTENANCE
9	9414 BOWMAN AV	Side	2	4365 X DUANE WY	VACANT SITE	Plant
9	9522 BOWMAN AV	Front	1		VACANT SITE	Plant
9	9526 BOWMAN AV	Front	2		VACANT SITE	Plant
9	9536 BOWMAN AV	Front	1		VACANT SITE	Plant
9	9609 BOWMAN AV	Front	1		VACANT SITE	Plant
9	9624 BOWMAN AV	Front	1		VACANT SITE	Plant
9	9636 BOWMAN AV	Front	1		VACANT SITE	Plant
9	9644 BOWMAN AV	Side	1	4365 X MISSOURI AV	VACANT SITE	Plant
9	9644 BOWMAN AV	Side	2	4365 X MISSOURI AV	VACANT SITE	Plant
9	9645 BOWMAN AV	Side	1	4335 X MISSOURI AV	VACANT SITE	Plant
9	9645 BOWMAN AV	Side	2	4335 X MISSOURI AV	VACANT SITE	Plant
9	9701 BOWMAN AV	Side	1	4330 X MISSOURI AV	VACANT SITE	Plant
9	9718 BOWMAN AV	Front	1		VACANT SITE	Plant
9	9808 BOWMAN AV	Front	1		VACANT SITE	Plant
9	9814 BOWMAN AV	Front	1		VACANT SITE	Plant
9	9822 BOWMAN AV	Front	1		VACANT SITE	Plant
13	10001 BOWMAN AV	Front	1		VACANT SITE	Plant
13	10010 BOWMAN AV	Front	1		VACANT SITE	Plant
13	10019 BOWMAN AV	Front	1		VACANT SITE	Plant
13	10024 BOWMAN AV	Front	1		VACANT SITE	Plant
13	10031 BOWMAN AV	Front	1		VACANT SITE	Plant
13	10040 X BOWMAN AV	Front	1		VACANT SITE	Plant
13	10116 BOWMAN AV	Front	1		VACANT SITE	Plant
13	10210 BOWMAN AV	Front	1		VACANT SITE	Plant
13	10210 BOWMAN AV	Side	1	4350 X MICHIGAN AV	VACANT SITE	Plant
13	10210 BOWMAN AV	Side	2	4350 X MICHIGAN AV	VACANT SITE	Plant
13	10235 BOWMAN AV	Front	1		VACANT SITE	Plant
13	10307 BOWMAN AV	Front	1		VACANT SITE	Plant
13	10341 X BOWMAN AV	Front	1		VACANT SITE	Plant
13	10347 BOWMAN AV	Front	1		VACANT SITE	Plant
13	10352 BOWMAN AV	Side	1	4301 X TENAYA AV	VACANT SITE	Plant
13	10408 BOWMAN AV	Side	3	4300 X TENAYA AV	VACANT SITE	Plant

City of South Gate

Vacant Planting Sites - November 2007

DIST	HOUSE ADDRESS	SIDE	TREE	ON ADDRESS	COMMON NAME	MAINTENANCE
13	10409 BOWMAN AV	Side	1	4280 X TENAYA AV	VACANT SITE	Plant
13	10414 X BOWMAN AV	Front	1		VACANT SITE	Plant
13	10426 BOWMAN AV	Front	1		VACANT SITE	Plant
13	10427 BOWMAN AV	Front	1		VACANT SITE	Plant
13	10526 BOWMAN AV	Front	1		VACANT SITE	Plant
13	10607 BOWMAN AV	Front	1		VACANT SITE	Plant
7	8909 BRYSON AV	Front	1		VACANT SITE	Plant
7	8916 BRYSON AV	Front	1		VACANT SITE	Plant
7	8920 BRYSON AV	Front	1		VACANT SITE	Plant
7	8925 BRYSON AV	Front	1		VACANT SITE	Plant
7	8965 BRYSON AV	Front	1		VACANT SITE	Plant
7	8970 BRYSON AV	Front	1		VACANT SITE	Plant
7	8974 BRYSON AV	Front	1		VACANT SITE	Plant
7	8981 BRYSON AV	Front	1		VACANT SITE	Plant
7	9001 BRYSON AV	Front	1		VACANT SITE	Plant
10	9202 BRYSON AV	Front	1		VACANT SITE	Plant
7	9202 BRYSON AV	Side	2	4440 X SOUTHERN AV	VACANT SITE	Plant
10	9315 BRYSON AV	Front	1		VACANT SITE	Plant
10	9505 BRYSON AV	Side	1	4430 X DUANE WY	VACANT SITE	Plant
10	9520 BRYSON AV	Front	1		VACANT SITE	Plant
10	9524 BRYSON AV	Front	1		VACANT SITE	Plant
10	9535 BRYSON AV	Front	1		VACANT SITE	Plant
10	9604 BRYSON AV	Front	1		VACANT SITE	Plant
10	9626 BRYSON AV	Front	1		VACANT SITE	Plant
10	9636 BRYSON AV	Front	1		VACANT SITE	Plant
10	9707 BRYSON AV	Front	1		VACANT SITE	Plant
10	9731 BRYSON AV	Front	1		VACANT SITE	Plant
10	9801 BRYSON AV	Front	1		VACANT SITE	Plant
10	9805 BRYSON AV	Front	1		VACANT SITE	Plant
10	9813 BRYSON AV	Front	1		VACANT SITE	Plant
10	9821 BRYSON AV	Front	1		VACANT SITE	Plant
14	10011 BRYSON AV	Front	1		VACANT SITE	Plant

City of South Gate
Vacant Planting Sites - November 2007

DIST	HOUSE ADDRESS		SIDE	TREE	ON ADDRESS	COMMON NAME	MAINTENANCE
14	10100	BRYSON AV	Front	2		VACANT SITE	Plant
14	10112	BRYSON AV	Front	1		VACANT SITE	Plant
14	10119	BRYSON AV	Front	1		VACANT SITE	Plant
14	10124	BRYSON AV	Front	1		VACANT SITE	Plant
14	10125	BRYSON AV	Front	1		VACANT SITE	Plant
14	10130	BRYSON AV	Front	1		VACANT SITE	Plant
14	10210	BRYSON AV	Side	1	4440 X MICHIGAN AV	VACANT SITE	Plant
14	10215	BRYSON AV	Front	1		VACANT SITE	Plant
14	10223	BRYSON AV	Front	1		VACANT SITE	Plant
14	10228	BRYSON AV	Front	1		VACANT SITE	Plant
14	10240	BRYSON AV	Front	1		VACANT SITE	Plant
14	10301	BRYSON AV	Front	1		VACANT SITE	Plant
14	10306	BRYSON AV	Front	1		VACANT SITE	Plant
14	10319	BRYSON AV	Front	1		VACANT SITE	Plant
14	10353	BRYSON AV	Side	1	4425 X TENAYA AV	VACANT SITE	Plant
14	10405	BRYSON AV	Side	2	4430 X TENAYA AV	VACANT SITE	Plant
14	10414	BRYSON AV	Front	1		VACANT SITE	Plant
14	10502	BRYSON AV	Front	1		VACANT SITE	Plant
14	10520	BRYSON AV	Front	1		VACANT SITE	Plant
14	10526	BRYSON AV	Front	1		VACANT SITE	Plant
14	10606	BRYSON AV	Front	1		VACANT SITE	Plant
14	10612	BRYSON AV	Front	1		VACANT SITE	Plant
7	8923	BURKE AV	Front	1		VACANT SITE	Plant
7	8931	BURKE AV	Front	1		VACANT SITE	Plant
7	8941	BURKE AV	Front	1		VACANT SITE	Plant
7	8963	BURKE AV	Front	1		VACANT SITE	Plant
7	8975	BURKE AV	Front	1		VACANT SITE	Plant
7	8978	BURKE AV	Front	2		VACANT SITE	Plant
7	8980	BURKE AV	Front	1		VACANT SITE	Plant
7	8991	BURKE AV	Front	1		VACANT SITE	Plant
7	8996	BURKE AV	Front	1		VACANT SITE	Plant
7	9000	BURKE AV	Front	1		VACANT SITE	Plant

City of South Gate

Vacant Planting Sites - November 2007

DIST	HOUSE ADDRESS	SIDE	TREE	ON ADDRESS	COMMON NAME	MAINTENANCE
7	9000 BURKE AV	Front	2		VACANT SITE	Plant
1	8149 CALIFORNIA AV	Front	1		VACANT SITE	Plant
1	8189 CALIFORNIA AV	Front	1		VACANT SITE	Plant
1	8411 CALIFORNIA AV	Front	1		VACANT SITE	Plant
1	8474 X CALIFORNIA AV	Front	1		VACANT SITE	Plant
3	8615 CALIFORNIA AV	Front	1		VACANT SITE	Plant
3	8617 CALIFORNIA AV	Front	1		VACANT SITE	Plant
4	8620 CALIFORNIA AV	Side	1	3500 X ARDMORE AV	VACANT SITE	Plant
4	8620 CALIFORNIA AV	Side	2	3500 X ARDMORE AV	VACANT SITE	Plant
4	8620 CALIFORNIA AV	Side	3	3500 X ARDMORE AV	VACANT SITE	Plant
4	8620 CALIFORNIA AV	Side	4	3500 X ARDMORE AV	VACANT SITE	Plant
3	8627 CALIFORNIA AV	Front	1		VACANT SITE	Plant
3	8645 CALIFORNIA AV	Front	1		VACANT SITE	Plant
3	8653 CALIFORNIA AV	Front	1		VACANT SITE	Plant
3	8655 CALIFORNIA AV	Front	1		VACANT SITE	Plant
3	8691 CALIFORNIA AV	Front	1		VACANT SITE	Plant
3	8691 CALIFORNIA AV	Front	2		VACANT SITE	Plant
3	8691 CALIFORNIA AV	Front	3		VACANT SITE	Plant
6	8924 CALIFORNIA AV	Front	1		VACANT SITE	Plant
6	8927 CALIFORNIA AV	Front	1		VACANT SITE	Plant
6	8944 CALIFORNIA AV	Front	1		VACANT SITE	Plant
6	8985 X CALIFORNIA AV	Front	1		VACANT SITE	Plant
6	8993 CALIFORNIA AV	Front	1		VACANT SITE	Plant
6	8997 CALIFORNIA AV	Front	1		VACANT SITE	Plant
8	9401 CALIFORNIA AV	Front	1		VACANT SITE	Plant
8	9416 CALIFORNIA AV	Front	1		VACANT SITE	Plant
8	9645 CALIFORNIA AV	Front	1		VACANT SITE	Plant
8	9707 CALIFORNIA AV	Front	2		VACANT SITE	Plant
12	10015 CALIFORNIA AV	Front	1		VACANT SITE	Plant
12	10022 CALIFORNIA AV	Front	1		VACANT SITE	Plant
12	10028 CALIFORNIA AV	Front	1		VACANT SITE	Plant
12	10100 CALIFORNIA AV	Front	1		VACANT SITE	Plant

City of South Gate
Vacant Planting Sites - November 2007

DIST	HOUSE ADDRESS	SIDE	TREE	ON ADDRESS	COMMON NAME	MAINTENANCE
12	10120 CALIFORNIA AV	Front	1		VACANT SITE	Plant
12	10120 CALIFORNIA AV	Front	2		VACANT SITE	Plant
13	10206 CALIFORNIA AV	Side	1	3500 X MICHIGAN AV	VACANT SITE	Plant
13	10206 CALIFORNIA AV	Side	2	3500 X MICHIGAN AV	VACANT SITE	Plant
12	10216 CALIFORNIA AV	Front	1		VACANT SITE	Plant
12	10239 CALIFORNIA AV	Front	1		VACANT SITE	Plant
12	10243 CALIFORNIA AV	Front	1		VACANT SITE	Plant
12	10249 CALIFORNIA AV	Front	1		VACANT SITE	Plant
12	10254 CALIFORNIA AV	Front	1		VACANT SITE	Plant
12	10255 CALIFORNIA AV	Front	1		VACANT SITE	Plant
12	10300 CALIFORNIA AV	Front	1		VACANT SITE	Plant
12	10414 CALIFORNIA AV	Front	1		VACANT SITE	Plant
12	10415 CALIFORNIA AV	Front	1		VACANT SITE	Plant
12	10415 CALIFORNIA AV	Front	2		VACANT SITE	Plant
12	10423 CALIFORNIA AV	Front	1		VACANT SITE	Plant
12	10501 CALIFORNIA AV	Front	1		VACANT SITE	Plant
12	10507 CALIFORNIA AV	Front	1		VACANT SITE	Plant
12	10521 CALIFORNIA AV	Front	1		VACANT SITE	Plant
12	10521 CALIFORNIA AV	Front	2		VACANT SITE	Plant
12	10604 CALIFORNIA AV	Front	1		VACANT SITE	Plant
12	10609 CALIFORNIA AV	Front	1		VACANT SITE	Plant
12	10617 CALIFORNIA AV	Front	1		VACANT SITE	Plant
11	9925 X CAPISTRANO AV	Front	4		VACANT SITE	Plant
11	9940 CAPISTRANO AV	Front	1		VACANT SITE	Plant
11	10010 CAPISTRANO AV	Front	1		VACANT SITE	Plant
11	10106 CAPISTRANO AV	Side	1	3100 X WISCONSIN AV	VACANT SITE	Plant
11	10108 CAPISTRANO AV	Front	1		VACANT SITE	Plant
11	10116 CAPISTRANO AV	Front	1		VACANT SITE	Plant
11	10133 CAPISTRANO AV	Front	1		VACANT SITE	Plant
11	10142 CAPISTRANO AV	Front	1		VACANT SITE	Plant
11	10151 CAPISTRANO AV	Front	1		VACANT SITE	Plant
11	10240 CAPISTRANO AV	Front	1		VACANT SITE	Plant

City of South Gate

Vacant Planting Sites - November 2007

DIST	HOUSE ADDRESS	SIDE	TREE	ON ADDRESS	COMMON NAME	MAINTENANCE	
11	10249	CAPISTRANO AV	Front	1		VACANT SITE	Plant
11	10327	CAPISTRANO AV	Front	1		VACANT SITE	Plant
11	10420	CAPISTRANO AV	Front	1		VACANT SITE	Plant
11	10436	CAPISTRANO AV	Front	1		VACANT SITE	Plant
11	10450	CAPISTRANO AV	Front	1		VACANT SITE	Plant
11	10458	CAPISTRANO AV	Side	2	3101 X SEMINOLE AV	VACANT SITE	Plant
11	10508	CAPISTRANO AV	Side	1	3100 X SEMINOLE AV	VACANT SITE	Plant
16	10617	CASSINA AV	Front	1		VACANT SITE	Plant
16	10621	CASSINA AV	Front	1		VACANT SITE	Plant
16	10627	CASSINA AV	Front	1		VACANT SITE	Plant
16	10631	CASSINA AV	Front	1		VACANT SITE	Plant
16	10636	CASSINA AV	Front	1		VACANT SITE	Plant
16	10637	CASSINA AV	Front	1		VACANT SITE	Plant
16	10640	CASSINA AV	Front	1		VACANT SITE	Plant
16	10641	CASSINA AV	Front	1		VACANT SITE	Plant
16	10641	CASSINA AV	Side	1	5815 X MEADOW RD	VACANT SITE	Plant
16	10646	CASSINA AV	Side	1	5825 X MEADOW RD	VACANT SITE	Plant
16	10646	CASSINA AV	Side	2	5825 X MEADOW RD	VACANT SITE	Plant
16	10646	CASSINA AV	Side	3	5825 X MEADOW RD	VACANT SITE	Plant
16	10710	CASSINA AV	Front	1		VACANT SITE	Plant
16	10720	CASSINA AV	Front	1		VACANT SITE	Plant
16	10726	CASSINA AV	Front	1		VACANT SITE	Plant
16	10727	CASSINA AV	Front	1		VACANT SITE	Plant
16	10730	CASSINA AV	Front	1		VACANT SITE	Plant
16	10731	CASSINA AV	Front	1		VACANT SITE	Plant
16	10736	CASSINA AV	Front	1		VACANT SITE	Plant
16	10739	CASSINA AV	Front	1		VACANT SITE	Plant
16	10740	CASSINA AV	Front	1		VACANT SITE	Plant
16	10745	CASSINA AV	Front	1		VACANT SITE	Plant
16	10748	CASSINA AV	Front	1		VACANT SITE	Plant
16	10818	CASSINA AV	Side	1	5825 X LEEDS ST	VACANT SITE	Plant
16	10909	CASSINA AV	Front	1		VACANT SITE	Plant

City of South Gate
Vacant Planting Sites - November 2007

DIST	HOUSE ADDRESS	SIDE	TREE	ON ADDRESS	COMMON NAME	MAINTENANCE
16	10920 CASSINA AV	Front	1		VACANT SITE	Plant
16	10929 CASSINA AV	Front	1		VACANT SITE	Plant
16	10939 CASSINA AV	Front	1		VACANT SITE	Plant
16	10940 CASSINA AV	Front	1		VACANT SITE	Plant
16	10949 CASSINA AV	Front	1		VACANT SITE	Plant
16	10959 CASSINA AV	Front	1		VACANT SITE	Plant
16	11009 CASSINA AV	Front	1		VACANT SITE	Plant
16	11010 CASSINA AV	Front	1		VACANT SITE	Plant
16	11030 CASSINA AV	Front	1		VACANT SITE	Plant
17	11606 CENTER ST	Front	1		VACANT SITE	Plant
17	11616 CENTER ST	Front	1		VACANT SITE	Plant
17	11708 CENTER ST	Front	1		VACANT SITE	Plant
17	11807 CENTER ST	Front	2		VACANT SITE	Plant
17	11910 CENTER ST	Front	1		VACANT SITE	Plant
17	12409 CENTER ST	Front	1		VACANT SITE	Plant
11	2929 CENTURY BL	Side	1	10645 X SAN ANSELMO AV	VACANT SITE	Plant
11	2945 CENTURY BL	Side	1	10640 X SAN ANSELMO AV	VACANT SITE	Plant
11	2973 CENTURY BL	Side	1	10645 X MONTARA AV	VACANT SITE	Plant
11	3057 CENTURY BL	Front	1		VACANT SITE	Plant
11	3069 CENTURY BL	Front	1		VACANT SITE	Plant
11	3109 CENTURY BL	Side	1	10650 X CAPISTRANO AV	VACANT SITE	Plant
11	3117 CENTURY BL	Front	1		VACANT SITE	Plant
11	3125 CENTURY BL	Front	1		VACANT SITE	Plant
11	3169 CENTURY BL	Front	1		VACANT SITE	Plant
11	3171 CENTURY BL	Front	1		VACANT SITE	Plant
11	3177 CENTURY BL	Front	1		VACANT SITE	Plant
11	3181 CENTURY BL	Front	1		VACANT SITE	Plant
11	3219 CENTURY BL	Front	1		VACANT SITE	Plant
11	3227 CENTURY BL	Front	1		VACANT SITE	Plant
11	3227 CENTURY BL	Front	2		VACANT SITE	Plant
17	5621 CENTURY BL	Front	1		VACANT SITE	Plant
17	5621 CENTURY BL	Front	2		VACANT SITE	Plant

City of South Gate

Vacant Planting Sites - November 2007

DIST	HOUSE ADDRESS	SIDE	TREE	ON ADDRESS	COMMON NAME	MAINTENANCE
17	5745 X CENTURY BL	Front	1		VACANT SITE	Plant
11	3144 CHEROKEE AV	Front	2		VACANT SITE	Plant
11	3144 CHEROKEE AV	Front	3		VACANT SITE	Plant
11	3164 CHEROKEE AV	Front	1		VACANT SITE	Plant
12	3287 CHEROKEE AV	Front	1		VACANT SITE	Plant
12	3290 CHEROKEE AV	Front	1		VACANT SITE	Plant
12	3294 CHEROKEE AV	Front	1		VACANT SITE	Plant
12	3299 CHEROKEE AV	Front	1		VACANT SITE	Plant
12	3314 CHEROKEE AV	Front	1		VACANT SITE	Plant
12	3353 CHEROKEE AV	Front	1		VACANT SITE	Plant
12	3362 CHEROKEE AV	Front	1		VACANT SITE	Plant
12	3369 CHEROKEE AV	Front	1		VACANT SITE	Plant
12	3373 CHEROKEE AV	Front	1		VACANT SITE	Plant
12	3378 CHEROKEE AV	Side	1	10349 X ELIZABETH AV	VACANT SITE	Plant
12	3378 CHEROKEE AV	Side	2	10349 X ELIZABETH AV	VACANT SITE	Plant
1	8113 CHESTNUT AV	Front	1		VACANT SITE	Plant
1	8120 CHESTNUT AV	Front	1		VACANT SITE	Plant
1	8122 CHESTNUT AV	Front	1		VACANT SITE	Plant
1	8127 CHESTNUT AV	Front	1		VACANT SITE	Plant
1	8132 CHESTNUT AV	Front	1		VACANT SITE	Plant
1	8137 CHESTNUT AV	Front	1		VACANT SITE	Plant
1	8149 CHESTNUT AV	Front	1		VACANT SITE	Plant
1	8154 CHESTNUT AV	Front	1		VACANT SITE	Plant
1	8160 CHESTNUT AV	Front	1		VACANT SITE	Plant
1	8161 CHESTNUT AV	Front	1		VACANT SITE	Plant
1	8164 CHESTNUT AV	Front	1		VACANT SITE	Plant
1	8165 CHESTNUT AV	Front	1		VACANT SITE	Plant
1	8180 CHESTNUT AV	Front	1		VACANT SITE	Plant
1	8181 CHESTNUT AV	Front	1		VACANT SITE	Plant
1	8183 CHESTNUT AV	Front	1		VACANT SITE	Plant
1	8408 CHESTNUT AV	Front	1		VACANT SITE	Plant
1	8411 CHESTNUT AV	Front	1		VACANT SITE	Plant

City of South Gate
Vacant Planting Sites - November 2007

DIST	HOUSE ADDRESS	SIDE	TREE	ON ADDRESS	COMMON NAME	MAINTENANCE
1	8414 CHESTNUT AV	Front	1		VACANT SITE	Plant
1	8418 CHESTNUT AV	Front	1		VACANT SITE	Plant
1	8422 CHESTNUT AV	Front	1		VACANT SITE	Plant
1	8437 CHESTNUT AV	Front	1		VACANT SITE	Plant
1	8438 CHESTNUT AV	Front	1		VACANT SITE	Plant
1	8444 CHESTNUT AV	Front	1		VACANT SITE	Plant
1	8445 CHESTNUT AV	Front	1		VACANT SITE	Plant
1	8457 CHESTNUT AV	Front	1		VACANT SITE	Plant
1	8460 CHESTNUT AV	Front	1		VACANT SITE	Plant
1	8461 CHESTNUT AV	Front	1		VACANT SITE	Plant
1	8464 CHESTNUT AV	Front	1		VACANT SITE	Plant
1	8481 CHESTNUT AV	Front	1		VACANT SITE	Plant
1	8481 CHESTNUT AV	Side	1	2925 X INDEPENDENCE AV	VACANT SITE	Plant
1	8481 CHESTNUT AV	Side	2	2925 X INDEPENDENCE AV	VACANT SITE	Plant
1	8481 CHESTNUT AV	Side	3	2925 X INDEPENDENCE AV	VACANT SITE	Plant
1	8481 CHESTNUT AV	Side	4	2925 X INDEPENDENCE AV	VACANT SITE	Plant
3	8600 CHESTNUT AV	Side	1	2950 X ARDMORE AV	VACANT SITE	Plant
3	8612 CHESTNUT AV	Front	1		VACANT SITE	Plant
3	8633 CHESTNUT AV	Front	1		VACANT SITE	Plant
3	8659 CHESTNUT AV	Front	1		VACANT SITE	Plant
3	8680 CHESTNUT AV	Front	1		VACANT SITE	Plant
3	8687 CHESTNUT AV	Front	1		VACANT SITE	Plant
17	7315 CLOVERLAWN DR	Front	1		VACANT SITE	Plant
17	7325 CLOVERLAWN DR	Front	1		VACANT SITE	Plant
17	7332 CLOVERLAWN DR	Front	1		VACANT SITE	Plant
17	7346 CLOVERLAWN DR	Front	1		VACANT SITE	Plant
17	7347 CLOVERLAWN DR	Front	1		VACANT SITE	Plant
17	7352 CLOVERLAWN DR	Front	1		VACANT SITE	Plant
17	7353 CLOVERLAWN DR	Front	1		VACANT SITE	Plant
17	7357 CLOVERLAWN DR	Front	1		VACANT SITE	Plant
17	7401 CLOVERLAWN DR	Front	1		VACANT SITE	Plant
17	7409 CLOVERLAWN DR	Front	1		VACANT SITE	Plant

City of South Gate

Vacant Planting Sites - November 2007

DIST	HOUSE ADDRESS	SIDE	TREE	ON ADDRESS	COMMON NAME	MAINTENANCE
17	7415	CLOVERLAWN DR	Front	1	VACANT SITE	Plant
17	7428	CLOVERLAWN DR	Front	1	VACANT SITE	Plant
17	7429	CLOVERLAWN DR	Front	1	VACANT SITE	Plant
17	7435	CLOVERLAWN DR	Front	1	VACANT SITE	Plant
17	7439	CLOVERLAWN DR	Front	1	VACANT SITE	Plant
17	13664	CLOVERLAWN DR	Front	1	VACANT SITE	Plant
17	13670	CLOVERLAWN DR	Front	1	VACANT SITE	Plant
1	8120	COMMERCIAL PL	Front	1	VACANT SITE	Plant
1	8124	COMMERCIAL PL	Front	1	VACANT SITE	Plant
1	8125	COMMERCIAL PL	Front	2	VACANT SITE	Plant
1	8130	COMMERCIAL PL	Front	1	VACANT SITE	Plant
1	8131	COMMERCIAL PL	Front	1	VACANT SITE	Plant
1	8134	COMMERCIAL PL	Front	1	VACANT SITE	Plant
1	8136	COMMERCIAL PL	Front	1	VACANT SITE	Plant
1	8137	COMMERCIAL PL	Front	1	VACANT SITE	Plant
1	8139	COMMERCIAL PL	Front	1	VACANT SITE	Plant
1	8154	COMMERCIAL PL	Front	1	VACANT SITE	Plant
1	8157	COMMERCIAL PL	Front	1	VACANT SITE	Plant
1	8158	COMMERCIAL PL	Front	1	VACANT SITE	Plant
1	8162	COMMERCIAL PL	Front	1	VACANT SITE	Plant
1	8163	COMMERCIAL PL	Front	1	VACANT SITE	Plant
1	8169	COMMERCIAL PL	Front	1	VACANT SITE	Plant
1	8172	COMMERCIAL PL	Front	1	VACANT SITE	Plant
1	8181 X	COMMERCIAL PL	Front	1	VACANT SITE	Plant
1	8112	CYPRESS AV	Front	1	VACANT SITE	Plant
1	8127	CYPRESS AV	Front	1	VACANT SITE	Plant
1	8132	CYPRESS AV	Front	1	VACANT SITE	Plant
1	8140	CYPRESS AV	Front	1	VACANT SITE	Plant
1	8156	CYPRESS AV	Front	1	VACANT SITE	Plant
1	8163	CYPRESS AV	Front	1	VACANT SITE	Plant
1	8164	CYPRESS AV	Front	1	VACANT SITE	Plant
1	8173	CYPRESS AV	Front	1	VACANT SITE	Plant

City of South Gate
Vacant Planting Sites - November 2007

DIST	HOUSE ADDRESS	SIDE	TREE	ON ADDRESS	COMMON NAME	MAINTENANCE
1	8180 CYPRESS AV	Front	1		VACANT SITE	Plant
1	8448 CYPRESS AV	Front	1		VACANT SITE	Plant
1	8449 CYPRESS AV	Front	1		VACANT SITE	Plant
1	8453 CYPRESS AV	Front	1		VACANT SITE	Plant
1	8460 CYPRESS AV	Front	1		VACANT SITE	Plant
1	8461 CYPRESS AV	Front	1		VACANT SITE	Plant
3	8654 CYPRESS AV	Front	1		VACANT SITE	Plant
3	8655 CYPRESS AV	Front	1		VACANT SITE	Plant
3	8660 CYPRESS AV	Front	1		VACANT SITE	Plant
3	8692 CYPRESS AV	Front	1		VACANT SITE	Plant
3	8695 CYPRESS AV	Front	1		VACANT SITE	Plant
6	8953 CYPRESS AV	Front	1		VACANT SITE	Plant
6	8960 CYPRESS AV	Front	1		VACANT SITE	Plant
15	6009 DE PALMA ST	Front	1		VACANT SITE	Plant
15	6017 DE PALMA ST	Front	1		VACANT SITE	Plant
15	6025 DE PALMA ST	Front	1		VACANT SITE	Plant
1	8121 DEARBORN AV	Front	1		VACANT SITE	Plant
1	8125 DEARBORN AV	Front	1		VACANT SITE	Plant
1	8126 DEARBORN AV	Front	1		VACANT SITE	Plant
1	8144 DEARBORN AV	Front	1		VACANT SITE	Plant
1	8158 DEARBORN AV	Front	1		VACANT SITE	Plant
1	8163 DEARBORN AV	Front	1		VACANT SITE	Plant
1	8169 DEARBORN AV	Front	1		VACANT SITE	Plant
1	8180 DEARBORN AV	Front	1		VACANT SITE	Plant
1	8416 DEARBORN AV	Front	1		VACANT SITE	Plant
1	8420 X DEARBORN AV	Front	1		VACANT SITE	Plant
3	8600 X DEARBORN AV	Front	5		VACANT SITE	Plant
3	8657 DEARBORN AV	Front	1		VACANT SITE	Plant
3	8690 X DEARBORN AV	Front	1		VACANT SITE	Plant
3	8690 X DEARBORN AV	Front	2		VACANT SITE	Plant
6	8932 DEARBORN AV	Front	1		VACANT SITE	Plant
6	8939 DEARBORN AV	Front	1		VACANT SITE	Plant

City of South Gate

Vacant Planting Sites - November 2007

DIST	HOUSE ADDRESS	SIDE	TREE	ON ADDRESS	COMMON NAME	MAINTENANCE
6	8959 DEARBORN AV	Front	1		VACANT SITE	Plant
6	9205 DEARBORN AV	Side	1	3290 X SOUTHERN AV	VACANT SITE	Plant
8	9308 DEARBORN AV	Front	1		VACANT SITE	Plant
8	9400 DEARBORN AV	Front	1		VACANT SITE	Plant
8	9420 DEARBORN AV	Side	2	3301 X DUANE WY	VACANT SITE	Plant
8	9501 DEARBORN AV	Front	1		VACANT SITE	Plant
8	9504 DEARBORN AV	Side	1	3300 X DUANE WY	VACANT SITE	Plant
8	9504 DEARBORN AV	Side	3	3300 X DUANE WY	VACANT SITE	Plant
8	9520 DEARBORN AV	Front	1		VACANT SITE	Plant
8	9525 DEARBORN AV	Front	1		VACANT SITE	Plant
8	9837 DEARBORN AV	Front	1		VACANT SITE	Plant
8	9230 DEEBLE ST	Front	1		VACANT SITE	Plant
8	9318 DEEBLE ST	Front	1		VACANT SITE	Plant
8	9320 DEEBLE ST	Front	1		VACANT SITE	Plant
8	9321 X DEEBLE ST	Front	1		VACANT SITE	Plant
8	9335 X DEEBLE ST	Front	1		VACANT SITE	Plant
8	9506 DEEBLE ST	Side	1	3270 X DUANE WY	VACANT SITE	Plant
8	9534 DEEBLE ST	Front	1		VACANT SITE	Plant
8	9558 DEEBLE ST	Front	1		VACANT SITE	Plant
8	9600 DEEBLE ST	Front	1		VACANT SITE	Plant
8	9608 DEEBLE ST	Front	1		VACANT SITE	Plant
8	9706 DEEBLE ST	Side	1	3270 X MISSOURI AV	VACANT SITE	Plant
8	9832 DEEBLE ST	Front	1		VACANT SITE	Plant
7	8916 DOROTHY AV	Front	1		VACANT SITE	Plant
7	8918 DOROTHY AV	Front	1		VACANT SITE	Plant
7	8934 DOROTHY AV	Front	1		VACANT SITE	Plant
7	8945 DOROTHY AV	Front	1		VACANT SITE	Plant
7	8946 X DOROTHY AV	Front	1		VACANT SITE	Plant
7	8950 DOROTHY AV	Front	1		VACANT SITE	Plant
7	8991 DOROTHY AV	Front	1		VACANT SITE	Plant
7	8998 DOROTHY AV	Front	1		VACANT SITE	Plant
7	9208 DOROTHY AV	Side	1	4530 X SOUTHERN AV	VACANT SITE	Plant

City of South Gate
Vacant Planting Sites - November 2007

DIST	HOUSE ADDRESS	SIDE	TREE	ON ADDRESS	COMMON NAME	MAINTENANCE
7	9208 DOROTHY AV	Side	2	4530 X SOUTHERN AV	VACANT SITE	Plant
7	9209 DOROTHY AV	Side	1	4510 X SOUTHERN AV	VACANT SITE	Plant
10	9214 DOROTHY AV	Front	1		VACANT SITE	Plant
10	9218 DOROTHY AV	Front	1		VACANT SITE	Plant
10	9223 DOROTHY AV	Front	1		VACANT SITE	Plant
10	9228 DOROTHY AV	Front	1		VACANT SITE	Plant
10	9300 DOROTHY AV	Front	1		VACANT SITE	Plant
10	9303 DOROTHY AV	Front	1		VACANT SITE	Plant
10	9315 DOROTHY AV	Front	1		VACANT SITE	Plant
10	9324 DOROTHY AV	Front	1		VACANT SITE	Plant
10	9406 DOROTHY AV	Front	1		VACANT SITE	Plant
10	9414 DOROTHY AV	Side	1	4575 X DUANE WY	VACANT SITE	Plant
10	9414 DOROTHY AV	Side	2	4575 X DUANE WY	VACANT SITE	Plant
10	9415 DOROTHY AV	Front	1		VACANT SITE	Plant
10	9415 DOROTHY AV	Side	1	4533 X DUANE WY	VACANT SITE	Plant
10	9415 DOROTHY AV	Side	2	4533 X DUANE WY	VACANT SITE	Plant
10	9509 DOROTHY AV	Side	1	4530 X DUANE WY	VACANT SITE	Plant
10	9510 DOROTHY AV	Side	1	4560 X DUANE WY	VACANT SITE	Plant
10	9514 DOROTHY AV	Front	1		VACANT SITE	Plant
10	9524 DOROTHY AV	Front	1		VACANT SITE	Plant
10	9533 DOROTHY AV	Front	1		VACANT SITE	Plant
10	9534 DOROTHY AV	Front	1		VACANT SITE	Plant
10	9609 DOROTHY AV	Front	1		VACANT SITE	Plant
10	9629 DOROTHY AV	Front	1		VACANT SITE	Plant
10	9638 DOROTHY AV	Side	2	4565 X MISSOURI AV	VACANT SITE	Plant
10	9704 DOROTHY AV	Side	1	4570 X MISSOURI AV	VACANT SITE	Plant
10	9704 DOROTHY AV	Side	2	4570 X MISSOURI AV	VACANT SITE	Plant
10	9707 DOROTHY AV	Front	1		VACANT SITE	Plant
10	9710 DOROTHY AV	Front	1		VACANT SITE	Plant
10	9714 DOROTHY AV	Front	1		VACANT SITE	Plant
10	9722 DOROTHY AV	Front	1		VACANT SITE	Plant
10	9725 DOROTHY AV	Front	1		VACANT SITE	Plant

City of South Gate

Vacant Planting Sites - November 2007

DIST	HOUSE ADDRESS	SIDE	TREE	ON ADDRESS	COMMON NAME	MAINTENANCE	
10	9807	DOROTHY AV	Front	1		VACANT SITE	Plant
10	9811	DOROTHY AV	Front	1		VACANT SITE	Plant
14	10025	DOROTHY AV	Front	1		VACANT SITE	Plant
14	10247	DOROTHY AV	Front	1		VACANT SITE	Plant
14	10328	DOROTHY AV	Front	1		VACANT SITE	Plant
14	10329	DOROTHY AV	Front	1		VACANT SITE	Plant
14	10336	DOROTHY AV	Front	1		VACANT SITE	Plant
14	10346	DOROTHY AV	Side	2	4501 X TENAYA AV	VACANT SITE	Plant
14	10514	DOROTHY AV	Front	1		VACANT SITE	Plant
14	10515	DOROTHY AV	Front	1		VACANT SITE	Plant
8	3275	DUANE WY	Side	1	9420 X DEEBLE ST	VACANT SITE	Plant
8	3280	DUANE WY	Front	1		VACANT SITE	Plant
8	3348	DUANE WY	Front	1		VACANT SITE	Plant
8	3464	DUANE WY	Front	1		VACANT SITE	Plant
9	3605	DUANE WY	Side	1	9410 X SAN ANTONIO AV	VACANT SITE	Plant
9	3636	DUANE WY	Side	2	9501 X SAN CARLOS AV	VACANT SITE	Plant
9	3810	DUANE WY	Front	1		VACANT SITE	Plant
9	3810	DUANE WY	Front	2		VACANT SITE	Plant
9	3832	DUANE WY	Front	1		VACANT SITE	Plant
9	3844	DUANE WY	Front	1		VACANT SITE	Plant
9	3918	DUANE WY	Front	1		VACANT SITE	Plant
9	4167	DUANE WY	Front	1		VACANT SITE	Plant
9	4175	DUANE WY	Front	1		VACANT SITE	Plant
9	4224	DUANE WY	Front	1		VACANT SITE	Plant
9	4312	DUANE WY	Front	1		VACANT SITE	Plant
9	4317	DUANE WY	Front	1		VACANT SITE	Plant
10	4409	DUANE WY	Front	1		VACANT SITE	Plant
10	4417	DUANE WY	Front	1		VACANT SITE	Plant
7	8915	DUDLEXT AV	Front	1		VACANT SITE	Plant
7	8916	DUDLEXT AV	Front	1		VACANT SITE	Plant
7	8922	DUDLEXT AV	Front	1		VACANT SITE	Plant
7	8926	DUDLEXT AV	Front	1		VACANT SITE	Plant

City of South Gate
Vacant Planting Sites - November 2007

DIST	HOUSE ADDRESS	SIDE	TREE	ON ADDRESS	COMMON NAME	MAINTENANCE
7	8939 DUDLEXT AV	Front	1		VACANT SITE	Plant
7	8942 DUDLEXT AV	Front	1		VACANT SITE	Plant
7	8952 DUDLEXT AV	Front	1		VACANT SITE	Plant
10	5123 DUNCAN WY	Front	1		VACANT SITE	Plant
10	5126 DUNCAN WY	Front	1		VACANT SITE	Plant
10	5130 DUNCAN WY	Front	1		VACANT SITE	Plant
10	5137 DUNCAN WY	Front	1		VACANT SITE	Plant
10	5138 DUNCAN WY	Front	1		VACANT SITE	Plant
10	5140 DUNCAN WY	Front	1		VACANT SITE	Plant
10	5143 DUNCAN WY	Front	1		VACANT SITE	Plant
10	5147 DUNCAN WY	Front	1		VACANT SITE	Plant
10	5155 DUNCAN WY	Front	1		VACANT SITE	Plant
10	5159 DUNCAN WY	Front	1		VACANT SITE	Plant
10	5167 DUNCAN WY	Front	1		VACANT SITE	Plant
10	5179 DUNCAN WY	Front	1		VACANT SITE	Plant
10	5182 DUNCAN WY	Front	1		VACANT SITE	Plant
10	5183 DUNCAN WY	Front	1		VACANT SITE	Plant
10	5187 DUNCAN WY	Front	1		VACANT SITE	Plant
10	5194 DUNCAN WY	Side	1	9701 X ADELLA AV	VACANT SITE	Plant
10	5205 DUNCAN WY	Side	1	9650 X ADELLA AV	VACANT SITE	Plant
10	5205 DUNCAN WY	Side	2	9650 X ADELLA AV	VACANT SITE	Plant
10	5206 DUNCAN WY	Side	2	9700 X ADELLA AV	VACANT SITE	Plant
10	5214 DUNCAN WY	Front	1		VACANT SITE	Plant
10	5217 DUNCAN WY	Front	1		VACANT SITE	Plant
10	5218 X DUNCAN WY	Front	1		VACANT SITE	Plant
10	5221 DUNCAN WY	Front	1		VACANT SITE	Plant
10	5225 DUNCAN WY	Front	1		VACANT SITE	Plant
10	5229 DUNCAN WY	Front	1		VACANT SITE	Plant
10	5247 DUNCAN WY	Front	1		VACANT SITE	Plant
10	5247 DUNCAN WY	Front	2		VACANT SITE	Plant
1	8114 ELIZABETH AV	Front	1		VACANT SITE	Plant
1	8120 ELIZABETH AV	Front	1		VACANT SITE	Plant

City of South Gate

Vacant Planting Sites - November 2007

DIST	HOUSE ADDRESS	SIDE	TREE	ON ADDRESS	COMMON NAME	MAINTENANCE
1	8135 ELIZABETH AV	Front	1		VACANT SITE	Plant
1	8135 ELIZABETH AV	Front	2		VACANT SITE	Plant
1	8141 ELIZABETH AV	Front	1		VACANT SITE	Plant
1	8144 ELIZABETH AV	Front	1		VACANT SITE	Plant
1	8148 ELIZABETH AV	Front	1		VACANT SITE	Plant
1	8149 ELIZABETH AV	Front	1		VACANT SITE	Plant
1	8164 ELIZABETH AV	Front	1		VACANT SITE	Plant
1	8175 ELIZABETH AV	Front	1		VACANT SITE	Plant
1	8179 ELIZABETH AV	Front	1		VACANT SITE	Plant
1	8185 ELIZABETH AV	Front	1		VACANT SITE	Plant
1	8407 ELIZABETH AV	Front	1		VACANT SITE	Plant
1	8411 ELIZABETH AV	Front	1		VACANT SITE	Plant
1	8414 ELIZABETH AV	Front	1		VACANT SITE	Plant
1	8422 ELIZABETH AV	Front	1		VACANT SITE	Plant
1	8426 ELIZABETH AV	Front	1		VACANT SITE	Plant
1	8430 ELIZABETH AV	Front	1		VACANT SITE	Plant
1	8433 ELIZABETH AV	Front	1		VACANT SITE	Plant
1	8443 ELIZABETH AV	Front	1		VACANT SITE	Plant
1	8464 ELIZABETH AV	Front	1		VACANT SITE	Plant
1	8471 ELIZABETH AV	Front	1		VACANT SITE	Plant
1	8475 ELIZABETH AV	Front	1		VACANT SITE	Plant
1	8479 ELIZABETH AV	Side	1	3375 X INDEPENDENCE AV	VACANT SITE	Plant
1	8479 ELIZABETH AV	Side	2	3375 X INDEPENDENCE AV	VACANT SITE	Plant
6	8916 ELIZABETH AV	Front	1		VACANT SITE	Plant
6	8920 ELIZABETH AV	Front	1		VACANT SITE	Plant
6	8933 ELIZABETH AV	Front	1		VACANT SITE	Plant
6	8942 ELIZABETH AV	Front	1		VACANT SITE	Plant
6	8974 ELIZABETH AV	Front	1		VACANT SITE	Plant
6	8988 ELIZABETH AV	Front	1		VACANT SITE	Plant
6	8992 ELIZABETH AV	Front	1		VACANT SITE	Plant
8	9226 ELIZABETH AV	Front	1		VACANT SITE	Plant
8	9421 ELIZABETH AV	Side	1	3365 X DUANE WY	VACANT SITE	Plant

City of South Gate
Vacant Planting Sites - November 2007

DIST	HOUSE ADDRESS	SIDE	TREE	ON ADDRESS	COMMON NAME	MAINTENANCE
8	9505 ELIZABETH AV	Side	2	3390 X DUANE WY	VACANT SITE	Plant
8	9549 ELIZABETH AV	Front	1		VACANT SITE	Plant
8	9601 ELIZABETH AV	Front	1		VACANT SITE	Plant
8	9605 ELIZABETH AV	Front	1		VACANT SITE	Plant
8	9613 ELIZABETH AV	Front	1		VACANT SITE	Plant
8	9617 ELIZABETH AV	Front	1		VACANT SITE	Plant
8	9632 ELIZABETH AV	Front	1		VACANT SITE	Plant
8	9641 ELIZABETH AV	Front	1		VACANT SITE	Plant
8	9641 ELIZABETH AV	Side	1	3359 X MISSOURI AV	VACANT SITE	Plant
8	9641 ELIZABETH AV	Side	2	3359 X MISSOURI AV	VACANT SITE	Plant
8	9719 ELIZABETH AV	Front	1		VACANT SITE	Plant
8	9836 ELIZABETH AV	Front	1		VACANT SITE	Plant
8	9836 ELIZABETH AV	Front	2		VACANT SITE	Plant
12	9920 ELIZABETH AV	Front	1		VACANT SITE	Plant
12	10000 ELIZABETH AV	Front	1		VACANT SITE	Plant
12	10023 ELIZABETH AV	Front	1		VACANT SITE	Plant
12	10032 ELIZABETH AV	Front	1		VACANT SITE	Plant
12	10120 ELIZABETH AV	Front	1		VACANT SITE	Plant
12	10127 ELIZABETH AV	Front	1		VACANT SITE	Plant
12	10131 ELIZABETH AV	Front	1		VACANT SITE	Plant
12	10136 ELIZABETH AV	Front	1		VACANT SITE	Plant
12	10226 ELIZABETH AV	Front	1		VACANT SITE	Plant
12	10230 ELIZABETH AV	Front	1		VACANT SITE	Plant
12	10348 ELIZABETH AV	Front	1		VACANT SITE	Plant
12	10501 ELIZABETH AV	Front	1		VACANT SITE	Plant
12	10524 ELIZABETH AV	Front	1		VACANT SITE	Plant
12	10532 ELIZABETH AV	Front	1		VACANT SITE	Plant
12	10600 ELIZABETH AV	Front	1		VACANT SITE	Plant
12	10608 ELIZABETH AV	Front	1		VACANT SITE	Plant
12	10612 ELIZABETH AV	Front	1		VACANT SITE	Plant
12	10615 ELIZABETH AV	Front	1		VACANT SITE	Plant
1	8118 EVERGREEN AV	Front	1		VACANT SITE	Plant

City of South Gate

Vacant Planting Sites - November 2007

DIST	HOUSE ADDRESS	SIDE	TREE	ON ADDRESS	COMMON NAME	MAINTENANCE
1	8120	EVERGREEN AV	Front	1	VACANT SITE	Plant
1	8124	EVERGREEN AV	Front	1	VACANT SITE	Plant
1	8127	EVERGREEN AV	Front	1	VACANT SITE	Plant
1	8139	EVERGREEN AV	Front	1	VACANT SITE	Plant
1	8142	EVERGREEN AV	Front	1	VACANT SITE	Plant
1	8143	EVERGREEN AV	Front	1	VACANT SITE	Plant
1	8146	EVERGREEN AV	Front	1	VACANT SITE	Plant
1	8147	EVERGREEN AV	Front	1	VACANT SITE	Plant
1	8151	EVERGREEN AV	Front	1	VACANT SITE	Plant
1	8176	EVERGREEN AV	Front	1	VACANT SITE	Plant
1	8181	EVERGREEN AV	Front	1	VACANT SITE	Plant
1	8189	EVERGREEN AV	Front	1	VACANT SITE	Plant
1	8415	EVERGREEN AV	Front	1	VACANT SITE	Plant
1	8416	EVERGREEN AV	Front	1	VACANT SITE	Plant
1	8417	EVERGREEN AV	Front	1	VACANT SITE	Plant
1	8420	EVERGREEN AV	Front	1	VACANT SITE	Plant
1	8430	EVERGREEN AV	Front	1	VACANT SITE	Plant
1	8432	EVERGREEN AV	Front	1	VACANT SITE	Plant
1	8436	EVERGREEN AV	Front	1	VACANT SITE	Plant
1	8443	EVERGREEN AV	Front	1	VACANT SITE	Plant
1	8451	EVERGREEN AV	Front	3	VACANT SITE	Plant
1	8452	EVERGREEN AV	Front	1	VACANT SITE	Plant
1	8458	EVERGREEN AV	Front	1	VACANT SITE	Plant
1	8472	EVERGREEN AV	Front	1	VACANT SITE	Plant
1	8482	EVERGREEN AV	Front	1	VACANT SITE	Plant
3	8614	EVERGREEN AV	Front	1	VACANT SITE	Plant
3	8621	EVERGREEN AV	Front	1	VACANT SITE	Plant
3	8623	EVERGREEN AV	Front	1	VACANT SITE	Plant
3	8641	EVERGREEN AV	Front	1	VACANT SITE	Plant
3	8648	EVERGREEN AV	Front	1	VACANT SITE	Plant
3	8676	EVERGREEN AV	Front	1	VACANT SITE	Plant
3	8677	EVERGREEN AV	Front	1	VACANT SITE	Plant

City of South Gate
Vacant Planting Sites - November 2007

DIST	HOUSE ADDRESS	SIDE	TREE	ON ADDRESS	COMMON NAME	MAINTENANCE
3	8680 EVERGREEN AV	Front	1		VACANT SITE	Plant
3	8684 EVERGREEN AV	Front	1		VACANT SITE	Plant
6	8901 X EVERGREEN AV	Front	1		VACANT SITE	Plant
6	8901 X EVERGREEN AV	Front	2		VACANT SITE	Plant
6	8928 EVERGREEN AV	Front	1		VACANT SITE	Plant
6	8946 EVERGREEN AV	Front	1		VACANT SITE	Plant
6	8947 EVERGREEN AV	Front	1		VACANT SITE	Plant
6	8950 EVERGREEN AV	Front	1		VACANT SITE	Plant
5	2600 FIRESTONE BL	Side	1	8900 X TOPE AV	VACANT SITE	Plant
5	2600 FIRESTONE BL	Side	2	8900 X TOPE AV	VACANT SITE	Plant
5	2701 FIRESTONE BL	Side	3	8800 X SANTA FE AV	VACANT SITE	Plant
5	2735 FIRESTONE BL	Front	5		VACANT SITE	Plant
6	3030 FIRESTONE BL	Side	1	8901 X CYPRESS AV	VACANT SITE	Plant
6	3030 FIRESTONE BL	Side	2	8901 X CYPRESS AV	VACANT SITE	Plant
6	3030 FIRESTONE BL	Side	3	8901 X CYPRESS AV	VACANT SITE	Plant
6	3050 FIRESTONE BL	Side	1	8900 X CYPRESS AV	VACANT SITE	Plant
3	3051 FIRESTONE BL	Side	1	8698 X CYPRESS AV	VACANT SITE	Plant
3	3051 FIRESTONE BL	Side	2	8698 X CYPRESS AV	VACANT SITE	Plant
3	3079 FIRESTONE BL	Side	1	8695 X GARDEN VIEW AV	VACANT SITE	Plant
6	3420 FIRESTONE BL	Side	1	8901 X VIRGINIA AV	VACANT SITE	Plant
6	3420 FIRESTONE BL	Side	2	8901 X VIRGINIA AV	VACANT SITE	Plant
3	3425 FIRESTONE BL	Side	1	8695 X VIRGINIA AV	VACANT SITE	Plant
3	3425 FIRESTONE BL	Side	2	8695 X VIRGINIA AV	VACANT SITE	Plant
4	3610 FIRESTONE BL	Front	1		VACANT SITE	Plant
4	3615 FIRESTONE BL	Side	1	8690 X SAN ANTONIO AV	VACANT SITE	Plant
4	3615 FIRESTONE BL	Side	2	8690 X SAN ANTONIO AV	VACANT SITE	Plant
4	3705 FIRESTONE BL	Front	3		VACANT SITE	Plant
4	3827 FIRESTONE BL	Front	4		VACANT SITE	Plant
7	4020 FIRESTONE BL	Side	1	8901 X SAN MIGUEL AV	VACANT SITE	Plant
7	4060 FIRESTONE BL	Side	1	8900 X SAN MIGUEL AV	VACANT SITE	Plant
4	4224 FIRESTONE BL	Front	1		VACANT SITE	Plant
7	4230 FIRESTONE BL	Side	1	8901 X MCNERNEY AV	VACANT SITE	Plant

City of South Gate

Vacant Planting Sites - November 2007

DIST	HOUSE ADDRESS	SIDE	TREE	ON ADDRESS	COMMON NAME	MAINTENANCE	
7	4300	FIRESTONE BL	Side	1	8900 X MCNERNEY AV	VACANT SITE	Plant
4	4301	FIRESTONE BL	Front	2		VACANT SITE	Plant
7	4424	FIRESTONE BL	Side	1	8901 X BRYSON AV	VACANT SITE	Plant
7	4574	FIRESTONE BL	Side	1	8901 X KAUFFMAN AV	VACANT SITE	Plant
7	4574	FIRESTONE BL	Side	2	8901 X KAUFFMAN AV	VACANT SITE	Plant
7	4704	FIRESTONE BL	Side	1	8900 X HILDRETH AV	VACANT SITE	Plant
7	4704	FIRESTONE BL	Side	2	8900 X HILDRETH AV	VACANT SITE	Plant
5	8901	FIRESTONE PLZ	Front	1		VACANT SITE	Plant
5	8906	FIRESTONE PLZ	Front	1		VACANT SITE	Plant
5	8915	FIRESTONE PLZ	Front	1		VACANT SITE	Plant
5	8918	FIRESTONE PLZ	Front	1		VACANT SITE	Plant
5	8923	FIRESTONE PLZ	Front	1		VACANT SITE	Plant
5	8926	FIRESTONE PLZ	Front	1		VACANT SITE	Plant
5	8932	FIRESTONE PLZ	Front	1		VACANT SITE	Plant
5	8933	FIRESTONE PLZ	Front	1		VACANT SITE	Plant
17	5709	FLORENCE AV	Front	1		VACANT SITE	Plant
17	5713	FLORENCE AV	Front	1		VACANT SITE	Plant
17	5720	FLORENCE AV	Front	2		VACANT SITE	Plant
17	5720	FLORENCE AV	Front	3		VACANT SITE	Plant
17	5720	FLORENCE AV	Side	1	5715 X CENTURY BL	VACANT SITE	Plant
17	5720	FLORENCE AV	Side	2	5715 X CENTURY BL	VACANT SITE	Plant
17	5720	FLORENCE AV	Side	3	5715 X CENTURY BL	VACANT SITE	Plant
17	5721	FLORENCE AV	Front	1		VACANT SITE	Plant
17	5737	FLORENCE AV	Front	1		VACANT SITE	Plant
17	5757	FLORENCE AV	Front	1		VACANT SITE	Plant
17	5783	FLORENCE AV	Side	2	12315 X CENTER ST	VACANT SITE	Plant
18	6031	FLORENCE AV	Front	1		VACANT SITE	Plant
18	6100	FLORENCE AV	Side	2	12400 X HOOVER AV	VACANT SITE	Plant
18	6106	FLORENCE AV	Front	1		VACANT SITE	Plant
18	6136	FLORENCE AV	Front	1		VACANT SITE	Plant
18	6150	FLORENCE AV	Front	1		VACANT SITE	Plant
18	6171	FLORENCE AV	Front	1		VACANT SITE	Plant

City of South Gate
Vacant Planting Sites - November 2007

DIST	HOUSE ADDRESS	SIDE	TREE	ON ADDRESS	COMMON NAME	MAINTENANCE
1	8101 GARDEN VIEW AV	Side	1	3080 X SANTA ANA ST	VACANT SITE	Plant
1	8105 GARDEN VIEW AV	Front	1		VACANT SITE	Plant
1	8108 GARDEN VIEW AV	Front	1		VACANT SITE	Plant
1	8114 GARDEN VIEW AV	Front	1		VACANT SITE	Plant
1	8118 GARDEN VIEW AV	Front	1		VACANT SITE	Plant
1	8124 GARDEN VIEW AV	Front	1		VACANT SITE	Plant
1	8148 GARDEN VIEW AV	Front	1		VACANT SITE	Plant
1	8159 GARDEN VIEW AV	Front	1		VACANT SITE	Plant
1	8166 GARDEN VIEW AV	Front	1		VACANT SITE	Plant
1	8169 GARDEN VIEW AV	Front	1		VACANT SITE	Plant
1	8170 GARDEN VIEW AV	Front	1		VACANT SITE	Plant
1	8173 GARDEN VIEW AV	Front	2		VACANT SITE	Plant
1	8174 GARDEN VIEW AV	Front	1		VACANT SITE	Plant
1	8178 GARDEN VIEW AV	Front	1		VACANT SITE	Plant
1	8184 GARDEN VIEW AV	Front	1		VACANT SITE	Plant
1	8185 GARDEN VIEW AV	Front	1		VACANT SITE	Plant
1	8412 GARDEN VIEW AV	Front	1		VACANT SITE	Plant
1	8418 GARDEN VIEW AV	Front	1		VACANT SITE	Plant
1	8421 GARDEN VIEW AV	Front	1		VACANT SITE	Plant
1	8429 GARDEN VIEW AV	Front	1		VACANT SITE	Plant
1	8430 GARDEN VIEW AV	Front	1		VACANT SITE	Plant
1	8434 GARDEN VIEW AV	Front	1		VACANT SITE	Plant
1	8435 GARDEN VIEW AV	Front	1		VACANT SITE	Plant
1	8438 GARDEN VIEW AV	Front	1		VACANT SITE	Plant
1	8443 GARDEN VIEW AV	Front	1		VACANT SITE	Plant
1	8447 GARDEN VIEW AV	Front	1		VACANT SITE	Plant
1	8452 GARDEN VIEW AV	Front	1		VACANT SITE	Plant
1	8457 GARDEN VIEW AV	Front	1		VACANT SITE	Plant
1	8458 GARDEN VIEW AV	Front	1		VACANT SITE	Plant
1	8462 GARDEN VIEW AV	Front	1		VACANT SITE	Plant
1	8466 GARDEN VIEW AV	Front	1		VACANT SITE	Plant
1	8473 GARDEN VIEW AV	Front	1		VACANT SITE	Plant

City of South Gate

Vacant Planting Sites - November 2007

DIST	HOUSE ADDRESS	SIDE	TREE	ON ADDRESS	COMMON NAME	MAINTENANCE	
1	8480	GARDEN VIEW AV	Front	1	VACANT SITE	Plant	
3	8659	GARDEN VIEW AV	Front	1	VACANT SITE	Plant	
3	8661	GARDEN VIEW AV	Front	1	VACANT SITE	Plant	
3	8676	GARDEN VIEW AV	Front	1	VACANT SITE	Plant	
3	8684	GARDEN VIEW AV	Front	1	VACANT SITE	Plant	
3	8693	GARDEN VIEW AV	Front	1	VACANT SITE	Plant	
6	8925	GARDEN VIEW AV	Front	1	VACANT SITE	Plant	
6	8940	GARDEN VIEW AV	Front	1	VACANT SITE	Plant	
6	8953	GARDEN VIEW AV	Front	1	VACANT SITE	Plant	
6	8956	GARDEN VIEW AV	Front	1	VACANT SITE	Plant	
6	8964	GARDEN VIEW AV	Front	1	VACANT SITE	Plant	
6	8978	GARDEN VIEW AV	Front	1	VACANT SITE	Plant	
6	9202	GARDEN VIEW AV	Side	2	3100 X SOUTHERN AV	VACANT SITE	Plant
8	9336	GARDEN VIEW AV	Front	1	VACANT SITE	Plant	
8	9425 X	GARDEN VIEW AV	Front	2	VACANT SITE	Plant	
18	5956	GARDENDALE ST	Front	1	VACANT SITE	Plant	
18	5976	GARDENDALE ST	Front	1	VACANT SITE	Plant	
18	5992	GARDENDALE ST	Side	2	11701 X ARIZONA AV	VACANT SITE	Plant
18	6000	GARDENDALE ST	Front	1	VACANT SITE	Plant	
18	6020	GARDENDALE ST	Front	1	VACANT SITE	Plant	
18	6060	GARDENDALE ST	Front	1	VACANT SITE	Plant	
18	6150	GARDENDALE ST	Front	1	VACANT SITE	Plant	
15	9301	GARFIELD AV	Front	1	VACANT SITE	Plant	
15	9301	GARFIELD AV	Front	2	VACANT SITE	Plant	
15	9301	GARFIELD AV	Front	3	VACANT SITE	Plant	
15	9301	GARFIELD AV	Front	4	VACANT SITE	Plant	
15	9301	GARFIELD AV	Front	5	VACANT SITE	Plant	
15	9302	GARFIELD AV	Front	2	VACANT SITE	Plant	
15	9302	GARFIELD AV	Front	3	VACANT SITE	Plant	
15	9302	GARFIELD AV	Front	4	VACANT SITE	Plant	
15	9302	GARFIELD AV	Front	5	VACANT SITE	Plant	
15	9302	GARFIELD AV	Front	9	VACANT SITE	Plant	

City of South Gate
Vacant Planting Sites - November 2007

DIST	HOUSE ADDRESS	SIDE	TREE	ON ADDRESS	COMMON NAME	MAINTENANCE
16	9501 X GARFIELD AV	Front	17		VACANT SITE	Plant
16	9501 X GARFIELD AV	Front	18		VACANT SITE	Plant
16	10201 GARFIELD AV	Front	1		VACANT SITE	Plant
16	10206 GARFIELD AV	Front	1		VACANT SITE	Plant
16	10219 GARFIELD AV	Front	1		VACANT SITE	Plant
16	10225 GARFIELD AV	Front	1		VACANT SITE	Plant
16	10226 GARFIELD AV	Front	1		VACANT SITE	Plant
16	10232 GARFIELD AV	Front	1		VACANT SITE	Plant
16	10236 GARFIELD AV	Front	1		VACANT SITE	Plant
16	10239 GARFIELD AV	Front	1		VACANT SITE	Plant
16	10242 GARFIELD AV	Front	1		VACANT SITE	Plant
16	10245 GARFIELD AV	Front	1		VACANT SITE	Plant
16	10302 GARFIELD AV	Front	1		VACANT SITE	Plant
16	10309 GARFIELD AV	Front	1		VACANT SITE	Plant
16	10312 GARFIELD AV	Front	1		VACANT SITE	Plant
16	10328 GARFIELD AV	Front	1		VACANT SITE	Plant
16	10328 GARFIELD AV	Front	2		VACANT SITE	Plant
16	10332 GARFIELD AV	Front	1		VACANT SITE	Plant
16	10332 GARFIELD AV	Front	2		VACANT SITE	Plant
16	10341 GARFIELD AV	Side	1	5765 X BURNTWOOD ST	VACANT SITE	Plant
16	10401 GARFIELD AV	Front	1		VACANT SITE	Plant
16	10401 GARFIELD AV	Side	2	5760 X BURNTWOOD ST	VACANT SITE	Plant
16	10404 GARFIELD AV	Front	1		VACANT SITE	Plant
16	10409 GARFIELD AV	Front	1		VACANT SITE	Plant
16	10420 GARFIELD AV	Front	1		VACANT SITE	Plant
16	10426 GARFIELD AV	Front	1		VACANT SITE	Plant
16	10430 GARFIELD AV	Front	1		VACANT SITE	Plant
16	10435 GARFIELD AV	Front	1		VACANT SITE	Plant
16	10507 GARFIELD AV	Front	1		VACANT SITE	Plant
16	10512 GARFIELD AV	Front	1		VACANT SITE	Plant
16	10516 GARFIELD AV	Front	1		VACANT SITE	Plant
16	10517 GARFIELD AV	Front	1		VACANT SITE	Plant

City of South Gate

Vacant Planting Sites - November 2007

DIST	HOUSE ADDRESS	SIDE	TREE	ON ADDRESS	COMMON NAME	MAINTENANCE	
16	10521	GARFIELD AV	Front	1		VACANT SITE	Plant
16	10522	GARFIELD AV	Front	1		VACANT SITE	Plant
16	10528	GARFIELD AV	Front	1		VACANT SITE	Plant
16	10538	GARFIELD AV	Front	1		VACANT SITE	Plant
16	10543	GARFIELD AV	Front	1		VACANT SITE	Plant
16	10544	GARFIELD AV	Side	1	5801 X GLADY ST	VACANT SITE	Plant
16	10547	GARFIELD AV	Side	1	5715 X GLADY ST	VACANT SITE	Plant
16	11220	GARFIELD AV	Front	2		VACANT SITE	Plant
16	11220	GARFIELD AV	Front	9		VACANT SITE	Plant
17	11301	GARFIELD AV	Side	1	5670 X GARDENDALE ST	VACANT SITE	Plant
17	11301	GARFIELD AV	Side	2	5670 X GARDENDALE ST	VACANT SITE	Plant
17	11321	GARFIELD AV	Side	1	5665 X MONROE AV	VACANT SITE	Plant
17	11606	GARFIELD AV	Front	1		VACANT SITE	Plant
17	11612	GARFIELD AV	Front	1		VACANT SITE	Plant
17	11624	GARFIELD AV	Side	3	5701 X JEFFERSON AV	VACANT SITE	Plant
17	11725	GARFIELD AV	Side	2	5675 X MCKINLEY AV	VACANT SITE	Plant
17	11801	GARFIELD AV	Side	1	5670 X MCKINLEY AV	VACANT SITE	Plant
17	11900	GARFIELD AV	Side	2	5700 X WILSON AV	VACANT SITE	Plant
17	12311	GARFIELD AV	Side	2	5665 X CENTURY BL	VACANT SITE	Plant
16	5712	GLADY ST	Front	1		VACANT SITE	Plant
16	5716	GLADY ST	Side	1	10601 X GARFIELD AV	VACANT SITE	Plant
16	5800	GLADY ST	Front	1		VACANT SITE	Plant
16	5812	GLADY ST	Front	1		VACANT SITE	Plant
16	5816	GLADY ST	Front	1		VACANT SITE	Plant
16	5817	GLADY ST	Front	1		VACANT SITE	Plant
16	5822	GLADY ST	Front	1		VACANT SITE	Plant
16	5832	GLADY ST	Front	1		VACANT SITE	Plant
16	5833	GLADY ST	Front	1		VACANT SITE	Plant
16	5836	GLADY ST	Front	1		VACANT SITE	Plant
5	2406	GLENWOOD PL	Front	1		VACANT SITE	Plant
5	2422	GLENWOOD PL	Front	1		VACANT SITE	Plant
5	2506	GLENWOOD PL	Front	1		VACANT SITE	Plant

City of South Gate
Vacant Planting Sites - November 2007

DIST	HOUSE ADDRESS	SIDE	TREE	ON ADDRESS	COMMON NAME	MAINTENANCE
5	2540 GLENWOOD PL	Front	1		VACANT SITE	Plant
5	2715 GLENWOOD PL	Front	1		VACANT SITE	Plant
5	2734 GLENWOOD PL	Front	1		VACANT SITE	Plant
5	2739 GLENWOOD PL	Front	1		VACANT SITE	Plant
5	2746 GLENWOOD PL	Front	1		VACANT SITE	Plant
5	2749 GLENWOOD PL	Front	1		VACANT SITE	Plant
5	2753 GLENWOOD PL	Front	1		VACANT SITE	Plant
5	2757 GLENWOOD PL	Front	1		VACANT SITE	Plant
5	2758 GLENWOOD PL	Front	1		VACANT SITE	Plant
5	2783 GLENWOOD PL	Front	1		VACANT SITE	Plant
5	2791 GLENWOOD PL	Front	2		VACANT SITE	Plant
5	2799 GLENWOOD PL	Front	1		VACANT SITE	Plant
5	2803 GLENWOOD PL	Front	1		VACANT SITE	Plant
6	3021 GLENWOOD PL	Front	1		VACANT SITE	Plant
17	5775 HARDING AV	Front	1		VACANT SITE	Plant
17	5781 HARDING AV	Front	1		VACANT SITE	Plant
17	5790 HARDING AV	Front	1		VACANT SITE	Plant
17	5791 HARDING AV	Front	1		VACANT SITE	Plant
18	6011 HARDING AV	Front	1		VACANT SITE	Plant
18	6041 HARDING AV	Front	1		VACANT SITE	Plant
18	6054 HARDING AV	Front	1		VACANT SITE	Plant
18	6064 HARDING AV	Front	1		VACANT SITE	Plant
18	6070 HARDING AV	Front	1		VACANT SITE	Plant
18	6100 HARDING AV	Side	1	12200 X HOOVER AV	VACANT SITE	Plant
18	6107 HARDING AV	Front	1		VACANT SITE	Plant
18	6136 HARDING AV	Front	1		VACANT SITE	Plant
18	6150 HARDING AV	Front	1		VACANT SITE	Plant
7	8913 HILDRETH AV	Front	1		VACANT SITE	Plant
7	8916 HILDRETH AV	Front	1		VACANT SITE	Plant
7	8925 HILDRETH AV	Front	1		VACANT SITE	Plant
7	8939 HILDRETH AV	Front	1		VACANT SITE	Plant
7	8945 HILDRETH AV	Front	1		VACANT SITE	Plant

City of South Gate

Vacant Planting Sites - November 2007

DIST	HOUSE ADDRESS	SIDE	TREE	ON ADDRESS	COMMON NAME	MAINTENANCE	
7	8946	HILDRETH AV	Front	1	VACANT SITE	Plant	
7	8949	HILDRETH AV	Front	1	VACANT SITE	Plant	
7	8974	HILDRETH AV	Front	1	VACANT SITE	Plant	
7	8980	HILDRETH AV	Front	1	VACANT SITE	Plant	
7	8981	HILDRETH AV	Front	1	VACANT SITE	Plant	
7	8992	HILDRETH AV	Front	1	VACANT SITE	Plant	
10	9215	HILDRETH AV	Front	1	VACANT SITE	Plant	
10	9223	HILDRETH AV	Front	1	VACANT SITE	Plant	
10	9229	HILDRETH AV	Front	1	VACANT SITE	Plant	
10	9233	HILDRETH AV	Front	1	VACANT SITE	Plant	
10	9305	HILDRETH AV	Front	1	VACANT SITE	Plant	
10	9323	HILDRETH AV	Front	1	VACANT SITE	Plant	
10	9415	HILDRETH AV	Side	2	4675 X DUANE WY	VACANT SITE	Plant
10	9539	HILDRETH AV	Front	1	VACANT SITE	Plant	
10	9707	HILDRETH AV	Side	1	4680 X MISSOURI AV	VACANT SITE	Plant
10	9723	HILDRETH AV	Front	1	VACANT SITE	Plant	
10	9803	HILDRETH AV	Front	1	VACANT SITE	Plant	
14	9925	HILDRETH AV	Front	1	VACANT SITE	Plant	
14	10001	HILDRETH AV	Front	1	VACANT SITE	Plant	
14	10005	HILDRETH AV	Front	1	VACANT SITE	Plant	
14	10009	HILDRETH AV	Front	1	VACANT SITE	Plant	
14	10020	HILDRETH AV	Front	1	VACANT SITE	Plant	
14	10024	HILDRETH AV	Front	1	VACANT SITE	Plant	
14	10109	HILDRETH AV	Front	1	VACANT SITE	Plant	
14	10128	HILDRETH AV	Front	1	VACANT SITE	Plant	
14	10135	HILDRETH AV	Side	2	4665 X MICHIGAN AV	VACANT SITE	Plant
14	10135	HILDRETH AV	Side	3	4665 X MICHIGAN AV	VACANT SITE	Plant
14	10206	HILDRETH AV	Side	1	4700 X MICHIGAN AV	VACANT SITE	Plant
14	10206	HILDRETH AV	Side	2	4700 X MICHIGAN AV	VACANT SITE	Plant
14	10207	HILDRETH AV	Side	2	4660 X MICHIGAN AV	VACANT SITE	Plant
14	10210	HILDRETH AV	Front	1	VACANT SITE	Plant	
14	10227	HILDRETH AV	Front	1	VACANT SITE	Plant	

City of South Gate
Vacant Planting Sites - November 2007

DIST	HOUSE ADDRESS	SIDE	TREE	ON ADDRESS	COMMON NAME	MAINTENANCE	
14	10231	HILDRETH AV	Front	1		VACANT SITE	Plant
14	10238	HILDRETH AV	Front	1		VACANT SITE	Plant
14	10301	HILDRETH AV	Front	1		VACANT SITE	Plant
14	10346	HILDRETH AV	Side	2	4701 X TENAYA AV	VACANT SITE	Plant
14	10411	HILDRETH AV	Front	1		VACANT SITE	Plant
14	10414	HILDRETH AV	Front	1		VACANT SITE	Plant
14	10415	HILDRETH AV	Front	1		VACANT SITE	Plant
14	10418	HILDRETH AV	Front	1		VACANT SITE	Plant
14	10423	HILDRETH AV	Front	1		VACANT SITE	Plant
14	10501	HILDRETH AV	Front	1		VACANT SITE	Plant
14	10505	HILDRETH AV	Front	1		VACANT SITE	Plant
14	10517	HILDRETH AV	Front	1		VACANT SITE	Plant
14	10529	HILDRETH AV	Front	1		VACANT SITE	Plant
17	7300	HOWERY ST	Front	1		VACANT SITE	Plant
17	7317	HOWERY ST	Side	1	13680 X FLEET DR	VACANT SITE	Plant
17	7327	HOWERY ST	Front	1		VACANT SITE	Plant
17	7333	HOWERY ST	Front	1		VACANT SITE	Plant
17	7347	HOWERY ST	Front	1		VACANT SITE	Plant
17	7400	HOWERY ST	Front	1		VACANT SITE	Plant
17	7404	HOWERY ST	Front	1		VACANT SITE	Plant
17	7441	HOWERY ST	Side	1	13674 X CLOVERLAWN DR	VACANT SITE	Plant
7	8913	HUNT AV	Front	1		VACANT SITE	Plant
7	8930	HUNT AV	Front	1		VACANT SITE	Plant
7	8936	HUNT AV	Front	1		VACANT SITE	Plant
7	8942	HUNT AV	Front	1		VACANT SITE	Plant
7	8946	HUNT AV	Front	1		VACANT SITE	Plant
7	8950	HUNT AV	Front	1		VACANT SITE	Plant
7	8954	HUNT AV	Front	1		VACANT SITE	Plant
7	8973	HUNT AV	Front	1		VACANT SITE	Plant
7	8979	HUNT AV	Front	1		VACANT SITE	Plant
10	9205	HUNT AV	Front	1		VACANT SITE	Plant
7	9206	HUNT AV	Side	2	4500 X SOUTHERN AV	VACANT SITE	Plant

City of South Gate

Vacant Planting Sites - November 2007

DIST	HOUSE ADDRESS	SIDE	TREE	ON ADDRESS	COMMON NAME	MAINTENANCE
7	9206 HUNT AV	Side	3	4500 X SOUTHERN AV	VACANT SITE	Plant
10	9211 HUNT AV	Front	1		VACANT SITE	Plant
10	9222 HUNT AV	Front	1		VACANT SITE	Plant
10	9227 HUNT AV	Front	1		VACANT SITE	Plant
10	9231 HUNT AV	Front	1		VACANT SITE	Plant
10	9330 HUNT AV	Front	1		VACANT SITE	Plant
10	9335 HUNT AV	Front	1		VACANT SITE	Plant
10	9403 HUNT AV	Front	1		VACANT SITE	Plant
10	9418 HUNT AV	Side	1	4501 X DUANE WY	VACANT SITE	Plant
10	9418 HUNT AV	Side	2	4501 X DUANE WY	VACANT SITE	Plant
10	9508 HUNT AV	Front	1		VACANT SITE	Plant
10	9508 HUNT AV	Side	1	4500 X DUANE WY	VACANT SITE	Plant
10	9508 HUNT AV	Side	2	4500 X DUANE WY	VACANT SITE	Plant
10	9526 HUNT AV	Front	1		VACANT SITE	Plant
10	9541 HUNT AV	Front	1		VACANT SITE	Plant
10	9542 HUNT AV	Front	1		VACANT SITE	Plant
10	9606 HUNT AV	Front	1		VACANT SITE	Plant
10	9611 HUNT AV	Front	2		VACANT SITE	Plant
10	9636 HUNT AV	Front	1		VACANT SITE	Plant
10	9642 HUNT AV	Front	1		VACANT SITE	Plant
10	9701 X HUNT AV	Front	7		VACANT SITE	Plant
10	9708 HUNT AV	Side	1	4500 X MISSOURI AV	VACANT SITE	Plant
10	9714 HUNT AV	Front	1		VACANT SITE	Plant
10	9726 HUNT AV	Front	1		VACANT SITE	Plant
10	9814 HUNT AV	Front	1		VACANT SITE	Plant
14	9924 HUNT AV	Front	1		VACANT SITE	Plant
14	9932 HUNT AV	Front	1		VACANT SITE	Plant
14	10004 HUNT AV	Front	1		VACANT SITE	Plant
14	10007 HUNT AV	Front	1		VACANT SITE	Plant
14	10012 HUNT AV	Front	1		VACANT SITE	Plant
14	10125 HUNT AV	Front	1		VACANT SITE	Plant
14	10131 HUNT AV	Front	1		VACANT SITE	Plant

City of South Gate
Vacant Planting Sites - November 2007

DIST	HOUSE ADDRESS	SIDE	TREE	ON ADDRESS	COMMON NAME	MAINTENANCE
14	10136 HUNT AV	Front	1		VACANT SITE	Plant
14	10141 HUNT AV	Side	1	4465 X MICHIGAN AV	VACANT SITE	Plant
14	10221 HUNT AV	Front	1		VACANT SITE	Plant
14	10225 HUNT AV	Front	1		VACANT SITE	Plant
14	10236 HUNT AV	Front	1		VACANT SITE	Plant
14	10241 HUNT AV	Front	1		VACANT SITE	Plant
14	10242 HUNT AV	Front	1		VACANT SITE	Plant
14	10247 HUNT AV	Front	1		VACANT SITE	Plant
14	10301 HUNT AV	Front	1		VACANT SITE	Plant
14	10319 HUNT AV	Front	1		VACANT SITE	Plant
14	10320 HUNT AV	Front	1		VACANT SITE	Plant
14	10331 HUNT AV	Front	1		VACANT SITE	Plant
14	10337 HUNT AV	Front	1		VACANT SITE	Plant
14	10341 HUNT AV	Front	1		VACANT SITE	Plant
14	10343 HUNT AV	Side	1	4465 X TENAYA AV	VACANT SITE	Plant
14	10343 HUNT AV	Side	2	4465 X TENAYA AV	VACANT SITE	Plant
14	10347 HUNT AV	Front	1		VACANT SITE	Plant
14	10406 HUNT AV	Side	1	4500 X TENAYA AV	VACANT SITE	Plant
14	10406 HUNT AV	Side	2	4500 X TENAYA AV	VACANT SITE	Plant
14	10418 HUNT AV	Front	1		VACANT SITE	Plant
14	10508 HUNT AV	Front	1		VACANT SITE	Plant
14	10516 HUNT AV	Front	1		VACANT SITE	Plant
17	11350 IDAHO AV	Front	1		VACANT SITE	Plant
17	11357 IDAHO AV	Front	1		VACANT SITE	Plant
17	11391 IDAHO AV	Side	2	5455 X MONROE AV	VACANT SITE	Plant
17	11611 IDAHO AV	Front	1		VACANT SITE	Plant
17	11614 IDAHO AV	Front	1		VACANT SITE	Plant
5	2462 ILLINOIS AV	Front	1		VACANT SITE	Plant
5	2463 ILLINOIS AV	Front	1		VACANT SITE	Plant
5	2470 ILLINOIS AV	Front	1		VACANT SITE	Plant
5	2491 ILLINOIS AV	Front	1		VACANT SITE	Plant
5	2500 ILLINOIS AV	Front	1		VACANT SITE	Plant

City of South Gate

Vacant Planting Sites - November 2007

DIST	HOUSE ADDRESS	SIDE	TREE	ON ADDRESS	COMMON NAME	MAINTENANCE
5	2501	ILLINOIS AV	Front	1	VACANT SITE	Plant
5	2505	ILLINOIS AV	Front	1	VACANT SITE	Plant
5	2509	ILLINOIS AV	Front	1	VACANT SITE	Plant
5	2515	ILLINOIS AV	Front	1	VACANT SITE	Plant
5	2517	ILLINOIS AV	Front	1	VACANT SITE	Plant
5	2527	ILLINOIS AV	Front	1	VACANT SITE	Plant
5	2532	ILLINOIS AV	Front	1	VACANT SITE	Plant
5	2585	ILLINOIS AV	Front	1	VACANT SITE	Plant
5	2619	ILLINOIS AV	Front	1	VACANT SITE	Plant
5	2631	ILLINOIS AV	Front	1	VACANT SITE	Plant
5	2716	ILLINOIS AV	Front	1	VACANT SITE	Plant
5	2736	ILLINOIS AV	Front	1	VACANT SITE	Plant
5	2812	ILLINOIS AV	Front	1	VACANT SITE	Plant
5	2928	ILLINOIS AV	Front	1	VACANT SITE	Plant
8	3039	ILLINOIS AV	Side	1	9335 X GARDEN VIEW AV	Plant
8	3139	ILLINOIS AV	Front	1	VACANT SITE	Plant
16	5811	IMPERIAL HWY	Front	1	VACANT SITE	Plant
16	5833	IMPERIAL HWY	Front	1	VACANT SITE	Plant
16	5839	IMPERIAL HWY	Front	1	VACANT SITE	Plant
16	5845	IMPERIAL HWY	Side	1	10855 X CASSINA AV	Plant
16	5903	IMPERIAL HWY	Side	1	10850 X AMERY AV	Plant
16	5903	IMPERIAL HWY	Side	2	10850 X AMERY AV	Plant
1	2735	INDEPENDENCE AV	Front	1	VACANT SITE	Plant
1	2813	INDEPENDENCE AV	Front	1	VACANT SITE	Plant
1	2825	INDEPENDENCE AV	Front	1	VACANT SITE	Plant
1	2825	INDEPENDENCE AV	Side	1	8481 X MOUNTAIN VIEW AV	Plant
1	2977	INDEPENDENCE AV	Front	2	VACANT SITE	Plant
1	3065	INDEPENDENCE AV	Front	1	VACANT SITE	Plant
1	3077	INDEPENDENCE AV	Front	1	VACANT SITE	Plant
1	3077	INDEPENDENCE AV	Front	2	VACANT SITE	Plant
1	3077	INDEPENDENCE AV	Side	1	8485 X GARDEN VIEW AV	Plant
1	3151	INDEPENDENCE AV	Front	4	VACANT SITE	Plant

City of South Gate
Vacant Planting Sites - November 2007

DIST	HOUSE ADDRESS	SIDE	TREE	ON ADDRESS	COMMON NAME	MAINTENANCE
1	3151 INDEPENDENCE AV	Side	1	8480 X SOUTH GATE AV	VACANT SITE	Plant
1	3169 INDEPENDENCE AV	Front	1		VACANT SITE	Plant
1	3205 INDEPENDENCE AV	Front	1		VACANT SITE	Plant
1	3205 INDEPENDENCE AV	Side	2	8470 X MADISON AV	VACANT SITE	Plant
1	3369 INDEPENDENCE AV	Front	1		VACANT SITE	Plant
1	3423 INDEPENDENCE AV	Front	1		VACANT SITE	Plant
2	3601 INDEPENDENCE AV	Side	1	8480 X SAN ANTONIO AV	VACANT SITE	Plant
2	3601 INDEPENDENCE AV	Side	2	8480 X SAN ANTONIO AV	VACANT SITE	Plant
2	3609 INDEPENDENCE AV	Front	1		VACANT SITE	Plant
2	3613 INDEPENDENCE AV	Front	1		VACANT SITE	Plant
2	3703 INDEPENDENCE AV	Front	1		VACANT SITE	Plant
2	3711 INDEPENDENCE AV	Front	1		VACANT SITE	Plant
2	3713 INDEPENDENCE AV	Front	1		VACANT SITE	Plant
2	3717 INDEPENDENCE AV	Front	1		VACANT SITE	Plant
2	3805 INDEPENDENCE AV	Front	1		VACANT SITE	Plant
2	3817 INDEPENDENCE AV	Front	1		VACANT SITE	Plant
2	3827 INDEPENDENCE AV	Front	1		VACANT SITE	Plant
2	4013 INDEPENDENCE AV	Front	1		VACANT SITE	Plant
2	4017 INDEPENDENCE AV	Front	1		VACANT SITE	Plant
2	4061 INDEPENDENCE AV	Front	1		VACANT SITE	Plant
2	4065 INDEPENDENCE AV	Front	1		VACANT SITE	Plant
2	4069 INDEPENDENCE AV	Front	1		VACANT SITE	Plant
2	4103 INDEPENDENCE AV	Side	1	8480 X SAN VICENTE AV	VACANT SITE	Plant
2	4115 INDEPENDENCE AV	Front	1		VACANT SITE	Plant
2	4119 INDEPENDENCE AV	Front	1		VACANT SITE	Plant
2	4125 INDEPENDENCE AV	Front	1		VACANT SITE	Plant
5	2504 INDIANA AV	Front	1		VACANT SITE	Plant
5	2518 INDIANA AV	Front	1		VACANT SITE	Plant
5	2536 INDIANA AV	Front	1		VACANT SITE	Plant
5	2568 INDIANA AV	Front	1		VACANT SITE	Plant
5	2569 INDIANA AV	Front	1		VACANT SITE	Plant
5	2573 INDIANA AV	Front	1		VACANT SITE	Plant

City of South Gate

Vacant Planting Sites - November 2007

DIST	HOUSE ADDRESS	SIDE	TREE	ON ADDRESS	COMMON NAME	MAINTENANCE
5	2611 INDIANA AV	Side	1	9736 X TRUBA AV	VACANT SITE	Plant
5	2611 INDIANA AV	Side	2	9736 X TRUBA AV	VACANT SITE	Plant
5	2627 INDIANA AV	Front	1		VACANT SITE	Plant
5	2644 INDIANA AV	Front	1		VACANT SITE	Plant
5	2708 INDIANA AV	Front	1		VACANT SITE	Plant
5	2713 INDIANA AV	Front	1		VACANT SITE	Plant
5	2728 INDIANA AV	Front	1		VACANT SITE	Plant
5	2736 INDIANA AV	Front	1		VACANT SITE	Plant
5	2741 INDIANA AV	Front	1		VACANT SITE	Plant
5	2811 INDIANA AV	Front	1		VACANT SITE	Plant
5	2814 INDIANA AV	Front	2		VACANT SITE	Plant
5	2834 INDIANA AV	Front	1		VACANT SITE	Plant
5	2841 INDIANA AV	Front	1		VACANT SITE	Plant
5	2907 INDIANA AV	Side	1	9730 X STANFORD AV	VACANT SITE	Plant
5	2907 INDIANA AV	Side	2	9730 X STANFORD AV	VACANT SITE	Plant
5	2907 INDIANA AV	Side	3	9730 X STANFORD AV	VACANT SITE	Plant
5	2923 INDIANA AV	Front	1		VACANT SITE	Plant
5	2926 INDIANA AV	Front	1		VACANT SITE	Plant
5	2927 INDIANA AV	Front	1		VACANT SITE	Plant
5	2935 INDIANA AV	Front	1		VACANT SITE	Plant
5	2941 INDIANA AV	Front	1		VACANT SITE	Plant
5	3011 INDIANA AV	Front	1		VACANT SITE	Plant
18	11810 X INDUSTRIAL AV	Front	1		VACANT SITE	Plant
18	11810 X INDUSTRIAL AV	Front	2		VACANT SITE	Plant
18	12025 INDUSTRIAL AV	Side	1	5825 X MAIN ST	VACANT SITE	Plant
18	12025 INDUSTRIAL AV	Side	3	5825 X MAIN ST	VACANT SITE	Plant
5	2420 IOWA AV	Front	1		VACANT SITE	Plant
5	2435 IOWA AV	Front	1		VACANT SITE	Plant
5	2462 IOWA AV	Front	1		VACANT SITE	Plant
5	2471 IOWA AV	Front	1		VACANT SITE	Plant
5	2500 IOWA AV	Front	1		VACANT SITE	Plant
5	2513 IOWA AV	Front	1		VACANT SITE	Plant

City of South Gate
Vacant Planting Sites - November 2007

DIST	HOUSE ADDRESS	SIDE	TREE	ON ADDRESS	COMMON NAME	MAINTENANCE
5	2515 X IOWA AV	Front	1		VACANT SITE	Plant
5	2527 IOWA AV	Front	1		VACANT SITE	Plant
5	2545 IOWA AV	Front	1		VACANT SITE	Plant
5	2552 IOWA AV	Front	1		VACANT SITE	Plant
5	2584 IOWA AV	Side	2	9301 X TRUBA AV	VACANT SITE	Plant
5	2606 IOWA AV	Side	1	9300 X TRUBA AV	VACANT SITE	Plant
5	2615 X IOWA AV	Front	1		VACANT SITE	Plant
5	2638 IOWA AV	Front	1		VACANT SITE	Plant
5	2647 IOWA AV	Front	1		VACANT SITE	Plant
5	2700 IOWA AV	Front	1		VACANT SITE	Plant
5	2729 IOWA AV	Front	1		VACANT SITE	Plant
5	2833 IOWA AV	Front	1		VACANT SITE	Plant
5	2906 IOWA AV	Side	1	9300 X STANFORD AV	VACANT SITE	Plant
5	2914 IOWA AV	Front	1		VACANT SITE	Plant
5	2917 IOWA AV	Front	1		VACANT SITE	Plant
5	2928 IOWA AV	Front	1		VACANT SITE	Plant
8	3047 IOWA AV	Front	1		VACANT SITE	Plant
8	3052 IOWA AV	Front	1		VACANT SITE	Plant
8	3061 IOWA AV	Side	1	9225 X GARDEN VIEW AV	VACANT SITE	Plant
8	3123 IOWA AV	Front	1		VACANT SITE	Plant
8	3155 X IOWA AV	Front	1		VACANT SITE	Plant
8	3155 X IOWA AV	Front	2		VACANT SITE	Plant
14	10132 JACKSON AV	Side	2	4745 X MICHIGAN AV	VACANT SITE	Plant
14	10135 JACKSON AV	Side	2	4725 X MICHIGAN AV	VACANT SITE	Plant
14	10301 JACKSON AV	Front	1		VACANT SITE	Plant
14	10305 JACKSON AV	Front	1		VACANT SITE	Plant
14	10346 JACKSON AV	Side	3	4745 X TENAYA AV	VACANT SITE	Plant
14	10406 JACKSON AV	Side	3	4740 X TENAYA AV	VACANT SITE	Plant
14	10407 JACKSON AV	Side	1	4730 X TENAYA AV	VACANT SITE	Plant
14	10524 JACKSON AV	Front	1		VACANT SITE	Plant
5	2504 KANSAS AV	Front	1		VACANT SITE	Plant
5	2505 KANSAS AV	Front	1		VACANT SITE	Plant

City of South Gate

Vacant Planting Sites - November 2007

DIST	HOUSE ADDRESS	SIDE	TREE	ON ADDRESS	COMMON NAME	MAINTENANCE
5	2511 KANSAS AV	Front	1		VACANT SITE	Plant
5	2523 KANSAS AV	Front	1		VACANT SITE	Plant
5	2524 KANSAS AV	Front	1		VACANT SITE	Plant
5	2544 KANSAS AV	Front	1		VACANT SITE	Plant
5	2610 KANSAS AV	Front	1		VACANT SITE	Plant
5	2714 KANSAS AV	Front	1		VACANT SITE	Plant
5	2715 KANSAS AV	Front	1		VACANT SITE	Plant
5	2811 KANSAS AV	Front	1		VACANT SITE	Plant
5	2815 KANSAS AV	Front	1		VACANT SITE	Plant
5	2828 KANSAS AV	Front	1		VACANT SITE	Plant
5	2905 KANSAS AV	Side	1	9530 X STANFORD AV	VACANT SITE	Plant
5	2910 KANSAS AV	Front	3		VACANT SITE	Plant
5	2934 KANSAS AV	Front	1		VACANT SITE	Plant
5	2947 KANSAS AV	Front	1		VACANT SITE	Plant
5	2964 KANSAS AV	Front	1		VACANT SITE	Plant
8	3163 KANSAS AV	Front	1		VACANT SITE	Plant
8	3167 KANSAS AV	Front	1		VACANT SITE	Plant
15	9215 KARMONT AV	Front	1		VACANT SITE	Plant
15	9218 KARMONT AV	Front	1		VACANT SITE	Plant
15	9218 KARMONT AV	Side	2	6001 X DE PALMA ST	VACANT SITE	Plant
15	9219 KARMONT AV	Front	1		VACANT SITE	Plant
15	9229 KARMONT AV	Front	1		VACANT SITE	Plant
15	9306 KARMONT AV	Front	1		VACANT SITE	Plant
16	10209 KARMONT AV	Front	1		VACANT SITE	Plant
16	10223 KARMONT AV	Front	1		VACANT SITE	Plant
16	10233 KARMONT AV	Front	1		VACANT SITE	Plant
16	10253 KARMONT AV	Front	1		VACANT SITE	Plant
16	10320 KARMONT AV	Front	1		VACANT SITE	Plant
16	10321 KARMONT AV	Front	1		VACANT SITE	Plant
16	10332 KARMONT AV	Front	1		VACANT SITE	Plant
16	10337 KARMONT AV	Front	1		VACANT SITE	Plant
16	10407 KARMONT AV	Front	1		VACANT SITE	Plant

City of South Gate
Vacant Planting Sites - November 2007

DIST	HOUSE ADDRESS	SIDE	TREE	ON ADDRESS	COMMON NAME	MAINTENANCE
16	10427	KARMONT AV	Front	1	VACANT SITE	Plant
16	10507	KARMONT AV	Front	1	VACANT SITE	Plant
16	10511	KARMONT AV	Front	1	VACANT SITE	Plant
16	10521	KARMONT AV	Front	1	VACANT SITE	Plant
16	10536	KARMONT AV	Front	1	VACANT SITE	Plant
16	10537	KARMONT AV	Front	1	VACANT SITE	Plant
7	8912	KAUFFMAN AV	Front	1	VACANT SITE	Plant
7	8921	KAUFFMAN AV	Front	1	VACANT SITE	Plant
7	8930	KAUFFMAN AV	Front	1	VACANT SITE	Plant
7	8937	KAUFFMAN AV	Front	1	VACANT SITE	Plant
7	8943	KAUFFMAN AV	Front	1	VACANT SITE	Plant
7	8944	KAUFFMAN AV	Front	1	VACANT SITE	Plant
7	8966	KAUFFMAN AV	Front	1	VACANT SITE	Plant
7	8971	KAUFFMAN AV	Front	1	VACANT SITE	Plant
7	8991	KAUFFMAN AV	Front	1	VACANT SITE	Plant
7	9210	KAUFFMAN AV	Side	2	4600 X SOUTHERN AV	Plant
10	9233	KAUFFMAN AV	Front	1	VACANT SITE	Plant
10	9304	KAUFFMAN AV	Front	1	VACANT SITE	Plant
10	9315	KAUFFMAN AV	Front	1	VACANT SITE	Plant
10	9321	KAUFFMAN AV	Front	1	VACANT SITE	Plant
10	9414	KAUFFMAN AV	Front	1	VACANT SITE	Plant
10	9414	KAUFFMAN AV	Side	1	4601 X DUANE WY	Plant
10	9414	KAUFFMAN AV	Side	2	4601 X DUANE WY	Plant
10	9415	KAUFFMAN AV	Side	1	4585 X DUANE WY	Plant
10	9415	KAUFFMAN AV	Side	2	4585 X DUANE WY	Plant
10	9509	KAUFFMAN AV	Side	1	4570 X DUANE WY	Plant
10	9509	KAUFFMAN AV	Side	2	4570 X DUANE WY	Plant
10	9510	KAUFFMAN AV	Side	1	4600 X DUANE WY	Plant
10	9510	KAUFFMAN AV	Side	2	4600 X DUANE WY	Plant
10	9511	KAUFFMAN AV	Front	1	VACANT SITE	Plant
10	9624	KAUFFMAN AV	Front	1	VACANT SITE	Plant
10	9625	KAUFFMAN AV	Front	1	VACANT SITE	Plant

City of South Gate

Vacant Planting Sites - November 2007

DIST	HOUSE ADDRESS	SIDE	TREE	ON ADDRESS	COMMON NAME	MAINTENANCE
10	9629 KAUFFMAN AV	Front	1		VACANT SITE	Plant
10	9630 KAUFFMAN AV	Front	1		VACANT SITE	Plant
10	9639 KAUFFMAN AV	Side	1	4585 X MISSOURI AV	VACANT SITE	Plant
10	9639 KAUFFMAN AV	Side	2	4585 X MISSOURI AV	VACANT SITE	Plant
10	9707 KAUFFMAN AV	Side	1	4580 X MISSOURI AV	VACANT SITE	Plant
10	9817 KAUFFMAN AV	Front	1		VACANT SITE	Plant
14	10104 KAUFFMAN AV	Front	1		VACANT SITE	Plant
14	10105 KAUFFMAN AV	Front	1		VACANT SITE	Plant
14	10115 KAUFFMAN AV	Front	1		VACANT SITE	Plant
14	10134 KAUFFMAN AV	Side	2	4601 X MICHIGAN AV	VACANT SITE	Plant
14	10206 KAUFFMAN AV	Side	1	4600 X MICHIGAN AV	VACANT SITE	Plant
14	10206 KAUFFMAN AV	Side	2	4600 X MICHIGAN AV	VACANT SITE	Plant
14	10218 KAUFFMAN AV	Front	1		VACANT SITE	Plant
14	10238 KAUFFMAN AV	Front	1		VACANT SITE	Plant
14	10239 KAUFFMAN AV	Front	1		VACANT SITE	Plant
14	10242 KAUFFMAN AV	Front	1		VACANT SITE	Plant
14	10247 KAUFFMAN AV	Front	1		VACANT SITE	Plant
14	10311 KAUFFMAN AV	Front	1		VACANT SITE	Plant
14	10321 KAUFFMAN AV	Front	1		VACANT SITE	Plant
14	10341 KAUFFMAN AV	Front	1		VACANT SITE	Plant
14	10346 KAUFFMAN AV	Side	1	4601 X TENAYA AV	VACANT SITE	Plant
14	10346 KAUFFMAN AV	Side	2	4601 X TENAYA AV	VACANT SITE	Plant
14	10347 KAUFFMAN AV	Side	1	4535 X TENAYA AV	VACANT SITE	Plant
14	10347 KAUFFMAN AV	Side	2	4535 X TENAYA AV	VACANT SITE	Plant
14	10406 KAUFFMAN AV	Side	1	4600 X TENAYA AV	VACANT SITE	Plant
14	10407 KAUFFMAN AV	Front	1		VACANT SITE	Plant
14	10407 KAUFFMAN AV	Side	1	4560 X TENAYA AV	VACANT SITE	Plant
14	10414 KAUFFMAN AV	Front	1		VACANT SITE	Plant
14	10415 KAUFFMAN AV	Front	1		VACANT SITE	Plant
14	10517 KAUFFMAN AV	Front	1		VACANT SITE	Plant
5	2739 LAUREL PL	Front	1		VACANT SITE	Plant
5	2757 LAUREL PL	Front	1		VACANT SITE	Plant

City of South Gate
Vacant Planting Sites - November 2007

DIST	HOUSE ADDRESS	SIDE	TREE	ON ADDRESS	COMMON NAME	MAINTENANCE
5	2761 LAUREL PL	Front	1		VACANT SITE	Plant
5	2763 LAUREL PL	Front	1		VACANT SITE	Plant
5	2770 LAUREL PL	Front	1		VACANT SITE	Plant
5	2780 LAUREL PL	Front	1		VACANT SITE	Plant
5	2783 LAUREL PL	Front	1		VACANT SITE	Plant
5	2798 LAUREL PL	Front	1		VACANT SITE	Plant
3	2902 LAUREL PL	Front	1		VACANT SITE	Plant
3	2902 LAUREL PL	Front	2		VACANT SITE	Plant
3	2907 LAUREL PL	Side	1	8670 X MOUNTAIN VIEW AV	VACANT SITE	Plant
14	5202 LEDGEWOOD RD	Side	1	10400 X WRIGHT RD	VACANT SITE	Plant
14	5206 LEDGEWOOD RD	Front	1		VACANT SITE	Plant
14	5206 LEDGEWOOD RD	Front	2		VACANT SITE	Plant
14	5233 LEDGEWOOD RD	Front	1		VACANT SITE	Plant
14	5234 LEDGEWOOD RD	Front	1		VACANT SITE	Plant
14	5303 LEDGEWOOD RD	Side	2	10350 X ADELLA AV	VACANT SITE	Plant
14	5307 LEDGEWOOD RD	Front	1		VACANT SITE	Plant
14	5342 LEDGEWOOD RD	Front	1		VACANT SITE	Plant
14	5342 LEDGEWOOD RD	Side	6	10401 X BLUMONT RD	VACANT SITE	Plant
16	5800 X LEEDS ST	Front	1		VACANT SITE	Plant
16	5800 X LEEDS ST	Front	2		VACANT SITE	Plant
16	5800 X LEEDS ST	Front	3		VACANT SITE	Plant
16	5800 X LEEDS ST	Front	5		VACANT SITE	Plant
16	5901 LEEDS ST	Side	1	10810 X BEAK AV	VACANT SITE	Plant
16	5915 LEEDS ST	Front	1		VACANT SITE	Plant
1	2623 LIBERTY BL	Front	1		VACANT SITE	Plant
1	2727 LIBERTY BL	Front	1		VACANT SITE	Plant
1	2727 LIBERTY BL	Side	1	8195 X COMMERCIAL PL	VACANT SITE	Plant
1	2775 X LIBERTY BL	Front	2		VACANT SITE	Plant
1	2802 LIBERTY BL	Side	2	8400 X BEECHWOOD AV	VACANT SITE	Plant
1	2803 LIBERTY BL	Side	1	8198 X BEECHWOOD AV	VACANT SITE	Plant
1	2809 LIBERTY BL	Front	1		VACANT SITE	Plant
1	2813 LIBERTY BL	Front	1		VACANT SITE	Plant

City of South Gate

Vacant Planting Sites - November 2007

DIST	HOUSE ADDRESS	SIDE	TREE	ON ADDRESS	COMMON NAME	MAINTENANCE
1	2816 LIBERTY BL	Front	1		VACANT SITE	Plant
1	2825 X LIBERTY BL	Front	1		VACANT SITE	Plant
1	2826 LIBERTY BL	Front	1		VACANT SITE	Plant
1	2826 LIBERTY BL	Side	1	8401 X MOUNTAIN VIEW AV	VACANT SITE	Plant
1	2902 LIBERTY BL	Front	1		VACANT SITE	Plant
1	2922 LIBERTY BL	Front	1		VACANT SITE	Plant
1	2926 LIBERTY BL	Side	1	8401 X CHESTNUT AV	VACANT SITE	Plant
1	2926 LIBERTY BL	Side	2	8401 X CHESTNUT AV	VACANT SITE	Plant
1	2950 LIBERTY BL	Side	1	8400 X CHESTNUT AV	VACANT SITE	Plant
1	2953 LIBERTY BL	Side	1	8190 X CHESTNUT AV	VACANT SITE	Plant
1	2953 LIBERTY BL	Side	3	8190 X CHESTNUT AV	VACANT SITE	Plant
1	2973 LIBERTY BL	Front	1		VACANT SITE	Plant
1	2977 LIBERTY BL	Front	1		VACANT SITE	Plant
1	2977 LIBERTY BL	Side	1	8195 X EVERGREEN AV	VACANT SITE	Plant
1	3012 LIBERTY BL	Front	1		VACANT SITE	Plant
1	3026 LIBERTY BL	Side	1	8401 X CYPRESS AV	VACANT SITE	Plant
1	3026 LIBERTY BL	Side	2	8401 X CYPRESS AV	VACANT SITE	Plant
1	3052 LIBERTY BL	Side	2	8400 X CYPRESS AV	VACANT SITE	Plant
1	3070 LIBERTY BL	Front	1		VACANT SITE	Plant
1	3076 LIBERTY BL	Front	1		VACANT SITE	Plant
1	3079 LIBERTY BL	Side	1	8195 X GARDEN VIEW AV	VACANT SITE	Plant
1	3103 LIBERTY BL	Front	1		VACANT SITE	Plant
1	3103 LIBERTY BL	Side	1	8190 X GARDEN VIEW AV	VACANT SITE	Plant
1	3103 LIBERTY BL	Side	2	8190 X GARDEN VIEW AV	VACANT SITE	Plant
1	3106 LIBERTY BL	Front	1		VACANT SITE	Plant
1	3114 LIBERTY BL	Front	1		VACANT SITE	Plant
1	3118 LIBERTY BL	Front	1		VACANT SITE	Plant
1	3119 LIBERTY BL	Front	1		VACANT SITE	Plant
1	3176 LIBERTY BL	Front	1		VACANT SITE	Plant
1	3176 LIBERTY BL	Side	1	8401 X MADISON AV	VACANT SITE	Plant
1	3176 LIBERTY BL	Side	2	8401 X MADISON AV	VACANT SITE	Plant
1	3176 LIBERTY BL	Side	3	8401 X MADISON AV	VACANT SITE	Plant

City of South Gate
Vacant Planting Sites - November 2007

DIST	HOUSE ADDRESS	SIDE	TREE	ON ADDRESS	COMMON NAME	MAINTENANCE
1	3177 LIBERTY BL	Front	1		VACANT SITE	Plant
1	3177 LIBERTY BL	Side	1	8195 X MADISON AV	VACANT SITE	Plant
1	3177 LIBERTY BL	Side	2	8195 X MADISON AV	VACANT SITE	Plant
1	3206 LIBERTY BL	Front	1		VACANT SITE	Plant
1	3260 LIBERTY BL	Front	3		VACANT SITE	Plant
1	3268 LIBERTY BL	Front	1		VACANT SITE	Plant
1	3272 LIBERTY BL	Front	1		VACANT SITE	Plant
1	3277 LIBERTY BL	Side	1	8195 X DEARBORN AV	VACANT SITE	Plant
1	3300 LIBERTY BL	Front	1		VACANT SITE	Plant
1	3300 LIBERTY BL	Front	2		VACANT SITE	Plant
1	3300 LIBERTY BL	Front	4		VACANT SITE	Plant
1	3300 LIBERTY BL	Side	1	8400 X DEARBORN AV	VACANT SITE	Plant
1	3300 LIBERTY BL	Side	2	8400 X DEARBORN AV	VACANT SITE	Plant
1	3301 LIBERTY BL	Front	1		VACANT SITE	Plant
1	3301 LIBERTY BL	Side	1	8190 X DEARBORN AV	VACANT SITE	Plant
1	3320 LIBERTY BL	Front	1		VACANT SITE	Plant
1	3326 LIBERTY BL	Front	1		VACANT SITE	Plant
1	3350 LIBERTY BL	Side	1	8400 X VICTORIA AV	VACANT SITE	Plant
1	3354 LIBERTY BL	Front	1		VACANT SITE	Plant
1	3361 LIBERTY BL	Front	1		VACANT SITE	Plant
1	3364 LIBERTY BL	Front	1		VACANT SITE	Plant
1	3365 LIBERTY BL	Front	1		VACANT SITE	Plant
1	3376 LIBERTY BL	Front	1		VACANT SITE	Plant
1	3380 LIBERTY BL	Side	1	8401 X ELIZABETH AV	VACANT SITE	Plant
1	3381 LIBERTY BL	Front	1		VACANT SITE	Plant
1	3381 LIBERTY BL	Side	1	8191 X ELIZABETH AV	VACANT SITE	Plant
1	3403 LIBERTY BL	Front	1		VACANT SITE	Plant
1	3403 LIBERTY BL	Side	1	8190 X ELIZABETH AV	VACANT SITE	Plant
1	3414 LIBERTY BL	Front	1		VACANT SITE	Plant
1	3415 LIBERTY BL	Front	1		VACANT SITE	Plant
1	3419 LIBERTY BL	Front	1		VACANT SITE	Plant
1	3452 LIBERTY BL	Front	1		VACANT SITE	Plant

City of South Gate

Vacant Planting Sites - November 2007

DIST	HOUSE ADDRESS	SIDE	TREE	ON ADDRESS	COMMON NAME	MAINTENANCE
1	3452 LIBERTY BL	Side	1	8400 X VIRGINIA AV	VACANT SITE	Plant
1	3453 LIBERTY BL	Side	1	8190 X VIRGINIA AV	VACANT SITE	Plant
1	3453 LIBERTY BL	Side	2	8190 X VIRGINIA AV	VACANT SITE	Plant
1	3453 LIBERTY BL	Side	3	8190 X VIRGINIA AV	VACANT SITE	Plant
1	3457 LIBERTY BL	Front	1		VACANT SITE	Plant
1	3461 LIBERTY BL	Front	1		VACANT SITE	Plant
1	3469 LIBERTY BL	Front	1		VACANT SITE	Plant
2	3520 LIBERTY BL	Front	1		VACANT SITE	Plant
2	3523 LIBERTY BL	Front	1		VACANT SITE	Plant
2	3527 LIBERTY BL	Side	1	8195 X SAN ANTONIO AV	VACANT SITE	Plant
2	3603 LIBERTY BL	Side	1	8190 X SAN ANTONIO AV	VACANT SITE	Plant
2	3603 LIBERTY BL	Side	2	8190 X SAN ANTONIO AV	VACANT SITE	Plant
2	3612 LIBERTY BL	Front	1		VACANT SITE	Plant
2	3616 LIBERTY BL	Front	1		VACANT SITE	Plant
2	3617 LIBERTY BL	Front	1		VACANT SITE	Plant
2	3620 LIBERTY BL	Front	1		VACANT SITE	Plant
2	3621 LIBERTY BL	Front	1		VACANT SITE	Plant
2	3625 LIBERTY BL	Front	1		VACANT SITE	Plant
2	3625 LIBERTY BL	Front	2		VACANT SITE	Plant
2	3625 LIBERTY BL	Side	1	8195 X SAN CARLOS AV	VACANT SITE	Plant
2	3626 LIBERTY BL	Side	1	8401 X SAN CARLOS AV	VACANT SITE	Plant
2	3709 LIBERTY BL	Front	1		VACANT SITE	Plant
2	3716 LIBERTY BL	Front	1		VACANT SITE	Plant
2	3720 LIBERTY BL	Front	1		VACANT SITE	Plant
2	3721 LIBERTY BL	Front	1		VACANT SITE	Plant
2	3721 LIBERTY BL	Side	1	8195 X SAN GABRIEL AV	VACANT SITE	Plant
2	3721 LIBERTY BL	Side	2	8195 X SAN GABRIEL AV	VACANT SITE	Plant
2	3724 LIBERTY BL	Front	1		VACANT SITE	Plant
2	3803 LIBERTY BL	Front	1		VACANT SITE	Plant
2	3803 LIBERTY BL	Side	1	8190 X SAN GABRIEL AV	VACANT SITE	Plant
2	3803 LIBERTY BL	Side	2	8190 X SAN GABRIEL AV	VACANT SITE	Plant
2	3807 LIBERTY BL	Front	1		VACANT SITE	Plant

City of South Gate
Vacant Planting Sites - November 2007

DIST	HOUSE ADDRESS	SIDE	TREE	ON ADDRESS	COMMON NAME	MAINTENANCE
2	3824 LIBERTY BL	Front	1		VACANT SITE	Plant
2	3824 LIBERTY BL	Side	1	8401 X SAN JUAN AV	VACANT SITE	Plant
2	3906 LIBERTY BL	Front	1		VACANT SITE	Plant
2	3907 LIBERTY BL	Front	1		VACANT SITE	Plant
2	3916 LIBERTY BL	Front	1		VACANT SITE	Plant
2	4006 LIBERTY BL	Side	2	8400 X SAN LUIS AV	VACANT SITE	Plant
2	4008 LIBERTY BL	Front	1		VACANT SITE	Plant
2	4011 LIBERTY BL	Front	1		VACANT SITE	Plant
2	4016 LIBERTY BL	Front	1		VACANT SITE	Plant
2	4024 LIBERTY BL	Side	1	8401 X SAN MIGUEL AV	VACANT SITE	Plant
2	4024 LIBERTY BL	Side	3	8401 X SAN MIGUEL AV	VACANT SITE	Plant
2	4027 LIBERTY BL	Side	1	8195 X SAN MIGUEL AV	VACANT SITE	Plant
2	4054 LIBERTY BL	Front	2		VACANT SITE	Plant
2	4062 LIBERTY BL	Front	1		VACANT SITE	Plant
2	4071 LIBERTY BL	Front	1		VACANT SITE	Plant
2	4076 LIBERTY BL	Front	1		VACANT SITE	Plant
2	4109 LIBERTY BL	Front	1		VACANT SITE	Plant
2	4111 LIBERTY BL	Front	1		VACANT SITE	Plant
2	4116 LIBERTY BL	Front	1		VACANT SITE	Plant
2	4117 LIBERTY BL	Front	1		VACANT SITE	Plant
2	4125 LIBERTY BL	Front	1		VACANT SITE	Plant
2	4131 LIBERTY BL	Front	1		VACANT SITE	Plant
16	10929 LILLIAN LN	Front	1		VACANT SITE	Plant
16	10950 LILLIAN LN	Front	1		VACANT SITE	Plant
16	10955 LILLIAN LN	Front	1		VACANT SITE	Plant
16	10960 LILLIAN LN	Front	1		VACANT SITE	Plant
16	10965 LILLIAN LN	Front	1		VACANT SITE	Plant
16	10970 LILLIAN LN	Front	1		VACANT SITE	Plant
16	10980 LILLIAN LN	Front	1		VACANT SITE	Plant
16	10985 LILLIAN LN	Front	1		VACANT SITE	Plant
16	10990 LILLIAN LN	Front	1		VACANT SITE	Plant
16	10995 LILLIAN LN	Front	1		VACANT SITE	Plant

City of South Gate

Vacant Planting Sites - November 2007

DIST	HOUSE ADDRESS	SIDE	TREE	ON ADDRESS	COMMON NAME	MAINTENANCE	
16	11000	LILLIAN LN	Front	1		VACANT SITE	Plant
16	11010	LILLIAN LN	Front	1		VACANT SITE	Plant
16	11015	LILLIAN LN	Front	1		VACANT SITE	Plant
16	11020	LILLIAN LN	Front	1		VACANT SITE	Plant
16	11030	LILLIAN LN	Front	1		VACANT SITE	Plant
16	11035	LILLIAN LN	Front	1		VACANT SITE	Plant
16	11040	LILLIAN LN	Front	1		VACANT SITE	Plant
16	11045	LILLIAN LN	Front	1		VACANT SITE	Plant
16	11050	LILLIAN LN	Front	1		VACANT SITE	Plant
16	11050	LILLIAN LN	Front	2		VACANT SITE	Plant
17	5722	LINCOLN AV	Front	1		VACANT SITE	Plant
17	5742	LINCOLN AV	Front	1		VACANT SITE	Plant
17	5757	LINCOLN AV	Front	1		VACANT SITE	Plant
17	5766	LINCOLN AV	Front	1		VACANT SITE	Plant
18	6008	LINCOLN AV	Front	3		VACANT SITE	Plant
18	6021	LINCOLN AV	Front	1		VACANT SITE	Plant
18	6040	LINCOLN AV	Front	1		VACANT SITE	Plant
18	6045	LINCOLN AV	Front	1		VACANT SITE	Plant
18	6056	LINCOLN AV	Side	2	12300 X HOOVER AV	VACANT SITE	Plant
18	6057	LINCOLN AV	Side	1	12225 X HOOVER AV	VACANT SITE	Plant
18	6100	LINCOLN AV	Front	1		VACANT SITE	Plant
18	6100	LINCOLN AV	Side	1	12301 X HOOVER AV	VACANT SITE	Plant
18	6136	LINCOLN AV	Front	1		VACANT SITE	Plant
18	6166	LINCOLN AV	Front	1		VACANT SITE	Plant
1	8200	LONG BEACH BL	Front	2		VACANT SITE	Plant
1	8200	LONG BEACH BL	Front	4		VACANT SITE	Plant
1	8200	LONG BEACH BL	Front	7		VACANT SITE	Plant
1	8204	LONG BEACH BL	Side	1	2601 X PINE PL	VACANT SITE	Plant
1	8253	LONG BEACH BL	Front	1		VACANT SITE	Plant
1	8275	LONG BEACH BL	Front	1		VACANT SITE	Plant
1	8329	LONG BEACH BL	Front	1		VACANT SITE	Plant
1	8427	LONG BEACH BL	Front	1		VACANT SITE	Plant

City of South Gate
Vacant Planting Sites - November 2007

DIST	HOUSE ADDRESS	SIDE	TREE	ON ADDRESS	COMMON NAME	MAINTENANCE
5	8627 LONG BEACH BL	Front	1		VACANT SITE	Plant
5	8635 LONG BEACH BL	Side	1	2785 X ORCHARD PL	VACANT SITE	Plant
5	8635 LONG BEACH BL	Side	2	2785 X ORCHARD PL	VACANT SITE	Plant
3	8700 LONG BEACH BL	Side	1	2800 X ORCHARD PL	VACANT SITE	Plant
3	8700 LONG BEACH BL	Side	3	2800 X ORCHARD PL	VACANT SITE	Plant
3	8700 LONG BEACH BL	Side	4	2800 X ORCHARD PL	VACANT SITE	Plant
3	8700 LONG BEACH BL	Side	5	2800 X ORCHARD PL	VACANT SITE	Plant
3	8700 LONG BEACH BL	Side	6	2800 X ORCHARD PL	VACANT SITE	Plant
5	8707 LONG BEACH BL	Front	1		VACANT SITE	Plant
5	8707 LONG BEACH BL	Front	2		VACANT SITE	Plant
5	8800 LONG BEACH BL	Front	1		VACANT SITE	Plant
5	8824 LONG BEACH BL	Front	2		VACANT SITE	Plant
5	8900 X LONG BEACH BL	Front	1		VACANT SITE	Plant
5	8926 LONG BEACH BL	Front	2		VACANT SITE	Plant
5	8935 LONG BEACH BL	Side	1	2825 X WILLOW PL	VACANT SITE	Plant
5	8935 LONG BEACH BL	Side	2	2825 X WILLOW PL	VACANT SITE	Plant
5	8935 LONG BEACH BL	Side	3	2825 X WILLOW PL	VACANT SITE	Plant
5	8935 LONG BEACH BL	Side	4	2825 X WILLOW PL	VACANT SITE	Plant
5	8935 LONG BEACH BL	Side	5	2825 X WILLOW PL	VACANT SITE	Plant
6	9010 LONG BEACH BL	Side	6	2900 X WILLOW PL	VACANT SITE	Plant
5	9015 LONG BEACH BL	Front	1		VACANT SITE	Plant
5	9100 X LONG BEACH BL	Front	5		VACANT SITE	Plant
5	9100 X LONG BEACH BL	Front	6		VACANT SITE	Plant
5	9111 LONG BEACH BL	Front	2		VACANT SITE	Plant
5	9111 LONG BEACH BL	Side	1	2840 X GLENWOOD PL	VACANT SITE	Plant
5	9125 LONG BEACH BL	Front	2		VACANT SITE	Plant
5	9201 LONG BEACH BL	Side	1	2870 X SOUTHERN AV	VACANT SITE	Plant
5	9235 LONG BEACH BL	Front	1		VACANT SITE	Plant
5	9325 LONG BEACH BL	Front	1		VACANT SITE	Plant
5	9334 LONG BEACH BL	Front	1		VACANT SITE	Plant
5	9334 LONG BEACH BL	Front	3		VACANT SITE	Plant
5	9420 LONG BEACH BL	Front	1		VACANT SITE	Plant

City of South Gate

Vacant Planting Sites - November 2007

DIST	HOUSE ADDRESS	SIDE	TREE	ON ADDRESS	COMMON NAME	MAINTENANCE
8	9434 LONG BEACH BL	Side	2	3035 X OHIO AV	VACANT SITE	Plant
8	9434 LONG BEACH BL	Side	3	3035 X OHIO AV	VACANT SITE	Plant
8	9506 LONG BEACH BL	Side	2	3040 X OHIO AV	VACANT SITE	Plant
5	9720 LONG BEACH BL	Front	1		VACANT SITE	Plant
5	9720 LONG BEACH BL	Front	2		VACANT SITE	Plant
5	9735 LONG BEACH BL	Front	1		VACANT SITE	Plant
8	9812 LONG BEACH BL	Side	1	3100 X INDIANA AV	VACANT SITE	Plant
8	9812 LONG BEACH BL	Side	2	3100 X INDIANA AV	VACANT SITE	Plant
8	9812 LONG BEACH BL	Side	3	3100 X INDIANA AV	VACANT SITE	Plant
5	9828 LONG BEACH BL	Front	3		VACANT SITE	Plant
7	8945 LOTTA AV	Front	1		VACANT SITE	Plant
7	8955 X LOTTA AV	Front	1		VACANT SITE	Plant
7	8955 X LOTTA AV	Front	2		VACANT SITE	Plant
7	8965 X LOTTA AV	Front	1		VACANT SITE	Plant
7	8973 LOTTA AV	Front	1		VACANT SITE	Plant
7	8981 LOTTA AV	Side	1	4915 X BRANYON AV	VACANT SITE	Plant
7	8981 LOTTA AV	Side	2	4915 X BRANYON AV	VACANT SITE	Plant
7	8981 LOTTA AV	Side	3	4915 X BRANYON AV	VACANT SITE	Plant
15	6019 LUXOR ST	Front	1		VACANT SITE	Plant
15	6020 LUXOR ST	Front	1		VACANT SITE	Plant
15	6025 LUXOR ST	Front	1		VACANT SITE	Plant
16	10711 MADGE AV	Front	1		VACANT SITE	Plant
16	10726 MADGE AV	Front	1		VACANT SITE	Plant
16	10730 MADGE AV	Front	1		VACANT SITE	Plant
16	10737 MADGE AV	Front	1		VACANT SITE	Plant
16	10750 MADGE AV	Front	1		VACANT SITE	Plant
16	10751 MADGE AV	Front	1		VACANT SITE	Plant
16	10756 MADGE AV	Front	1		VACANT SITE	Plant
16	10757 MADGE AV	Front	1		VACANT SITE	Plant
16	10800 MADGE AV	Front	1		VACANT SITE	Plant
16	10806 MADGE AV	Front	1		VACANT SITE	Plant
16	10811 MADGE AV	Front	1		VACANT SITE	Plant

City of South Gate
Vacant Planting Sites - November 2007

DIST	HOUSE ADDRESS	SIDE	TREE	ON ADDRESS	COMMON NAME	MAINTENANCE
16	10821 MADGE AV	Front	1		VACANT SITE	Plant
1	8103 MADISON AV	Side	1	3176 X SANTA ANA ST	VACANT SITE	Plant
1	8120 MADISON AV	Front	1		VACANT SITE	Plant
1	8125 MADISON AV	Front	1		VACANT SITE	Plant
1	8129 MADISON AV	Front	1		VACANT SITE	Plant
1	8137 MADISON AV	Front	1		VACANT SITE	Plant
1	8138 MADISON AV	Front	1		VACANT SITE	Plant
1	8142 MADISON AV	Front	1		VACANT SITE	Plant
1	8147 MADISON AV	Front	1		VACANT SITE	Plant
1	8152 MADISON AV	Front	1		VACANT SITE	Plant
1	8160 MADISON AV	Front	1		VACANT SITE	Plant
1	8164 MADISON AV	Front	1		VACANT SITE	Plant
1	8167 MADISON AV	Front	1		VACANT SITE	Plant
1	8180 MADISON AV	Front	1		VACANT SITE	Plant
1	8181 MADISON AV	Front	1		VACANT SITE	Plant
1	8184 MADISON AV	Front	1		VACANT SITE	Plant
1	8402 MADISON AV	Side	1	3200 X LIBERTY BL	VACANT SITE	Plant
1	8404 MADISON AV	Front	1		VACANT SITE	Plant
1	8416 MADISON AV	Front	1		VACANT SITE	Plant
1	8431 MADISON AV	Side	1	3180 X POST ST	VACANT SITE	Plant
1	8457 MADISON AV	Front	1		VACANT SITE	Plant
1	8465 MADISON AV	Front	1		VACANT SITE	Plant
3	8617 MADISON AV	Front	1		VACANT SITE	Plant
3	8621 MADISON AV	Front	1		VACANT SITE	Plant
3	8629 MADISON AV	Front	1		VACANT SITE	Plant
3	8636 MADISON AV	Front	1		VACANT SITE	Plant
3	8640 MADISON AV	Front	1		VACANT SITE	Plant
3	8644 MADISON AV	Front	1		VACANT SITE	Plant
3	8645 MADISON AV	Front	1		VACANT SITE	Plant
3	8660 X MADISON AV	Front	3		VACANT SITE	Plant
3	8665 MADISON AV	Front	1		VACANT SITE	Plant
3	8673 MADISON AV	Front	1		VACANT SITE	Plant

City of South Gate

Vacant Planting Sites - November 2007

DIST	HOUSE ADDRESS	SIDE	TREE	ON ADDRESS	COMMON NAME	MAINTENANCE
6	8901 X MADISON AV	Front	1		VACANT SITE	Plant
6	8901 X MADISON AV	Front	2		VACANT SITE	Plant
6	8923 MADISON AV	Front	1		VACANT SITE	Plant
6	8931 MADISON AV	Front	1		VACANT SITE	Plant
6	8961 MADISON AV	Front	1		VACANT SITE	Plant
6	8973 MADISON AV	Front	1		VACANT SITE	Plant
8	9419 MADISON AV	Front	1		VACANT SITE	Plant
8	9523 MADISON AV	Front	1		VACANT SITE	Plant
8	9527 MADISON AV	Side	1	3185 X KANSAS AV	VACANT SITE	Plant
8	9600 MADISON AV	Front	1		VACANT SITE	Plant
8	9602 MADISON AV	Front	1		VACANT SITE	Plant
8	9610 X MADISON AV	Front	1		VACANT SITE	Plant
8	9706 MADISON AV	Front	1		VACANT SITE	Plant
8	9718 MADISON AV	Front	1		VACANT SITE	Plant
8	9730 MADISON AV	Front	1		VACANT SITE	Plant
8	9733 MADISON AV	Side	1	3165 X INDIANA AV	VACANT SITE	Plant
8	9807 MADISON AV	Front	1		VACANT SITE	Plant
17	5737 MAIN ST	Front	1		VACANT SITE	Plant
17	5747 MAIN ST	Front	1		VACANT SITE	Plant
17	5750 MAIN ST	Front	1		VACANT SITE	Plant
17	5751 MAIN ST	Front	1		VACANT SITE	Plant
17	5757 MAIN ST	Front	1		VACANT SITE	Plant
17	5760 MAIN ST	Front	1		VACANT SITE	Plant
17	5767 MAIN ST	Front	1		VACANT SITE	Plant
17	5792 MAIN ST	Side	3	12101 X CENTER ST	VACANT SITE	Plant
18	6017 MAIN ST	Front	1		VACANT SITE	Plant
18	6031 MAIN ST	Front	1		VACANT SITE	Plant
18	6056 MAIN ST	Front	1		VACANT SITE	Plant
18	6060 MAIN ST	Front	1		VACANT SITE	Plant
18	6061 MAIN ST	Front	1		VACANT SITE	Plant
18	6070 MAIN ST	Front	1		VACANT SITE	Plant
18	6106 MAIN ST	Front	1		VACANT SITE	Plant

City of South Gate
Vacant Planting Sites - November 2007

DIST	HOUSE ADDRESS	SIDE	TREE	ON ADDRESS	COMMON NAME	MAINTENANCE
18	6126 MAIN ST	Front	1		VACANT SITE	Plant
18	6147 MAIN ST	Front	1		VACANT SITE	Plant
18	6156 MAIN ST	Front	1		VACANT SITE	Plant
18	6159 MAIN ST	Front	1		VACANT SITE	Plant
9	9213 MALLISON AV	Front	1		VACANT SITE	Plant
9	9316 MALLISON AV	Front	1		VACANT SITE	Plant
9	9326 MALLISON AV	Front	1		VACANT SITE	Plant
9	9332 MALLISON AV	Front	1		VACANT SITE	Plant
9	9334 MALLISON AV	Front	1		VACANT SITE	Plant
9	9418 MALLISON AV	Front	1		VACANT SITE	Plant
9	9418 MALLISON AV	Side	1	4155 X DUANE WY	VACANT SITE	Plant
9	9504 MALLISON AV	Side	1	4140 X DUANE WY	VACANT SITE	Plant
9	9536 MALLISON AV	Front	1		VACANT SITE	Plant
9	9634 MALLISON AV	Front	1		VACANT SITE	Plant
9	9637 MALLISON AV	Front	1		VACANT SITE	Plant
9	9711 MALLISON AV	Front	1		VACANT SITE	Plant
13	10018 MALLISON AV	Front	1		VACANT SITE	Plant
13	10024 MALLISON AV	Front	1		VACANT SITE	Plant
13	10119 MALLISON AV	Front	1		VACANT SITE	Plant
13	10141 MALLISON AV	Side	1	4099 X MICHIGAN AV	VACANT SITE	Plant
13	10207 MALLISON AV	Side	1	4098 X MICHIGAN AV	VACANT SITE	Plant
13	10210 MALLISON AV	Side	1	4100 X MICHIGAN AV	VACANT SITE	Plant
13	10217 MALLISON AV	Front	1		VACANT SITE	Plant
13	10228 MALLISON AV	Front	1		VACANT SITE	Plant
13	10229 MALLISON AV	Front	1		VACANT SITE	Plant
13	10301 MALLISON AV	Front	1		VACANT SITE	Plant
13	10318 MALLISON AV	Front	1		VACANT SITE	Plant
13	10330 MALLISON AV	Front	1		VACANT SITE	Plant
13	10331 MALLISON AV	Front	1		VACANT SITE	Plant
13	10336 MALLISON AV	Front	1		VACANT SITE	Plant
13	10340 MALLISON AV	Front	1		VACANT SITE	Plant
13	10345 MALLISON AV	Front	1		VACANT SITE	Plant

City of South Gate

Vacant Planting Sites - November 2007

DIST	HOUSE ADDRESS	SIDE	TREE	ON ADDRESS	COMMON NAME	MAINTENANCE	
13	10346	MALLISON AV	Front	1		VACANT SITE	Plant
13	10353	MALLISON AV	Side	1	4145 X TENAYA AV	VACANT SITE	Plant
13	10405	MALLISON AV	Front	1		VACANT SITE	Plant
13	10405	MALLISON AV	Side	1	4150 X TENAYA AV	VACANT SITE	Plant
13	10405	MALLISON AV	Side	2	4150 X TENAYA AV	VACANT SITE	Plant
13	10408	MALLISON AV	Front	1		VACANT SITE	Plant
13	10414	MALLISON AV	Front	1		VACANT SITE	Plant
13	10419	MALLISON AV	Front	1		VACANT SITE	Plant
13	10420	MALLISON AV	Front	1		VACANT SITE	Plant
13	10427	MALLISON AV	Front	1		VACANT SITE	Plant
13	10433	MALLISON AV	Front	1		VACANT SITE	Plant
13	10438	MALLISON AV	Front	1		VACANT SITE	Plant
13	10439	MALLISON AV	Front	1		VACANT SITE	Plant
13	10502	MALLISON AV	Front	1		VACANT SITE	Plant
13	10508	MALLISON AV	Front	1		VACANT SITE	Plant
13	10514	MALLISON AV	Front	1		VACANT SITE	Plant
13	10515	MALLISON AV	Front	1		VACANT SITE	Plant
13	10521	MALLISON AV	Front	1		VACANT SITE	Plant
13	10526	MALLISON AV	Front	1		VACANT SITE	Plant
13	10527	MALLISON AV	Front	1		VACANT SITE	Plant
13	10530	MALLISON AV	Front	1		VACANT SITE	Plant
13	10601	MALLISON AV	Front	1		VACANT SITE	Plant
13	10606	MALLISON AV	Front	1		VACANT SITE	Plant
13	10612	MALLISON AV	Front	1		VACANT SITE	Plant
7	8967	MAY CT	Front	1		VACANT SITE	Plant
10	5125	MCCALLUM AV	Front	1		VACANT SITE	Plant
10	5125	MCCALLUM AV	Front	2		VACANT SITE	Plant
10	5126	MCCALLUM AV	Front	1		VACANT SITE	Plant
10	5130	MCCALLUM AV	Front	1		VACANT SITE	Plant
10	5131	MCCALLUM AV	Front	1		VACANT SITE	Plant
10	5135	MCCALLUM AV	Front	1		VACANT SITE	Plant
10	5142	MCCALLUM AV	Front	1		VACANT SITE	Plant

City of South Gate
Vacant Planting Sites - November 2007

DIST	HOUSE ADDRESS	SIDE	TREE	ON ADDRESS	COMMON NAME	MAINTENANCE
10	5143	MCCALLUM AV	Front	1	VACANT SITE	Plant
10	5146	MCCALLUM AV	Front	1	VACANT SITE	Plant
10	5147	MCCALLUM AV	Front	1	VACANT SITE	Plant
10	5150	MCCALLUM AV	Front	1	VACANT SITE	Plant
10	5151	MCCALLUM AV	Front	1	VACANT SITE	Plant
10	5155	MCCALLUM AV	Front	1	VACANT SITE	Plant
10	5158	MCCALLUM AV	Front	1	VACANT SITE	Plant
10	5159	MCCALLUM AV	Front	1	VACANT SITE	Plant
10	5162	MCCALLUM AV	Front	1	VACANT SITE	Plant
10	5171	MCCALLUM AV	Front	1	VACANT SITE	Plant
10	5171	MCCALLUM AV	Side	1 9525 X ADELLA AV	VACANT SITE	Plant
10	5210	MCCALLUM AV	Side	1 9600 X ADELLA AV	VACANT SITE	Plant
10	5215	MCCALLUM AV	Front	1	VACANT SITE	Plant
10	5218	MCCALLUM AV	Front	1	VACANT SITE	Plant
10	5223	MCCALLUM AV	Front	1	VACANT SITE	Plant
10	5227	MCCALLUM AV	Front	1	VACANT SITE	Plant
10	5230	MCCALLUM AV	Front	1	VACANT SITE	Plant
10	5234	MCCALLUM AV	Front	1	VACANT SITE	Plant
10	5246	MCCALLUM AV	Front	1	VACANT SITE	Plant
10	5246	MCCALLUM AV	Front	2	VACANT SITE	Plant
17	5650	MCKINLEY AV	Front	2	VACANT SITE	Plant
17	5731	MCKINLEY AV	Front	1	VACANT SITE	Plant
17	5751	MCKINLEY AV	Front	1	VACANT SITE	Plant
17	5754	MCKINLEY AV	Front	1	VACANT SITE	Plant
17	5767	MCKINLEY AV	Front	1	VACANT SITE	Plant
18	5937	MCKINLEY AV	Front	1	VACANT SITE	Plant
18	5971	MCKINLEY AV	Side	2 11725 X ARIZONA AV	VACANT SITE	Plant
18	6001	MCKINLEY AV	Side	1 11720 X ARIZONA AV	VACANT SITE	Plant
18	6001	MCKINLEY AV	Side	2 11720 X ARIZONA AV	VACANT SITE	Plant
18	6016	MCKINLEY AV	Front	1	VACANT SITE	Plant
18	6017	MCKINLEY AV	Front	1	VACANT SITE	Plant
18	6063	MCKINLEY AV	Front	1	VACANT SITE	Plant

City of South Gate

Vacant Planting Sites - November 2007

DIST	HOUSE ADDRESS	SIDE	TREE	ON ADDRESS	COMMON NAME	MAINTENANCE
18	6072	MCKINLEY AV	Front	1	VACANT SITE	Plant
18	6100	MCKINLEY AV	Front	1	VACANT SITE	Plant
18	6101	MCKINLEY AV	Side	1 11820 X HOOVER AV	VACANT SITE	Plant
18	6123	MCKINLEY AV	Front	1	VACANT SITE	Plant
18	6126	MCKINLEY AV	Front	1	VACANT SITE	Plant
18	6136	MCKINLEY AV	Front	1	VACANT SITE	Plant
18	6137	MCKINLEY AV	Front	1	VACANT SITE	Plant
18	6142	MCKINLEY AV	Front	1	VACANT SITE	Plant
18	6146	MCKINLEY AV	Front	1	VACANT SITE	Plant
18	6156	MCKINLEY AV	Front	1	VACANT SITE	Plant
18	6165	MCKINLEY AV	Front	1	VACANT SITE	Plant
7	8914	MCNERNEY AV	Front	1	VACANT SITE	Plant
7	8915	MCNERNEY AV	Front	1	VACANT SITE	Plant
7	8919	MCNERNEY AV	Front	1	VACANT SITE	Plant
7	8928	MCNERNEY AV	Front	1	VACANT SITE	Plant
7	8934	MCNERNEY AV	Front	1	VACANT SITE	Plant
7	8937	MCNERNEY AV	Front	1	VACANT SITE	Plant
7	8938	MCNERNEY AV	Front	1	VACANT SITE	Plant
7	8941 X	MCNERNEY AV	Front	1	VACANT SITE	Plant
7	8944	MCNERNEY AV	Front	1	VACANT SITE	Plant
7	8947	MCNERNEY AV	Front	1	VACANT SITE	Plant
7	8948	MCNERNEY AV	Front	1	VACANT SITE	Plant
7	8949	MCNERNEY AV	Front	1	VACANT SITE	Plant
7	8963	MCNERNEY AV	Front	1	VACANT SITE	Plant
7	8964	MCNERNEY AV	Front	2	VACANT SITE	Plant
7	8970	MCNERNEY AV	Front	1	VACANT SITE	Plant
7	8970	MCNERNEY AV	Front	2	VACANT SITE	Plant
7	8986	MCNERNEY AV	Front	1	VACANT SITE	Plant
7	8990	MCNERNEY AV	Front	1	VACANT SITE	Plant
7	8994	MCNERNEY AV	Front	1	VACANT SITE	Plant
7	8997	MCNERNEY AV	Front	1	VACANT SITE	Plant
7	9000	MCNERNEY AV	Front	1	VACANT SITE	Plant

City of South Gate
Vacant Planting Sites - November 2007

DIST	HOUSE ADDRESS	SIDE	TREE	ON ADDRESS	COMMON NAME	MAINTENANCE
7	9202 MCNERNEY AV	Side	1	4300 X SOUTHERN AV	VACANT SITE	Plant
7	9202 MCNERNEY AV	Side	2	4300 X SOUTHERN AV	VACANT SITE	Plant
9	9222 MCNERNEY AV	Front	1		VACANT SITE	Plant
9	9226 MCNERNEY AV	Front	1		VACANT SITE	Plant
9	9234 MCNERNEY AV	Front	1		VACANT SITE	Plant
9	9304 MCNERNEY AV	Front	1		VACANT SITE	Plant
9	9305 MCNERNEY AV	Front	1		VACANT SITE	Plant
9	9312 MCNERNEY AV	Front	1		VACANT SITE	Plant
9	9321 MCNERNEY AV	Front	2		VACANT SITE	Plant
9	9335 MCNERNEY AV	Front	1		VACANT SITE	Plant
9	9402 MCNERNEY AV	Front	1		VACANT SITE	Plant
9	9404 MCNERNEY AV	Front	1		VACANT SITE	Plant
9	9410 MCNERNEY AV	Front	1		VACANT SITE	Plant
9	9418 MCNERNEY AV	Side	1	4301 X DUANE WY	VACANT SITE	Plant
9	9505 MCNERNEY AV	Side	1	4230 X DUANE WY	VACANT SITE	Plant
9	9512 MCNERNEY AV	Front	1		VACANT SITE	Plant
9	9513 MCNERNEY AV	Front	1		VACANT SITE	Plant
9	9514 MCNERNEY AV	Front	1		VACANT SITE	Plant
9	9517 MCNERNEY AV	Front	1		VACANT SITE	Plant
9	9523 MCNERNEY AV	Front	1		VACANT SITE	Plant
9	9528 MCNERNEY AV	Front	1		VACANT SITE	Plant
9	9532 MCNERNEY AV	Front	1		VACANT SITE	Plant
9	9536 MCNERNEY AV	Front	1		VACANT SITE	Plant
9	9540 MCNERNEY AV	Front	1		VACANT SITE	Plant
9	9544 MCNERNEY AV	Front	1		VACANT SITE	Plant
9	9548 MCNERNEY AV	Front	1		VACANT SITE	Plant
9	9609 MCNERNEY AV	Front	1		VACANT SITE	Plant
9	9613 MCNERNEY AV	Front	1		VACANT SITE	Plant
9	9614 MCNERNEY AV	Front	1		VACANT SITE	Plant
9	9616 MCNERNEY AV	Front	1		VACANT SITE	Plant
9	9617 MCNERNEY AV	Front	1		VACANT SITE	Plant
9	9625 MCNERNEY AV	Front	1		VACANT SITE	Plant

City of South Gate

Vacant Planting Sites - November 2007

DIST	HOUSE ADDRESS	SIDE	TREE	ON ADDRESS	COMMON NAME	MAINTENANCE	
9	9632	MCNERNEY AV	Front	1		VACANT SITE	Plant
9	9715	MCNERNEY AV	Front	1		VACANT SITE	Plant
9	9719	MCNERNEY AV	Front	1		VACANT SITE	Plant
9	9722	MCNERNEY AV	Front	1		VACANT SITE	Plant
9	9727	MCNERNEY AV	Front	1		VACANT SITE	Plant
9	9731	MCNERNEY AV	Front	1		VACANT SITE	Plant
9	9736	MCNERNEY AV	Front	1		VACANT SITE	Plant
9	9801	MCNERNEY AV	Front	1		VACANT SITE	Plant
9	9808	MCNERNEY AV	Front	1		VACANT SITE	Plant
9	9811	MCNERNEY AV	Front	1		VACANT SITE	Plant
9	9812	MCNERNEY AV	Front	1		VACANT SITE	Plant
9	9813	MCNERNEY AV	Front	1		VACANT SITE	Plant
9	9825	MCNERNEY AV	Front	1		VACANT SITE	Plant
13	10011	MCNERNEY AV	Front	1		VACANT SITE	Plant
13	10019	MCNERNEY AV	Front	1		VACANT SITE	Plant
13	10025	MCNERNEY AV	Front	1		VACANT SITE	Plant
13	10119	MCNERNEY AV	Front	1		VACANT SITE	Plant
13	10222	MCNERNEY AV	Front	1		VACANT SITE	Plant
13	10247	MCNERNEY AV	Front	1		VACANT SITE	Plant
13	10336	MCNERNEY AV	Front	1		VACANT SITE	Plant
13	10353	MCNERNEY AV	Side	2	4225 X TENAYA AV	VACANT SITE	Plant
13	10408	MCNERNEY AV	Side	4	4260 X TENAYA AV	VACANT SITE	Plant
13	10409	MCNERNEY AV	Front	1		VACANT SITE	Plant
13	10409	MCNERNEY AV	Front	2		VACANT SITE	Plant
13	10409	MCNERNEY AV	Side	1	4230 X TENAYA AV	VACANT SITE	Plant
13	10531	MCNERNEY AV	Front	1		VACANT SITE	Plant
16	5800	MEADOW RD	Front	3		VACANT SITE	Plant
16	5807	MEADOW RD	Front	1		VACANT SITE	Plant
16	5811	MEADOW RD	Front	1		VACANT SITE	Plant
16	10705	MEADOW RD	Side	1	5810 X MEADOW RD	VACANT SITE	Plant
12	3274	MICHIGAN AV	Front	1		VACANT SITE	Plant
12	3284	MICHIGAN AV	Front	1		VACANT SITE	Plant

City of South Gate
Vacant Planting Sites - November 2007

DIST	HOUSE ADDRESS	SIDE	TREE	ON ADDRESS	COMMON NAME	MAINTENANCE
12	3290 MICHIGAN AV	Front	1		VACANT SITE	Plant
12	3294 MICHIGAN AV	Front	1		VACANT SITE	Plant
12	3297 MICHIGAN AV	Front	1		VACANT SITE	Plant
12	3363 MICHIGAN AV	Front	1		VACANT SITE	Plant
12	3469 MICHIGAN AV	Front	1		VACANT SITE	Plant
12	3475 MICHIGAN AV	Front	1		VACANT SITE	Plant
13	3525 MICHIGAN AV	Front	1		VACANT SITE	Plant
13	3742 MICHIGAN AV	Side	1	10201 X SAN GABRIEL AV	VACANT SITE	Plant
13	3825 MICHIGAN AV	Front	1		VACANT SITE	Plant
13	3825 MICHIGAN AV	Front	2		VACANT SITE	Plant
13	3825 MICHIGAN AV	Front	3		VACANT SITE	Plant
13	3910 MICHIGAN AV	Front	1		VACANT SITE	Plant
13	4009 MICHIGAN AV	Front	1		VACANT SITE	Plant
13	4028 MICHIGAN AV	Front	1		VACANT SITE	Plant
13	4210 MICHIGAN AV	Front	2		VACANT SITE	Plant
13	4215 MICHIGAN AV	Front	1		VACANT SITE	Plant
13	4300 MICHIGAN AV	Front	3		VACANT SITE	Plant
13	4321 MICHIGAN AV	Front	1		VACANT SITE	Plant
14	5006 MICHIGAN AV	Front	1		VACANT SITE	Plant
12	3277 MINNESOTA AV	Front	1		VACANT SITE	Plant
12	3300 MINNESOTA AV	Front	1		VACANT SITE	Plant
12	3305 MINNESOTA AV	Front	1		VACANT SITE	Plant
12	3308 MINNESOTA AV	Front	1		VACANT SITE	Plant
12	3317 MINNESOTA AV	Front	1		VACANT SITE	Plant
12	3324 MINNESOTA AV	Front	1		VACANT SITE	Plant
12	3325 MINNESOTA AV	Front	1		VACANT SITE	Plant
12	3353 MINNESOTA AV	Front	1		VACANT SITE	Plant
12	3365 X MINNESOTA AV	Front	2		VACANT SITE	Plant
12	3374 MINNESOTA AV	Side	3	10001 X ELIZABETH AV	VACANT SITE	Plant
5	2453 MISSOURI AV	Side	1	9636 X ALAMEDA ST	VACANT SITE	Plant
5	2463 MISSOURI AV	Front	1		VACANT SITE	Plant
5	2536 MISSOURI AV	Front	1		VACANT SITE	Plant

City of South Gate

Vacant Planting Sites - November 2007

DIST	HOUSE ADDRESS	SIDE	TREE	ON ADDRESS	COMMON NAME	MAINTENANCE
5	2544	MISSOURI AV	Front	1	VACANT SITE	Plant
5	2545	MISSOURI AV	Front	1	VACANT SITE	Plant
5	2580	MISSOURI AV	Front	1	VACANT SITE	Plant
5	2604	MISSOURI AV	Side	1 9700 X TRUBA AV	VACANT SITE	Plant
5	2619	MISSOURI AV	Front	1	VACANT SITE	Plant
5	2623	MISSOURI AV	Front	1	VACANT SITE	Plant
5	2634	MISSOURI AV	Front	1	VACANT SITE	Plant
5	2639	MISSOURI AV	Front	1	VACANT SITE	Plant
5	2703	MISSOURI AV	Front	1	VACANT SITE	Plant
5	2724	MISSOURI AV	Front	1	VACANT SITE	Plant
5	2728	MISSOURI AV	Front	1	VACANT SITE	Plant
5	2734	MISSOURI AV	Front	1	VACANT SITE	Plant
5	2815	MISSOURI AV	Front	1	VACANT SITE	Plant
5	2820	MISSOURI AV	Front	1	VACANT SITE	Plant
5	2825	MISSOURI AV	Front	1	VACANT SITE	Plant
5	2904	MISSOURI AV	Side	1 9700 X STANFORD AV	VACANT SITE	Plant
5	2914	MISSOURI AV	Front	1	VACANT SITE	Plant
5	2955	MISSOURI AV	Front	1	VACANT SITE	Plant
5	2958	MISSOURI AV	Front	1	VACANT SITE	Plant
8	3118	MISSOURI AV	Front	1	VACANT SITE	Plant
8	3123	MISSOURI AV	Front	1	VACANT SITE	Plant
8	3290	MISSOURI AV	Front	1	VACANT SITE	Plant
8	3355	MISSOURI AV	Front	1	VACANT SITE	Plant
8	3415	MISSOURI AV	Front	1	VACANT SITE	Plant
9	3517	MISSOURI AV	Front	1	VACANT SITE	Plant
9	3524	MISSOURI AV	Front	1	VACANT SITE	Plant
9	3709	MISSOURI AV	Front	1	VACANT SITE	Plant
9	3729	MISSOURI AV	Front	1	VACANT SITE	Plant
9	3730	MISSOURI AV	Front	1	VACANT SITE	Plant
9	3734	MISSOURI AV	Side	1 9701 X SAN GABRIEL AV	VACANT SITE	Plant
9	3820	MISSOURI AV	Front	1	VACANT SITE	Plant
9	3828	MISSOURI AV	Front	1	VACANT SITE	Plant

City of South Gate

Vacant Planting Sites - November 2007

DIST	HOUSE ADDRESS	SIDE	TREE	ON ADDRESS	COMMON NAME	MAINTENANCE
9	3916 MISSOURI AV	Front	1		VACANT SITE	Plant
9	3920 X MISSOURI AV	Front	1		VACANT SITE	Plant
9	3920 X MISSOURI AV	Front	2		VACANT SITE	Plant
9	4072 MISSOURI AV	Front	1		VACANT SITE	Plant
9	4173 MISSOURI AV	Front	1		VACANT SITE	Plant
9	4314 MISSOURI AV	Front	1		VACANT SITE	Plant
9	4320 MISSOURI AV	Front	1		VACANT SITE	Plant
10	4470 MISSOURI AV	Front	6		VACANT SITE	Plant
11	9941 MONTARA AV	Front	1		VACANT SITE	Plant
11	10037 MONTARA AV	Front	1		VACANT SITE	Plant
11	10043 MONTARA AV	Side	1	2951 X WISCONSIN AV	VACANT SITE	Plant
11	10132 MONTARA AV	Front	1		VACANT SITE	Plant
11	10207 MONTARA AV	Front	1		VACANT SITE	Plant
11	10218 MONTARA AV	Front	1		VACANT SITE	Plant
11	10242 MONTARA AV	Front	1		VACANT SITE	Plant
11	10353 MONTARA AV	Front	1		VACANT SITE	Plant
11	10408 MONTARA AV	Front	1		VACANT SITE	Plant
11	10459 MONTARA AV	Side	1	2885 X SEMINOLE AV	VACANT SITE	Plant
11	10606 MONTARA AV	Front	1		VACANT SITE	Plant
11	10618 MONTARA AV	Front	1		VACANT SITE	Plant
11	10619 MONTARA AV	Front	1		VACANT SITE	Plant
11	10625 MONTARA AV	Front	1		VACANT SITE	Plant
1	8110 MOUNTAIN VIEW AV	Front	1		VACANT SITE	Plant
1	8123 MOUNTAIN VIEW AV	Front	1		VACANT SITE	Plant
1	8133 MOUNTAIN VIEW AV	Front	1		VACANT SITE	Plant
1	8134 MOUNTAIN VIEW AV	Front	1		VACANT SITE	Plant
1	8147 MOUNTAIN VIEW AV	Front	1		VACANT SITE	Plant
1	8148 MOUNTAIN VIEW AV	Front	2		VACANT SITE	Plant
1	8153 MOUNTAIN VIEW AV	Front	1		VACANT SITE	Plant
1	8156 MOUNTAIN VIEW AV	Front	1		VACANT SITE	Plant
1	8189 X MOUNTAIN VIEW AV	Front	1		VACANT SITE	Plant
1	8414 MOUNTAIN VIEW AV	Front	1		VACANT SITE	Plant

City of South Gate

Vacant Planting Sites - November 2007

DIST	HOUSE ADDRESS	SIDE	TREE	ON ADDRESS	COMMON NAME	MAINTENANCE
1	8419 MOUNTAIN VIEW AV	Front	1		VACANT SITE	Plant
1	8425 MOUNTAIN VIEW AV	Front	1		VACANT SITE	Plant
1	8428 MOUNTAIN VIEW AV	Front	1		VACANT SITE	Plant
1	8429 MOUNTAIN VIEW AV	Front	1		VACANT SITE	Plant
1	8432 MOUNTAIN VIEW AV	Front	1		VACANT SITE	Plant
1	8433 MOUNTAIN VIEW AV	Front	1		VACANT SITE	Plant
1	8446 MOUNTAIN VIEW AV	Front	1		VACANT SITE	Plant
1	8449 MOUNTAIN VIEW AV	Front	1		VACANT SITE	Plant
1	8461 MOUNTAIN VIEW AV	Front	1		VACANT SITE	Plant
1	8475 MOUNTAIN VIEW AV	Front	1		VACANT SITE	Plant
1	8480 MOUNTAIN VIEW AV	Front	1		VACANT SITE	Plant
1	8480 MOUNTAIN VIEW AV	Side	1	2901 X INDEPENDENCE AV	VACANT SITE	Plant
1	8480 MOUNTAIN VIEW AV	Side	2	2901 X INDEPENDENCE AV	VACANT SITE	Plant
3	8605 MOUNTAIN VIEW AV	Front	2		VACANT SITE	Plant
3	8627 MOUNTAIN VIEW AV	Front	1		VACANT SITE	Plant
3	8634 MOUNTAIN VIEW AV	Front	1		VACANT SITE	Plant
3	8640 MOUNTAIN VIEW AV	Front	1		VACANT SITE	Plant
3	8644 MOUNTAIN VIEW AV	Front	1		VACANT SITE	Plant
3	8656 MOUNTAIN VIEW AV	Front	1		VACANT SITE	Plant
5	2500 X NEBRASKA AV	Front	1		VACANT SITE	Plant
5	2500 X NEBRASKA AV	Front	2		VACANT SITE	Plant
5	2500 X NEBRASKA AV	Front	3		VACANT SITE	Plant
5	2500 X NEBRASKA AV	Front	4		VACANT SITE	Plant
5	2550 X NEBRASKA AV	Front	1		VACANT SITE	Plant
5	2556 X NEBRASKA AV	Front	1		VACANT SITE	Plant
5	2556 X NEBRASKA AV	Front	2		VACANT SITE	Plant
5	2570 X NEBRASKA AV	Front	1		VACANT SITE	Plant
5	2570 X NEBRASKA AV	Front	2		VACANT SITE	Plant
5	2573 NEBRASKA AV	Front	1		VACANT SITE	Plant
5	2604 NEBRASKA AV	Front	1		VACANT SITE	Plant
5	2615 NEBRASKA AV	Front	1		VACANT SITE	Plant
5	2623 NEBRASKA AV	Front	1		VACANT SITE	Plant

City of South Gate
Vacant Planting Sites - November 2007

DIST	HOUSE ADDRESS	SIDE	TREE	ON ADDRESS	COMMON NAME	MAINTENANCE
5	2625 NEBRASKA AV	Front	1		VACANT SITE	Plant
5	2638 NEBRASKA AV	Front	1		VACANT SITE	Plant
5	2701 NEBRASKA AV	Front	1		VACANT SITE	Plant
5	2731 NEBRASKA AV	Front	1		VACANT SITE	Plant
5	2751 NEBRASKA AV	Front	1		VACANT SITE	Plant
5	2761 NEBRASKA AV	Front	1		VACANT SITE	Plant
5	2807 NEBRASKA AV	Front	1		VACANT SITE	Plant
5	2831 NEBRASKA AV	Front	3		VACANT SITE	Plant
5	2831 NEBRASKA AV	Side	1	9835 X STANFORD AV	VACANT SITE	Plant
5	2902 NEBRASKA AV	Side	1	9900 X STANFORD AV	VACANT SITE	Plant
5	2907 NEBRASKA AV	Front	1		VACANT SITE	Plant
5	2918 NEBRASKA AV	Front	1		VACANT SITE	Plant
5	2971 NEBRASKA AV	Front	1		VACANT SITE	Plant
5	3037 NEBRASKA AV	Front	1		VACANT SITE	Plant
5	3039 NEBRASKA AV	Front	1		VACANT SITE	Plant
17	5720 NEVADA AV	Side	2	5775 X CENTURY BL	VACANT SITE	Plant
17	5731 NEVADA AV	Side	1	12415 X CENTER ST	VACANT SITE	Plant
18	6020 NEVADA AV	Front	1		VACANT SITE	Plant
5	2471 OHIO AV	Front	1		VACANT SITE	Plant
5	2559 OHIO AV	Front	1		VACANT SITE	Plant
5	2564 OHIO AV	Front	1		VACANT SITE	Plant
5	2572 OHIO AV	Front	1		VACANT SITE	Plant
5	2585 OHIO AV	Side	1	9425 X TRUBA AV	VACANT SITE	Plant
5	2585 OHIO AV	Side	2	9425 X TRUBA AV	VACANT SITE	Plant
5	2603 OHIO AV	Side	1	9430 X TRUBA AV	VACANT SITE	Plant
5	2631 OHIO AV	Front	1		VACANT SITE	Plant
5	2710 OHIO AV	Front	1		VACANT SITE	Plant
5	2720 OHIO AV	Front	1		VACANT SITE	Plant
5	2955 X OHIO AV	Front	1		VACANT SITE	Plant
5	2955 X OHIO AV	Front	2		VACANT SITE	Plant
5	2955 X OHIO AV	Front	3		VACANT SITE	Plant
5	2955 X OHIO AV	Front	4		VACANT SITE	Plant

City of South Gate

Vacant Planting Sites - November 2007

DIST	HOUSE ADDRESS	SIDE	TREE	ON ADDRESS	COMMON NAME	MAINTENANCE
8	3105 OHIO AV	Front	1		VACANT SITE	Plant
8	3110 OHIO AV	Front	1		VACANT SITE	Plant
8	3170 OHIO AV	Front	1		VACANT SITE	Plant
17	11320 OKLAHOMA AV	Front	1		VACANT SITE	Plant
17	11321 OKLAHOMA AV	Front	1		VACANT SITE	Plant
17	11500 OKLAHOMA AV	Front	1		VACANT SITE	Plant
17	11610 OKLAHOMA AV	Front	1		VACANT SITE	Plant
17	11902 OKLAHOMA AV	Front	1		VACANT SITE	Plant
17	12106 OKLAHOMA AV	Front	1		VACANT SITE	Plant
17	12136 OKLAHOMA AV	Front	1		VACANT SITE	Plant
14	10008 ORANGE AV	Front	1		VACANT SITE	Plant
14	10120 ORANGE AV	Front	1		VACANT SITE	Plant
14	10121 ORANGE AV	Front	1		VACANT SITE	Plant
14	10129 ORANGE AV	Front	1		VACANT SITE	Plant
14	10136 ORANGE AV	Front	1		VACANT SITE	Plant
14	10136 ORANGE AV	Side	1	4845 X MICHIGAN AV	VACANT SITE	Plant
14	10136 ORANGE AV	Side	2	4845 X MICHIGAN AV	VACANT SITE	Plant
14	10137 ORANGE AV	Front	1		VACANT SITE	Plant
14	10206 ORANGE AV	Front	1		VACANT SITE	Plant
14	10206 ORANGE AV	Side	1	4840 X MICHIGAN AV	VACANT SITE	Plant
14	10207 ORANGE AV	Front	1		VACANT SITE	Plant
14	10230 ORANGE AV	Front	1		VACANT SITE	Plant
14	10235 ORANGE AV	Front	1		VACANT SITE	Plant
14	10304 ORANGE AV	Front	1		VACANT SITE	Plant
14	10305 X ORANGE AV	Front	1		VACANT SITE	Plant
14	10308 ORANGE AV	Front	1		VACANT SITE	Plant
14	10311 ORANGE AV	Front	1		VACANT SITE	Plant
14	10312 ORANGE AV	Front	1		VACANT SITE	Plant
14	10317 ORANGE AV	Front	1		VACANT SITE	Plant
14	10325 ORANGE AV	Front	1		VACANT SITE	Plant
14	10407 ORANGE AV	Front	1		VACANT SITE	Plant
14	10407 ORANGE AV	Side	1	4830 X TENAYA AV	VACANT SITE	Plant

City of South Gate
Vacant Planting Sites - November 2007

DIST	HOUSE ADDRESS	SIDE	TREE	ON ADDRESS	COMMON NAME	MAINTENANCE
14	10407 ORANGE AV	Side	2	4830 X TENAYA AV	VACANT SITE	Plant
14	10428 ORANGE AV	Front	1		VACANT SITE	Plant
14	10429 ORANGE AV	Front	1		VACANT SITE	Plant
14	10432 ORANGE AV	Front	1		VACANT SITE	Plant
14	10504 ORANGE AV	Front	1		VACANT SITE	Plant
14	10509 ORANGE AV	Front	1		VACANT SITE	Plant
5	2728 ORCHARD PL	Front	1		VACANT SITE	Plant
5	2729 ORCHARD PL	Front	1		VACANT SITE	Plant
5	2757 ORCHARD PL	Front	1		VACANT SITE	Plant
2	8400 OTIS ST	Side	1	4200 X LIBERTY BL	VACANT SITE	Plant
2	8400 OTIS ST	Side	3	4200 X LIBERTY BL	VACANT SITE	Plant
2	8407 OTIS ST	Side	1	4140 X LIBERTY BL	VACANT SITE	Plant
9	9418 OTIS ST	Side	1	4201 X DUANE WY	VACANT SITE	Plant
9	9643 OTIS ST	Side	1	4175 X MISSOURI AV	VACANT SITE	Plant
13	9926 OTIS ST	Front	1		VACANT SITE	Plant
13	9932 OTIS ST	Front	1		VACANT SITE	Plant
13	10001 OTIS ST	Front	1		VACANT SITE	Plant
13	10024 OTIS ST	Front	1		VACANT SITE	Plant
13	10106 OTIS ST	Front	1		VACANT SITE	Plant
13	10107 OTIS ST	Front	1		VACANT SITE	Plant
13	10119 OTIS ST	Front	1		VACANT SITE	Plant
13	10141 OTIS ST	Side	1	4125 X MICHIGAN AV	VACANT SITE	Plant
13	10141 OTIS ST	Side	2	4125 X MICHIGAN AV	VACANT SITE	Plant
13	10144 OTIS ST	Side	1	4201 X MICHIGAN AV	VACANT SITE	Plant
13	10200 OTIS ST	Front	1		VACANT SITE	Plant
13	10211 OTIS ST	Side	1	4120 X MICHIGAN AV	VACANT SITE	Plant
13	10215 OTIS ST	Front	1		VACANT SITE	Plant
13	10222 OTIS ST	Front	1		VACANT SITE	Plant
13	10223 OTIS ST	Front	1		VACANT SITE	Plant
13	10306 OTIS ST	Front	1		VACANT SITE	Plant
13	10307 OTIS ST	Front	1		VACANT SITE	Plant
13	10318 OTIS ST	Front	1		VACANT SITE	Plant

City of South Gate

Vacant Planting Sites - November 2007

DIST	HOUSE ADDRESS	SIDE	TREE	ON ADDRESS	COMMON NAME	MAINTENANCE
13	10325 OTIS ST	Front	1		VACANT SITE	Plant
13	10334 OTIS ST	Front	1		VACANT SITE	Plant
13	10342 OTIS ST	Front	1		VACANT SITE	Plant
13	10408 OTIS ST	Side	3	4200 X TENAYA AV	VACANT SITE	Plant
13	10426 OTIS ST	Front	1		VACANT SITE	Plant
13	10432 OTIS ST	Front	1		VACANT SITE	Plant
13	10526 OTIS ST	Front	1		VACANT SITE	Plant
13	10530 X OTIS ST	Front	1		VACANT SITE	Plant
13	10601 OTIS ST	Front	1		VACANT SITE	Plant
13	10606 OTIS ST	Front	1		VACANT SITE	Plant
13	10612 OTIS ST	Front	1		VACANT SITE	Plant
1	2648 PALM PL	Front	1		VACANT SITE	Plant
18	13067 PARAMOUNT BL	Side	1	6169 X MCKINLEY AV	VACANT SITE	Plant
18	13129 PARAMOUNT BL	Side	1	6165 X WILSON AV	VACANT SITE	Plant
18	13129 PARAMOUNT BL	Side	2	6165 X WILSON AV	VACANT SITE	Plant
18	13129 PARAMOUNT BL	Side	3	6160 X MCKINLEY AV	VACANT SITE	Plant
17	11343 PENNSYLVANIA AV	Front	1		VACANT SITE	Plant
17	11347 PENNSYLVANIA AV	Front	1		VACANT SITE	Plant
17	11352 PENNSYLVANIA AV	Front	1		VACANT SITE	Plant
17	11362 PENNSYLVANIA AV	Front	1		VACANT SITE	Plant
17	11373 PENNSYLVANIA AV	Front	1		VACANT SITE	Plant
17	11373 PENNSYLVANIA AV	Side	1	5525 X MONROE AV	VACANT SITE	Plant
17	11373 PENNSYLVANIA AV	Side	2	5525 X MONROE AV	VACANT SITE	Plant
17	11614 PENNSYLVANIA AV	Front	1		VACANT SITE	Plant
17	11621 PENNSYLVANIA AV	Front	1		VACANT SITE	Plant
17	11630 PENNSYLVANIA AV	Front	1		VACANT SITE	Plant
17	11702 PENNSYLVANIA AV	Front	1		VACANT SITE	Plant
17	11724 PENNSYLVANIA AV	Side	1	5565 X MCKINLEY AV	VACANT SITE	Plant
17	11724 PENNSYLVANIA AV	Side	2	5565 X MCKINLEY AV	VACANT SITE	Plant
17	11725 PENNSYLVANIA AV	Side	5	5525 X MCKINLEY AV	VACANT SITE	Plant
17	11800 PENNSYLVANIA AV	Side	2	5560 X MCKINLEY AV	VACANT SITE	Plant
17	11806 PENNSYLVANIA AV	Front	1		VACANT SITE	Plant

City of South Gate
Vacant Planting Sites - November 2007

DIST	HOUSE ADDRESS	SIDE	TREE	ON ADDRESS	COMMON NAME	MAINTENANCE	
17	11817	PENNSYLVANIA AV	Front	1		VACANT SITE	Plant
17	11823	PENNSYLVANIA AV	Front	1		VACANT SITE	Plant
17	11922	PENNSYLVANIA AV	Front	1		VACANT SITE	Plant
17	11923	PENNSYLVANIA AV	Front	1		VACANT SITE	Plant
17	12021	PENNSYLVANIA AV	Front	1		VACANT SITE	Plant
11	10127	PESCADERO AV	Front	1		VACANT SITE	Plant
11	10133	PESCADERO AV	Front	1		VACANT SITE	Plant
11	10138	PESCADERO AV	Front	1		VACANT SITE	Plant
11	10213	PESCADERO AV	Front	1		VACANT SITE	Plant
11	10248	PESCADERO AV	Front	1		VACANT SITE	Plant
11	10255	PESCADERO AV	Side	1	3025 X SEQUOIA DR	VACANT SITE	Plant
11	10308	PESCADERO AV	Side	1	3040 X SEQUOIA DR	VACANT SITE	Plant
11	10309	PESCADERO AV	Side	1	3030 X SEQUOIA DR	VACANT SITE	Plant
11	10321	PESCADERO AV	Front	1		VACANT SITE	Plant
11	10353	PESCADERO AV	Front	1		VACANT SITE	Plant
11	10400	PESCADERO AV	Front	1		VACANT SITE	Plant
11	10421	PESCADERO AV	Front	1		VACANT SITE	Plant
11	10433	PESCADERO AV	Front	1		VACANT SITE	Plant
11	10458	PESCADERO AV	Front	1		VACANT SITE	Plant
11	10458	PESCADERO AV	Side	1	2965 X SEMINOLE AV	VACANT SITE	Plant
11	10606	PESCADERO AV	Front	1		VACANT SITE	Plant
11	10613	PESCADERO AV	Front	1		VACANT SITE	Plant
11	10619	PESCADERO AV	Front	1		VACANT SITE	Plant
11	10625	PESCADERO AV	Front	1		VACANT SITE	Plant
1	2610	PINE PL	Front	1		VACANT SITE	Plant
1	2619	PINE PL	Front	1		VACANT SITE	Plant
1	2624	PINE PL	Front	1		VACANT SITE	Plant
1	2632	PINE PL	Front	1		VACANT SITE	Plant
1	2636	PINE PL	Front	1		VACANT SITE	Plant
1	2651	PINE PL	Front	1		VACANT SITE	Plant
1	2651	PINE PL	Front	2		VACANT SITE	Plant
14	9933	PINEHURST AV	Front	1		VACANT SITE	Plant

City of South Gate

Vacant Planting Sites - November 2007

DIST	HOUSE ADDRESS	SIDE	TREE	ON ADDRESS	COMMON NAME	MAINTENANCE
14	10000 X PINEHURST AV	Front	7		VACANT SITE	Plant
14	10000 X PINEHURST AV	Front	8		VACANT SITE	Plant
14	10126 PINEHURST AV	Front	1		VACANT SITE	Plant
14	10133 PINEHURST AV	Front	1		VACANT SITE	Plant
14	10133 PINEHURST AV	Side	1	4925 X MICHIGAN AV	VACANT SITE	Plant
14	10133 PINEHURST AV	Side	2	4925 X MICHIGAN AV	VACANT SITE	Plant
14	10133 PINEHURST AV	Side	3	4925 X MICHIGAN AV	VACANT SITE	Plant
14	10207 PINEHURST AV	Front	1		VACANT SITE	Plant
14	10207 PINEHURST AV	Side	1	4930 X MICHIGAN AV	VACANT SITE	Plant
14	10210 PINEHURST AV	Front	1		VACANT SITE	Plant
14	10211 PINEHURST AV	Front	1		VACANT SITE	Plant
14	10346 PINEHURST AV	Side	1	5001 X TENAYA AV	VACANT SITE	Plant
14	10346 PINEHURST AV	Side	2	5001 X TENAYA AV	VACANT SITE	Plant
14	10347 PINEHURST AV	Side	1	4925 X TENAYA AV	VACANT SITE	Plant
14	10406 PINEHURST AV	Side	1	5000 X TENAYA AV	VACANT SITE	Plant
14	10424 PINEHURST AV	Front	1		VACANT SITE	Plant
14	10428 PINEHURST AV	Front	1		VACANT SITE	Plant
1	2632 POPLAR PL	Front	1		VACANT SITE	Plant
1	2635 X POPLAR PL	Front	3		VACANT SITE	Plant
1	2646 POPLAR PL	Front	1		VACANT SITE	Plant
1	2652 POPLAR PL	Front	1		VACANT SITE	Plant
1	3172 POST ST	Front	1		VACANT SITE	Plant
1	3301 X POST ST	Front	1		VACANT SITE	Plant
1	3301 X POST ST	Front	2		VACANT SITE	Plant
1	3315 POST ST	Front	1		VACANT SITE	Plant
1	3327 POST ST	Front	1		VACANT SITE	Plant
1	3327 POST ST	Side	1	8415 X VICTORIA AV	VACANT SITE	Plant
16	5606 RAWLINGS AV	Front	1		VACANT SITE	Plant
16	5606 RAWLINGS AV	Front	2		VACANT SITE	Plant
16	5606 RAWLINGS AV	Front	3		VACANT SITE	Plant
16	5606 RAWLINGS AV	Side	1	11000 X PALMER AV	VACANT SITE	Plant
16	5622 RAWLINGS AV	Front	1		VACANT SITE	Plant

City of South Gate
Vacant Planting Sites - November 2007

DIST	HOUSE ADDRESS	SIDE	TREE	ON ADDRESS	COMMON NAME	MAINTENANCE
16	5626 RAWLINGS AV	Front	1		VACANT SITE	Plant
10	9500 RAYO AV	Front	1		VACANT SITE	Plant
10	9516 RAYO AV	Front	1		VACANT SITE	Plant
10	9516 RAYO AV	Front	2		VACANT SITE	Plant
16	10301 RENO AV	Front	1		VACANT SITE	Plant
16	10301 RENO AV	Side	2	10300 X KARMONT AV	VACANT SITE	Plant
16	10315 RENO AV	Front	1		VACANT SITE	Plant
16	10315 RENO AV	Front	2		VACANT SITE	Plant
16	10323 RENO AV	Front	1		VACANT SITE	Plant
16	10400 RENO AV	Side	2	5700 X BURNTWOOD ST	VACANT SITE	Plant
16	10407 RENO AV	Front	1		VACANT SITE	Plant
16	10441 RENO AV	Side	1	10420 X KARMONT AV	VACANT SITE	Plant
16	10441 RENO AV	Side	2	10420 X KARMONT AV	VACANT SITE	Plant
16	10200 RICHLEE AV	Front	1		VACANT SITE	Plant
16	10200 RICHLEE AV	Side	1	10210 X KARMONT AV	VACANT SITE	Plant
16	10206 RICHLEE AV	Front	1		VACANT SITE	Plant
16	10209 RICHLEE AV	Side	1	10236 X KARMONT AV	VACANT SITE	Plant
16	10216 RICHLEE AV	Front	1		VACANT SITE	Plant
16	10221 RICHLEE AV	Front	1		VACANT SITE	Plant
16	10222 RICHLEE AV	Front	1		VACANT SITE	Plant
16	10226 RICHLEE AV	Front	1		VACANT SITE	Plant
16	10232 RICHLEE AV	Front	1		VACANT SITE	Plant
16	10233 RICHLEE AV	Front	1		VACANT SITE	Plant
16	10236 RICHLEE AV	Front	1		VACANT SITE	Plant
16	10242 RICHLEE AV	Front	1		VACANT SITE	Plant
16	10305 RICHLEE AV	Front	1		VACANT SITE	Plant
16	10315 RICHLEE AV	Front	1		VACANT SITE	Plant
16	10318 RICHLEE AV	Front	1		VACANT SITE	Plant
16	10321 RICHLEE AV	Front	1		VACANT SITE	Plant
16	10322 RICHLEE AV	Front	1		VACANT SITE	Plant
16	10327 RICHLEE AV	Front	1		VACANT SITE	Plant
16	10328 RICHLEE AV	Front	1		VACANT SITE	Plant

City of South Gate

Vacant Planting Sites - November 2007

DIST	HOUSE ADDRESS	SIDE	TREE	ON ADDRESS	COMMON NAME	MAINTENANCE	
16	10332	RICHL EE AV	Front	1		VACANT SITE	Plant
16	10332	RICHL EE AV	Side	1	5745 X BURNTWOOD ST	VACANT SITE	Plant
16	10400	RICHL EE AV	Front	1		VACANT SITE	Plant
16	10406	RICHL EE AV	Front	1		VACANT SITE	Plant
16	10409	RICHL EE AV	Front	1		VACANT SITE	Plant
16	10421	RICHL EE AV	Front	1		VACANT SITE	Plant
16	10428	RICHL EE AV	Front	1		VACANT SITE	Plant
16	10431	RICHL EE AV	Front	1		VACANT SITE	Plant
16	10504	RICHL EE AV	Front	1		VACANT SITE	Plant
16	10548	RICHL EE AV	Front	1		VACANT SITE	Plant
16	10548	RICHL EE AV	Side	1	5701 X GLADY ST	VACANT SITE	Plant
16	10548	RICHL EE AV	Side	2	5701 X GLADY ST	VACANT SITE	Plant
17	5747	ROOSEVELT AV	Front	1		VACANT SITE	Plant
18	5909	ROOSEVELT AV	Front	1		VACANT SITE	Plant
18	5924	ROOSEVELT AV	Side	1	12001 X ARIZONA AV	VACANT SITE	Plant
18	5924	ROOSEVELT AV	Side	2	12001 X ARIZONA AV	VACANT SITE	Plant
18	5925	ROOSEVELT AV	Side	2	11925 X ARIZONA AV	VACANT SITE	Plant
18	6000	ROOSEVELT AV	Front	1		VACANT SITE	Plant
18	6006	ROOSEVELT AV	Front	1		VACANT SITE	Plant
18	6027	ROOSEVELT AV	Front	1		VACANT SITE	Plant
18	6032	ROOSEVELT AV	Front	1		VACANT SITE	Plant
18	6046	ROOSEVELT AV	Front	1		VACANT SITE	Plant
18	6062	ROOSEVELT AV	Front	1		VACANT SITE	Plant
18	6066	ROOSEVELT AV	Front	1		VACANT SITE	Plant
18	6100	ROOSEVELT AV	Side	1	12000 X HOOVER AV	VACANT SITE	Plant
18	6107	ROOSEVELT AV	Front	1		VACANT SITE	Plant
18	6120	ROOSEVELT AV	Front	1		VACANT SITE	Plant
18	6141	ROOSEVELT AV	Front	1		VACANT SITE	Plant
18	6146	ROOSEVELT AV	Front	1		VACANT SITE	Plant
18	6147	ROOSEVELT AV	Front	1		VACANT SITE	Plant
14	9924	ROSEWOOD AV	Front	1		VACANT SITE	Plant
14	9925	ROSEWOOD AV	Front	1		VACANT SITE	Plant

City of South Gate
Vacant Planting Sites - November 2007

DIST	HOUSE ADDRESS	SIDE	TREE	ON ADDRESS	COMMON NAME	MAINTENANCE
14	9928 ROSEWOOD AV	Front	1		VACANT SITE	Plant
14	9929 ROSEWOOD AV	Front	1		VACANT SITE	Plant
14	9932 ROSEWOOD AV	Front	1		VACANT SITE	Plant
14	10004 ROSEWOOD AV	Front	1		VACANT SITE	Plant
14	10008 ROSEWOOD AV	Front	1		VACANT SITE	Plant
14	10013 ROSEWOOD AV	Front	1		VACANT SITE	Plant
14	10100 ROSEWOOD AV	Front	1		VACANT SITE	Plant
14	10106 ROSEWOOD AV	Front	1		VACANT SITE	Plant
14	10108 ROSEWOOD AV	Front	1		VACANT SITE	Plant
14	10109 ROSEWOOD AV	Front	1		VACANT SITE	Plant
14	10113 ROSEWOOD AV	Front	1		VACANT SITE	Plant
14	10117 ROSEWOOD AV	Front	1		VACANT SITE	Plant
14	10121 ROSEWOOD AV	Front	1		VACANT SITE	Plant
14	10135 ROSEWOOD AV	Front	1		VACANT SITE	Plant
14	10136 X ROSEWOOD AV	Front	1		VACANT SITE	Plant
14	10207 ROSEWOOD AV	Front	1		VACANT SITE	Plant
14	10210 ROSEWOOD AV	Front	1		VACANT SITE	Plant
14	10213 ROSEWOOD AV	Front	1		VACANT SITE	Plant
14	10218 ROSEWOOD AV	Front	1		VACANT SITE	Plant
14	10219 ROSEWOOD AV	Front	1		VACANT SITE	Plant
14	10227 ROSEWOOD AV	Front	1		VACANT SITE	Plant
14	10234 ROSEWOOD AV	Front	1		VACANT SITE	Plant
14	10239 ROSEWOOD AV	Front	1		VACANT SITE	Plant
14	10243 ROSEWOOD AV	Front	1		VACANT SITE	Plant
14	10246 ROSEWOOD AV	Front	1		VACANT SITE	Plant
14	10300 ROSEWOOD AV	Front	1		VACANT SITE	Plant
14	10304 ROSEWOOD AV	Front	1		VACANT SITE	Plant
14	10312 ROSEWOOD AV	Front	1		VACANT SITE	Plant
14	10313 ROSEWOOD AV	Front	1		VACANT SITE	Plant
14	10316 ROSEWOOD AV	Front	1		VACANT SITE	Plant
14	10325 ROSEWOOD AV	Front	1		VACANT SITE	Plant
14	10328 ROSEWOOD AV	Front	1		VACANT SITE	Plant

City of South Gate

Vacant Planting Sites - November 2007

DIST	HOUSE ADDRESS	SIDE	TREE	ON ADDRESS	COMMON NAME	MAINTENANCE
14	10341 ROSEWOOD AV	Front	1		VACANT SITE	Plant
14	10346 ROSEWOOD AV	Side	1	4901 X TENAYA AV	VACANT SITE	Plant
14	10346 ROSEWOOD AV	Side	2	4901 X TENAYA AV	VACANT SITE	Plant
14	10347 ROSEWOOD AV	Side	3	4895 X TENAYA AV	VACANT SITE	Plant
14	10406 ROSEWOOD AV	Side	2	4900 X TENAYA AV	VACANT SITE	Plant
14	10407 ROSEWOOD AV	Side	1	4890 X TENAYA AV	VACANT SITE	Plant
14	10411 X ROSEWOOD AV	Front	1		VACANT SITE	Plant
14	10412 ROSEWOOD AV	Front	1		VACANT SITE	Plant
14	10425 ROSEWOOD AV	Front	1		VACANT SITE	Plant
14	10512 ROSEWOOD AV	Front	1		VACANT SITE	Plant
14	10516 ROSEWOOD AV	Front	1		VACANT SITE	Plant
14	10520 ROSEWOOD AV	Front	1		VACANT SITE	Plant
14	10525 ROSEWOOD AV	Front	1		VACANT SITE	Plant
14	10600 ROSEWOOD AV	Front	1		VACANT SITE	Plant
14	10407 SAINT JAMES AV	Front	1		VACANT SITE	Plant
14	10421 SAINT JAMES AV	Front	1		VACANT SITE	Plant
14	10429 SAINT JAMES AV	Front	1		VACANT SITE	Plant
14	10431 SAINT JAMES AV	Front	1		VACANT SITE	Plant
14	10433 SAINT JAMES AV	Front	1		VACANT SITE	Plant
14	10500 X SAINT JAMES AV	Front	3		VACANT SITE	Plant
14	10500 X SAINT JAMES AV	Front	4		VACANT SITE	Plant
14	10500 X SAINT JAMES AV	Front	5		VACANT SITE	Plant
14	10501 SAINT JAMES AV	Front	1		VACANT SITE	Plant
14	10521 SAINT JAMES AV	Front	1		VACANT SITE	Plant
14	10600 SAINT JAMES AV	Front	1		VACANT SITE	Plant
14	10706 SAINT JAMES AV	Front	1		VACANT SITE	Plant
14	10710 SAINT JAMES AV	Front	1		VACANT SITE	Plant
14	10717 SAINT JAMES AV	Front	1		VACANT SITE	Plant
14	10721 SAINT JAMES AV	Front	1		VACANT SITE	Plant
14	10748 SAINT JAMES AV	Side	3	5155 X PENDLETON AV	VACANT SITE	Plant
14	10749 SAINT JAMES AV	Side	1	5125 X PENDLETON AV	VACANT SITE	Plant
14	10800 SAINT JAMES AV	Side	1	5150 X PENDLETON AV	VACANT SITE	Plant

City of South Gate
Vacant Planting Sites - November 2007

DIST	HOUSE ADDRESS	SIDE	TREE	ON ADDRESS	COMMON NAME	MAINTENANCE
14	10800 SAINT JAMES AV	Side	2	5150 X PENDLETON AV	VACANT SITE	Plant
14	10806 SAINT JAMES AV	Front	1		VACANT SITE	Plant
14	10815 SAINT JAMES AV	Front	1		VACANT SITE	Plant
10	9637 SALT LAKE AV	Front	1		VACANT SITE	Plant
10	9721 SALT LAKE AV	Front	1		VACANT SITE	Plant
11	9925 SAN ANSELMO AV	Front	1		VACANT SITE	Plant
11	9932 SAN ANSELMO AV	Front	1		VACANT SITE	Plant
11	10001 SAN ANSELMO AV	Front	1		VACANT SITE	Plant
11	10015 SAN ANSELMO AV	Front	1		VACANT SITE	Plant
11	10024 SAN ANSELMO AV	Front	1		VACANT SITE	Plant
11	10031 SAN ANSELMO AV	Front	1		VACANT SITE	Plant
11	10036 SAN ANSELMO AV	Front	1		VACANT SITE	Plant
11	10106 SAN ANSELMO AV	Side	2	2960 X WISCONSIN AV	VACANT SITE	Plant
11	10111 SAN ANSELMO AV	Side	1	2930 X WISCONSIN AV	VACANT SITE	Plant
11	10115 SAN ANSELMO AV	Front	1		VACANT SITE	Plant
11	10120 SAN ANSELMO AV	Front	1		VACANT SITE	Plant
11	10124 SAN ANSELMO AV	Front	1		VACANT SITE	Plant
11	10141 SAN ANSELMO AV	Front	1		VACANT SITE	Plant
11	10144 SAN ANSELMO AV	Front	1		VACANT SITE	Plant
11	10150 SAN ANSELMO AV	Front	1		VACANT SITE	Plant
11	10210 SAN ANSELMO AV	Front	1		VACANT SITE	Plant
11	10218 SAN ANSELMO AV	Front	1		VACANT SITE	Plant
11	10231 SAN ANSELMO AV	Front	1		VACANT SITE	Plant
11	10242 SAN ANSELMO AV	Front	1		VACANT SITE	Plant
11	10254 SAN ANSELMO AV	Side	2	2935 X SEQUOIA DR	VACANT SITE	Plant
11	10255 SAN ANSELMO AV	Front	1		VACANT SITE	Plant
11	10332 SAN ANSELMO AV	Front	1		VACANT SITE	Plant
11	10347 SAN ANSELMO AV	Front	1		VACANT SITE	Plant
11	10353 SAN ANSELMO AV	Front	1		VACANT SITE	Plant
11	10358 SAN ANSELMO AV	Front	1		VACANT SITE	Plant
11	10359 SAN ANSELMO AV	Front	1		VACANT SITE	Plant
11	10400 SAN ANSELMO AV	Front	1		VACANT SITE	Plant

City of South Gate

Vacant Planting Sites - November 2007

DIST	HOUSE ADDRESS	SIDE	TREE	ON ADDRESS	COMMON NAME	MAINTENANCE	
11	10414	SAN ANSELMO AV	Front	1		VACANT SITE	Plant
11	10415	SAN ANSELMO AV	Front	1		VACANT SITE	Plant
11	10433	SAN ANSELMO AV	Front	1		VACANT SITE	Plant
11	10458	SAN ANSELMO AV	Front	1		VACANT SITE	Plant
11	10458	SAN ANSELMO AV	Side	2	2865 X SEMINOLE AV	VACANT SITE	Plant
11	10459	SAN ANSELMO AV	Front	1		VACANT SITE	Plant
11	10508	SAN ANSELMO AV	Side	1	2860 X SEMINOLE AV	VACANT SITE	Plant
11	10509	SAN ANSELMO AV	Side	2	2850 X SEMINOLE AV	VACANT SITE	Plant
11	10509	SAN ANSELMO AV	Side	3	2850 X SEMINOLE AV	VACANT SITE	Plant
11	10538	SAN ANSELMO AV	Front	1		VACANT SITE	Plant
11	10606	SAN ANSELMO AV	Front	1		VACANT SITE	Plant
11	10613	SAN ANSELMO AV	Front	1		VACANT SITE	Plant
11	10625	SAN ANSELMO AV	Front	1		VACANT SITE	Plant
2	8114	SAN ANTONIO AV	Front	1		VACANT SITE	Plant
2	8119	SAN ANTONIO AV	Front	1		VACANT SITE	Plant
2	8147	SAN ANTONIO AV	Front	1		VACANT SITE	Plant
2	8150	SAN ANTONIO AV	Front	1		VACANT SITE	Plant
2	8152	SAN ANTONIO AV	Front	1		VACANT SITE	Plant
2	8161	SAN ANTONIO AV	Front	1		VACANT SITE	Plant
2	8170	SAN ANTONIO AV	Front	1		VACANT SITE	Plant
2	8174	SAN ANTONIO AV	Front	1		VACANT SITE	Plant
2	8177	SAN ANTONIO AV	Front	1		VACANT SITE	Plant
2	8182	SAN ANTONIO AV	Front	1		VACANT SITE	Plant
2	8187	SAN ANTONIO AV	Front	1		VACANT SITE	Plant
2	8401	SAN ANTONIO AV	Front	1		VACANT SITE	Plant
2	8401	SAN ANTONIO AV	Front	2		VACANT SITE	Plant
2	8410	SAN ANTONIO AV	Front	1		VACANT SITE	Plant
2	8411	SAN ANTONIO AV	Front	1		VACANT SITE	Plant
2	8412	SAN ANTONIO AV	Front	1		VACANT SITE	Plant
2	8416	SAN ANTONIO AV	Front	1		VACANT SITE	Plant
2	8419	SAN ANTONIO AV	Front	1		VACANT SITE	Plant
2	8441	SAN ANTONIO AV	Front	1		VACANT SITE	Plant

City of South Gate
Vacant Planting Sites - November 2007

DIST	HOUSE ADDRESS	SIDE	TREE	ON ADDRESS	COMMON NAME	MAINTENANCE
2	8447 SAN ANTONIO AV	Front	1		VACANT SITE	Plant
2	8450 SAN ANTONIO AV	Front	1		VACANT SITE	Plant
2	8451 SAN ANTONIO AV	Front	1		VACANT SITE	Plant
2	8464 SAN ANTONIO AV	Front	1		VACANT SITE	Plant
2	8475 SAN ANTONIO AV	Front	1		VACANT SITE	Plant
2	8479 SAN ANTONIO AV	Front	1		VACANT SITE	Plant
4	8601 SAN ANTONIO AV	Front	1		VACANT SITE	Plant
4	8601 SAN ANTONIO AV	Front	2		VACANT SITE	Plant
4	8601 SAN ANTONIO AV	Front	4		VACANT SITE	Plant
4	8601 SAN ANTONIO AV	Front	5		VACANT SITE	Plant
4	8601 SAN ANTONIO AV	Front	6		VACANT SITE	Plant
4	8601 SAN ANTONIO AV	Front	7		VACANT SITE	Plant
4	8601 SAN ANTONIO AV	Front	8		VACANT SITE	Plant
4	8601 SAN ANTONIO AV	Front	9		VACANT SITE	Plant
4	8601 SAN ANTONIO AV	Front	10		VACANT SITE	Plant
4	8601 SAN ANTONIO AV	Front	11		VACANT SITE	Plant
4	8654 SAN ANTONIO AV	Front	1		VACANT SITE	Plant
4	8664 SAN ANTONIO AV	Front	1		VACANT SITE	Plant
4	8668 SAN ANTONIO AV	Front	1		VACANT SITE	Plant
4	8676 X SAN ANTONIO AV	Front	1		VACANT SITE	Plant
4	8685 SAN ANTONIO AV	Front	1		VACANT SITE	Plant
4	8688 X SAN ANTONIO AV	Front	1		VACANT SITE	Plant
7	8911 SAN ANTONIO AV	Front	1		VACANT SITE	Plant
7	8918 SAN ANTONIO AV	Front	1		VACANT SITE	Plant
7	8926 SAN ANTONIO AV	Front	1		VACANT SITE	Plant
7	8935 SAN ANTONIO AV	Front	1		VACANT SITE	Plant
7	8944 SAN ANTONIO AV	Front	1		VACANT SITE	Plant
7	8966 SAN ANTONIO AV	Front	1		VACANT SITE	Plant
7	8967 SAN ANTONIO AV	Front	1		VACANT SITE	Plant
7	8976 SAN ANTONIO AV	Front	1		VACANT SITE	Plant
7	8978 SAN ANTONIO AV	Front	1		VACANT SITE	Plant
7	8980 SAN ANTONIO AV	Front	1		VACANT SITE	Plant

City of South Gate

Vacant Planting Sites - November 2007

DIST	HOUSE ADDRESS	SIDE	TREE	ON ADDRESS	COMMON NAME	MAINTENANCE	
7	8993	SAN ANTONIO AV	Front	1	VACANT SITE	Plant	
9	9207	SAN ANTONIO AV	Front	1	VACANT SITE	Plant	
9	9208	SAN ANTONIO AV	Front	1	VACANT SITE	Plant	
9	9215	SAN ANTONIO AV	Front	1	VACANT SITE	Plant	
9	9237	SAN ANTONIO AV	Front	1	VACANT SITE	Plant	
9	9238	SAN ANTONIO AV	Front	1	VACANT SITE	Plant	
9	9327	SAN ANTONIO AV	Front	1	VACANT SITE	Plant	
9	9336	SAN ANTONIO AV	Front	1	VACANT SITE	Plant	
9	9405	SAN ANTONIO AV	Front	1	VACANT SITE	Plant	
9	9520	SAN ANTONIO AV	Front	1	VACANT SITE	Plant	
9	9529	SAN ANTONIO AV	Front	1	VACANT SITE	Plant	
9	9537 X	SAN ANTONIO AV	Front	1	VACANT SITE	Plant	
9	9547	SAN ANTONIO AV	Front	1	VACANT SITE	Plant	
9	9555	SAN ANTONIO AV	Front	1	VACANT SITE	Plant	
9	9620	SAN ANTONIO AV	Front	1	VACANT SITE	Plant	
9	9644	SAN ANTONIO AV	Side	1	3601 X MISSOURI AV	VACANT SITE	Plant
9	9715	SAN ANTONIO AV	Front	1	VACANT SITE	Plant	
9	9722 X	SAN ANTONIO AV	Front	2	VACANT SITE	Plant	
9	9723	SAN ANTONIO AV	Front	1	VACANT SITE	Plant	
9	9726 X	SAN ANTONIO AV	Front	1	VACANT SITE	Plant	
9	9740	SAN ANTONIO AV	Front	1	VACANT SITE	Plant	
9	9800	SAN ANTONIO AV	Front	1	VACANT SITE	Plant	
9	9823	SAN ANTONIO AV	Front	2	VACANT SITE	Plant	
9	9832	SAN ANTONIO AV	Front	1	VACANT SITE	Plant	
9	9837	SAN ANTONIO AV	Front	1	VACANT SITE	Plant	
13	9927	SAN ANTONIO AV	Front	4	VACANT SITE	Plant	
13	9927	SAN ANTONIO AV	Front	5	VACANT SITE	Plant	
13	9932	SAN ANTONIO AV	Front	1	VACANT SITE	Plant	
13	10004	SAN ANTONIO AV	Front	1	VACANT SITE	Plant	
13	10028	SAN ANTONIO AV	Front	1	VACANT SITE	Plant	
13	10113	SAN ANTONIO AV	Front	1	VACANT SITE	Plant	
13	10121	SAN ANTONIO AV	Front	1	VACANT SITE	Plant	

City of South Gate
Vacant Planting Sites - November 2007

DIST	HOUSE ADDRESS	SIDE	TREE	ON ADDRESS	COMMON NAME	MAINTENANCE	
13	10133	SAN ANTONIO AV	Front	1		VACANT SITE	Plant
13	10211	SAN ANTONIO AV	Front	2		VACANT SITE	Plant
13	10212	SAN ANTONIO AV	Front	1		VACANT SITE	Plant
13	10251	SAN ANTONIO AV	Front	2		VACANT SITE	Plant
13	10254	SAN ANTONIO AV	Front	1		VACANT SITE	Plant
13	10255	SAN ANTONIO AV	Front	1		VACANT SITE	Plant
13	10301	SAN ANTONIO AV	Front	1		VACANT SITE	Plant
13	10305	SAN ANTONIO AV	Front	1		VACANT SITE	Plant
13	10309	SAN ANTONIO AV	Front	1		VACANT SITE	Plant
13	10312	SAN ANTONIO AV	Front	1		VACANT SITE	Plant
13	10318	SAN ANTONIO AV	Front	1		VACANT SITE	Plant
13	10321	SAN ANTONIO AV	Front	1		VACANT SITE	Plant
13	10360	SAN ANTONIO AV	Side	1	3601 X TENAYA AV	VACANT SITE	Plant
13	10361	SAN ANTONIO AV	Side	2	3525 X TENAYA AV	VACANT SITE	Plant
13	10403	SAN ANTONIO AV	Side	1	3530 X TENAYA AV	VACANT SITE	Plant
13	10406	SAN ANTONIO AV	Side	1	3600 X TENAYA AV	VACANT SITE	Plant
13	10406	SAN ANTONIO AV	Side	2	3600 X TENAYA AV	VACANT SITE	Plant
13	10406	SAN ANTONIO AV	Side	3	3600 X TENAYA AV	VACANT SITE	Plant
13	10508	SAN ANTONIO AV	Front	1		VACANT SITE	Plant
13	10511	SAN ANTONIO AV	Front	1		VACANT SITE	Plant
13	10521	SAN ANTONIO AV	Front	1		VACANT SITE	Plant
13	10600 X	SAN ANTONIO AV	Front	2		VACANT SITE	Plant
13	10611	SAN ANTONIO AV	Front	1		VACANT SITE	Plant
2	8109	SAN CARLOS AV	Front	1		VACANT SITE	Plant
2	8121	SAN CARLOS AV	Front	1		VACANT SITE	Plant
2	8124	SAN CARLOS AV	Front	1		VACANT SITE	Plant
2	8128	SAN CARLOS AV	Front	1		VACANT SITE	Plant
2	8137	SAN CARLOS AV	Front	1		VACANT SITE	Plant
2	8150	SAN CARLOS AV	Front	1		VACANT SITE	Plant
2	8177	SAN CARLOS AV	Front	1		VACANT SITE	Plant
2	8180	SAN CARLOS AV	Front	1		VACANT SITE	Plant
2	8181	SAN CARLOS AV	Front	1		VACANT SITE	Plant

City of South Gate

Vacant Planting Sites - November 2007

DIST	HOUSE ADDRESS	SIDE	TREE	ON ADDRESS	COMMON NAME	MAINTENANCE
2	8192 SAN CARLOS AV	Side	1	3701 X LIBERTY BL	VACANT SITE	Plant
2	8415 SAN CARLOS AV	Front	1		VACANT SITE	Plant
2	8424 SAN CARLOS AV	Front	1		VACANT SITE	Plant
2	8428 SAN CARLOS AV	Front	1		VACANT SITE	Plant
2	8439 SAN CARLOS AV	Front	1		VACANT SITE	Plant
2	8440 SAN CARLOS AV	Front	1		VACANT SITE	Plant
2	8447 SAN CARLOS AV	Front	1		VACANT SITE	Plant
2	8451 SAN CARLOS AV	Front	1		VACANT SITE	Plant
2	8457 SAN CARLOS AV	Front	1		VACANT SITE	Plant
2	8481 SAN CARLOS AV	Side	1	3625 X INDEPENDENCE AV	VACANT SITE	Plant
4	8603 SAN CARLOS AV	Front	1		VACANT SITE	Plant
4	8603 SAN CARLOS AV	Side	1	3620 X ARDMORE AV	VACANT SITE	Plant
4	8606 SAN CARLOS AV	Front	1		VACANT SITE	Plant
4	8607 SAN CARLOS AV	Front	1		VACANT SITE	Plant
4	8608 SAN CARLOS AV	Front	1		VACANT SITE	Plant
4	8615 SAN CARLOS AV	Front	1		VACANT SITE	Plant
4	8620 SAN CARLOS AV	Front	1		VACANT SITE	Plant
4	8624 SAN CARLOS AV	Front	1		VACANT SITE	Plant
4	8625 SAN CARLOS AV	Front	1		VACANT SITE	Plant
4	8628 SAN CARLOS AV	Front	1		VACANT SITE	Plant
4	8633 SAN CARLOS AV	Front	1		VACANT SITE	Plant
4	8641 SAN CARLOS AV	Front	1		VACANT SITE	Plant
4	8645 SAN CARLOS AV	Front	1		VACANT SITE	Plant
4	8648 SAN CARLOS AV	Front	1		VACANT SITE	Plant
4	8653 SAN CARLOS AV	Front	1		VACANT SITE	Plant
4	8656 SAN CARLOS AV	Front	1		VACANT SITE	Plant
4	8657 SAN CARLOS AV	Front	1		VACANT SITE	Plant
4	8660 SAN CARLOS AV	Front	1		VACANT SITE	Plant
4	8661 SAN CARLOS AV	Front	1		VACANT SITE	Plant
4	8664 SAN CARLOS AV	Front	1		VACANT SITE	Plant
4	8672 SAN CARLOS AV	Front	1		VACANT SITE	Plant
4	8673 SAN CARLOS AV	Front	1		VACANT SITE	Plant

City of South Gate
Vacant Planting Sites - November 2007

DIST	HOUSE ADDRESS	SIDE	TREE	ON ADDRESS	COMMON NAME	MAINTENANCE
4	8676 SAN CARLOS AV	Front	1		VACANT SITE	Plant
4	8681 SAN CARLOS AV	Front	1		VACANT SITE	Plant
4	8684 SAN CARLOS AV	Front	1		VACANT SITE	Plant
4	8689 SAN CARLOS AV	Front	1		VACANT SITE	Plant
4	8692 SAN CARLOS AV	Front	1		VACANT SITE	Plant
4	8693 SAN CARLOS AV	Front	1		VACANT SITE	Plant
7	8915 SAN CARLOS AV	Front	1		VACANT SITE	Plant
7	8937 SAN CARLOS AV	Front	1		VACANT SITE	Plant
7	8949 SAN CARLOS AV	Front	1		VACANT SITE	Plant
7	8960 SAN CARLOS AV	Front	1		VACANT SITE	Plant
7	8987 SAN CARLOS AV	Front	1		VACANT SITE	Plant
7	8995 SAN CARLOS AV	Front	1		VACANT SITE	Plant
9	9206 SAN CARLOS AV	Front	1		VACANT SITE	Plant
9	9213 SAN CARLOS AV	Front	1		VACANT SITE	Plant
9	9228 SAN CARLOS AV	Front	1		VACANT SITE	Plant
9	9310 SAN CARLOS AV	Front	1		VACANT SITE	Plant
9	9330 SAN CARLOS AV	Front	1		VACANT SITE	Plant
9	9333 SAN CARLOS AV	Front	1		VACANT SITE	Plant
9	9412 SAN CARLOS AV	Front	1		VACANT SITE	Plant
9	9420 SAN CARLOS AV	Front	1		VACANT SITE	Plant
9	9500 SAN CARLOS AV	Side	1	3700 X DUANE WY	VACANT SITE	Plant
9	9500 SAN CARLOS AV	Side	2	3700 X DUANE WY	VACANT SITE	Plant
9	9519 SAN CARLOS AV	Front	1		VACANT SITE	Plant
9	9533 SAN CARLOS AV	Front	1		VACANT SITE	Plant
9	9534 SAN CARLOS AV	Front	1		VACANT SITE	Plant
9	9536 SAN CARLOS AV	Front	1		VACANT SITE	Plant
9	9543 SAN CARLOS AV	Front	1		VACANT SITE	Plant
9	9547 SAN CARLOS AV	Front	1		VACANT SITE	Plant
9	9615 SAN CARLOS AV	Front	1		VACANT SITE	Plant
9	9645 SAN CARLOS AV	Side	1	3655 X MISSOURI AV	VACANT SITE	Plant
9	9645 SAN CARLOS AV	Side	2	3655 X MISSOURI AV	VACANT SITE	Plant
9	9700 SAN CARLOS AV	Side	1	3700 X MISSOURI AV	VACANT SITE	Plant

City of South Gate

Vacant Planting Sites - November 2007

DIST	HOUSE ADDRESS	SIDE	TREE	ON ADDRESS	COMMON NAME	MAINTENANCE	
9	9700	SAN CARLOS AV	Side	2	3700 X MISSOURI AV	VACANT SITE	Plant
9	9700	SAN CARLOS AV	Side	3	3700 X MISSOURI AV	VACANT SITE	Plant
9	9723	SAN CARLOS AV	Front	1		VACANT SITE	Plant
9	9726	SAN CARLOS AV	Front	1		VACANT SITE	Plant
9	9727	SAN CARLOS AV	Front	1		VACANT SITE	Plant
9	9734	SAN CARLOS AV	Front	1		VACANT SITE	Plant
9	9739	SAN CARLOS AV	Front	1		VACANT SITE	Plant
9	9808	SAN CARLOS AV	Front	1		VACANT SITE	Plant
9	9811	SAN CARLOS AV	Front	1		VACANT SITE	Plant
9	9815	SAN CARLOS AV	Front	1		VACANT SITE	Plant
9	9817	SAN CARLOS AV	Front	1		VACANT SITE	Plant
9	9821	SAN CARLOS AV	Front	1		VACANT SITE	Plant
9	9828	SAN CARLOS AV	Front	1		VACANT SITE	Plant
9	9833	SAN CARLOS AV	Front	1		VACANT SITE	Plant
13	10005	SAN CARLOS AV	Front	1		VACANT SITE	Plant
13	10009	SAN CARLOS AV	Front	1		VACANT SITE	Plant
13	10013	SAN CARLOS AV	Front	1		VACANT SITE	Plant
13	10024	SAN CARLOS AV	Front	1		VACANT SITE	Plant
13	10025	SAN CARLOS AV	Front	1		VACANT SITE	Plant
13	10028	SAN CARLOS AV	Front	1		VACANT SITE	Plant
13	10037	SAN CARLOS AV	Front	1		VACANT SITE	Plant
13	10105	SAN CARLOS AV	Front	2		VACANT SITE	Plant
13	10119	SAN CARLOS AV	Front	1		VACANT SITE	Plant
13	10133	SAN CARLOS AV	Front	1		VACANT SITE	Plant
13	10142	SAN CARLOS AV	Side	1	3701 X MICHIGAN AV	VACANT SITE	Plant
13	10201	SAN CARLOS AV	Front	1		VACANT SITE	Plant
13	10201	SAN CARLOS AV	Front	2		VACANT SITE	Plant
13	10201	SAN CARLOS AV	Side	1	3630 X MICHIGAN AV	VACANT SITE	Plant
13	10206	SAN CARLOS AV	Front	1		VACANT SITE	Plant
13	10235	SAN CARLOS AV	Front	1		VACANT SITE	Plant
13	10245	SAN CARLOS AV	Front	1		VACANT SITE	Plant
13	10300	SAN CARLOS AV	Front	1		VACANT SITE	Plant

City of South Gate
Vacant Planting Sites - November 2007

DIST	HOUSE ADDRESS	SIDE	TREE	ON ADDRESS	COMMON NAME	MAINTENANCE	
13	10304	SAN CARLOS AV	Front	1		VACANT SITE	Plant
13	10308	SAN CARLOS AV	Front	1		VACANT SITE	Plant
13	10313	SAN CARLOS AV	Front	1		VACANT SITE	Plant
13	10313	SAN CARLOS AV	Front	2		VACANT SITE	Plant
13	10313	SAN CARLOS AV	Front	3		VACANT SITE	Plant
13	10320	SAN CARLOS AV	Front	1		VACANT SITE	Plant
13	10321	SAN CARLOS AV	Front	1		VACANT SITE	Plant
13	10324	SAN CARLOS AV	Front	1		VACANT SITE	Plant
13	10329	SAN CARLOS AV	Front	1		VACANT SITE	Plant
13	10335	SAN CARLOS AV	Front	1		VACANT SITE	Plant
13	10345	SAN CARLOS AV	Front	1		VACANT SITE	Plant
13	10360	SAN CARLOS AV	Front	1		VACANT SITE	Plant
13	10360	SAN CARLOS AV	Side	1	3701 X TENAYA AV	VACANT SITE	Plant
13	10361	SAN CARLOS AV	Front	1		VACANT SITE	Plant
13	10361	SAN CARLOS AV	Side	1	3625 X TENAYA AV	VACANT SITE	Plant
13	10406	SAN CARLOS AV	Side	1	3700 X TENAYA AV	VACANT SITE	Plant
13	10406	SAN CARLOS AV	Side	2	3700 X TENAYA AV	VACANT SITE	Plant
13	10411	SAN CARLOS AV	Front	1		VACANT SITE	Plant
13	10411	SAN CARLOS AV	Side	1	3630 X TENAYA AV	VACANT SITE	Plant
13	10417	SAN CARLOS AV	Front	1		VACANT SITE	Plant
13	10427	SAN CARLOS AV	Front	1		VACANT SITE	Plant
13	10438	SAN CARLOS AV	Front	1		VACANT SITE	Plant
13	10439	SAN CARLOS AV	Front	1		VACANT SITE	Plant
13	10501	SAN CARLOS AV	Front	1		VACANT SITE	Plant
13	10505	SAN CARLOS AV	Front	1		VACANT SITE	Plant
13	10529	SAN CARLOS AV	Front	1		VACANT SITE	Plant
13	10540	SAN CARLOS AV	Front	1		VACANT SITE	Plant
13	10609	SAN CARLOS AV	Front	1		VACANT SITE	Plant
13	10612	SAN CARLOS AV	Front	1		VACANT SITE	Plant
13	10615	SAN CARLOS AV	Front	1		VACANT SITE	Plant
2	8124	SAN GABRIEL AV	Front	1		VACANT SITE	Plant
2	8180	SAN GABRIEL AV	Front	1		VACANT SITE	Plant

City of South Gate

Vacant Planting Sites - November 2007

DIST	HOUSE ADDRESS	SIDE	TREE	ON ADDRESS	COMMON NAME	MAINTENANCE
2	8409 SAN GABRIEL AV	Front	1		VACANT SITE	Plant
2	8413 SAN GABRIEL AV	Front	1		VACANT SITE	Plant
2	8417 SAN GABRIEL AV	Front	1		VACANT SITE	Plant
2	8420 SAN GABRIEL AV	Front	1		VACANT SITE	Plant
2	8459 SAN GABRIEL AV	Front	1		VACANT SITE	Plant
2	8464 SAN GABRIEL AV	Front	1		VACANT SITE	Plant
2	8465 SAN GABRIEL AV	Front	1		VACANT SITE	Plant
4	8611 SAN GABRIEL AV	Front	1		VACANT SITE	Plant
4	8615 SAN GABRIEL AV	Front	1		VACANT SITE	Plant
4	8625 SAN GABRIEL AV	Front	1		VACANT SITE	Plant
4	8631 SAN GABRIEL AV	Front	1		VACANT SITE	Plant
4	8637 SAN GABRIEL AV	Front	1		VACANT SITE	Plant
4	8641 SAN GABRIEL AV	Front	1		VACANT SITE	Plant
4	8645 SAN GABRIEL AV	Front	1		VACANT SITE	Plant
4	8649 SAN GABRIEL AV	Front	1		VACANT SITE	Plant
4	8653 SAN GABRIEL AV	Front	1		VACANT SITE	Plant
4	8657 SAN GABRIEL AV	Front	1		VACANT SITE	Plant
4	8661 SAN GABRIEL AV	Front	1		VACANT SITE	Plant
4	8665 SAN GABRIEL AV	Front	1		VACANT SITE	Plant
4	8674 SAN GABRIEL AV	Front	1		VACANT SITE	Plant
4	8675 SAN GABRIEL AV	Front	1		VACANT SITE	Plant
4	8680 SAN GABRIEL AV	Front	1		VACANT SITE	Plant
4	8685 SAN GABRIEL AV	Front	1		VACANT SITE	Plant
7	8916 SAN GABRIEL AV	Front	1		VACANT SITE	Plant
7	8928 SAN GABRIEL AV	Front	1		VACANT SITE	Plant
7	8946 SAN GABRIEL AV	Front	1		VACANT SITE	Plant
7	8949 SAN GABRIEL AV	Front	1		VACANT SITE	Plant
7	8961 SAN GABRIEL AV	Front	1		VACANT SITE	Plant
7	8973 SAN GABRIEL AV	Front	1		VACANT SITE	Plant
7	8980 SAN GABRIEL AV	Front	1		VACANT SITE	Plant
7	8984 SAN GABRIEL AV	Front	1		VACANT SITE	Plant
7	8995 SAN GABRIEL AV	Front	1		VACANT SITE	Plant

City of South Gate
Vacant Planting Sites - November 2007

DIST	HOUSE ADDRESS	SIDE	TREE	ON ADDRESS	COMMON NAME	MAINTENANCE	
7	9001	SAN GABRIEL AV	Front	1		VACANT SITE	Plant
9	9214	SAN GABRIEL AV	Front	1		VACANT SITE	Plant
9	9215	SAN GABRIEL AV	Front	1		VACANT SITE	Plant
9	9225	SAN GABRIEL AV	Front	1		VACANT SITE	Plant
9	9230	SAN GABRIEL AV	Front	1		VACANT SITE	Plant
9	9303	SAN GABRIEL AV	Front	1		VACANT SITE	Plant
9	9307	SAN GABRIEL AV	Front	1		VACANT SITE	Plant
9	9311	SAN GABRIEL AV	Front	1		VACANT SITE	Plant
9	9316	SAN GABRIEL AV	Front	1		VACANT SITE	Plant
9	9324	SAN GABRIEL AV	Front	1		VACANT SITE	Plant
9	9400	SAN GABRIEL AV	Front	1		VACANT SITE	Plant
9	9412	SAN GABRIEL AV	Front	1		VACANT SITE	Plant
9	9617	SAN GABRIEL AV	Front	1		VACANT SITE	Plant
9	9635	SAN GABRIEL AV	Front	1		VACANT SITE	Plant
9	9643	SAN GABRIEL AV	Front	1		VACANT SITE	Plant
9	9700	SAN GABRIEL AV	Side	1	3800 X MISSOURI AV	VACANT SITE	Plant
9	9706	SAN GABRIEL AV	Front	1		VACANT SITE	Plant
9	9715	SAN GABRIEL AV	Front	1		VACANT SITE	Plant
9	9716	SAN GABRIEL AV	Front	1		VACANT SITE	Plant
9	9723	SAN GABRIEL AV	Front	1		VACANT SITE	Plant
9	9726	SAN GABRIEL AV	Front	1		VACANT SITE	Plant
9	9735	SAN GABRIEL AV	Front	1		VACANT SITE	Plant
9	9812 X	SAN GABRIEL AV	Front	1		VACANT SITE	Plant
9	9817	SAN GABRIEL AV	Front	3		VACANT SITE	Plant
9	9824	SAN GABRIEL AV	Front	1		VACANT SITE	Plant
9	9829	SAN GABRIEL AV	Front	1		VACANT SITE	Plant
9	9830	SAN GABRIEL AV	Front	1		VACANT SITE	Plant
9	9836	SAN GABRIEL AV	Front	1		VACANT SITE	Plant
9	9837	SAN GABRIEL AV	Front	1		VACANT SITE	Plant
13	10008	SAN GABRIEL AV	Front	1		VACANT SITE	Plant
13	10020	SAN GABRIEL AV	Front	1		VACANT SITE	Plant
13	10100	SAN GABRIEL AV	Front	1		VACANT SITE	Plant

City of South Gate

Vacant Planting Sites - November 2007

DIST	HOUSE ADDRESS	SIDE	TREE	ON ADDRESS	COMMON NAME	MAINTENANCE	
13	10113	SAN GABRIEL AV	Front	1		VACANT SITE	Plant
13	10126	SAN GABRIEL AV	Front	1		VACANT SITE	Plant
13	10132	SAN GABRIEL AV	Front	1		VACANT SITE	Plant
13	10206	SAN GABRIEL AV	Side	1	3800 X MICHIGAN AV	VACANT SITE	Plant
13	10227	SAN GABRIEL AV	Front	1		VACANT SITE	Plant
13	10229	SAN GABRIEL AV	Front	1		VACANT SITE	Plant
13	10252	SAN GABRIEL AV	Front	1		VACANT SITE	Plant
13	10309	SAN GABRIEL AV	Front	1		VACANT SITE	Plant
13	10310	SAN GABRIEL AV	Front	1		VACANT SITE	Plant
13	10322	SAN GABRIEL AV	Front	1		VACANT SITE	Plant
13	10338	SAN GABRIEL AV	Front	1		VACANT SITE	Plant
13	10344	SAN GABRIEL AV	Front	1		VACANT SITE	Plant
13	10360	SAN GABRIEL AV	Side	1	3801 X TENAYA AV	VACANT SITE	Plant
13	10360	SAN GABRIEL AV	Side	2	3801 X TENAYA AV	VACANT SITE	Plant
13	10420	SAN GABRIEL AV	Front	1		VACANT SITE	Plant
13	10423	SAN GABRIEL AV	Front	1		VACANT SITE	Plant
13	10515	SAN GABRIEL AV	Front	1		VACANT SITE	Plant
13	10605	SAN GABRIEL AV	Front	2		VACANT SITE	Plant
13	10613	SAN GABRIEL AV	Front	1		VACANT SITE	Plant
11	10100 X	SAN JOSE AV	Front	1		VACANT SITE	Plant
11	10129	SAN JOSE AV	Front	1		VACANT SITE	Plant
11	10134	SAN JOSE AV	Front	1		VACANT SITE	Plant
11	10204	SAN JOSE AV	Front	1		VACANT SITE	Plant
11	10255	SAN JOSE AV	Front	1		VACANT SITE	Plant
11	10514	SAN JOSE AV	Front	1		VACANT SITE	Plant
11	10533	SAN JOSE AV	Front	1		VACANT SITE	Plant
11	10542	SAN JOSE AV	Side	1	3135 X TECUMSEH AV	VACANT SITE	Plant
11	10542	SAN JOSE AV	Side	2	3135 X TECUMSEH AV	VACANT SITE	Plant
11	10624	SAN JOSE AV	Front	1		VACANT SITE	Plant
2	8125	SAN JUAN AV	Front	1		VACANT SITE	Plant
2	8126	SAN JUAN AV	Front	1		VACANT SITE	Plant
2	8129	SAN JUAN AV	Front	1		VACANT SITE	Plant

City of South Gate
Vacant Planting Sites - November 2007

DIST	HOUSE ADDRESS	SIDE	TREE	ON ADDRESS	COMMON NAME	MAINTENANCE
2	8134 SAN JUAN AV	Front	1		VACANT SITE	Plant
2	8141 SAN JUAN AV	Front	1		VACANT SITE	Plant
2	8142 SAN JUAN AV	Front	1		VACANT SITE	Plant
2	8151 SAN JUAN AV	Front	1		VACANT SITE	Plant
2	8152 SAN JUAN AV	Front	1		VACANT SITE	Plant
2	8153 SAN JUAN AV	Front	1		VACANT SITE	Plant
2	8157 SAN JUAN AV	Front	1		VACANT SITE	Plant
2	8168 SAN JUAN AV	Front	1		VACANT SITE	Plant
2	8172 SAN JUAN AV	Front	1		VACANT SITE	Plant
2	8185 SAN JUAN AV	Front	1		VACANT SITE	Plant
2	8417 SAN JUAN AV	Front	1		VACANT SITE	Plant
2	8425 SAN JUAN AV	Front	1		VACANT SITE	Plant
2	8468 SAN JUAN AV	Front	1		VACANT SITE	Plant
4	8601 X SAN JUAN AV	Front	4		VACANT SITE	Plant
4	8602 SAN JUAN AV	Side	1	3900 X ARDMORE AV	VACANT SITE	Plant
4	8606 SAN JUAN AV	Front	1		VACANT SITE	Plant
4	8624 SAN JUAN AV	Front	1		VACANT SITE	Plant
4	8628 SAN JUAN AV	Front	1		VACANT SITE	Plant
4	8636 SAN JUAN AV	Front	1		VACANT SITE	Plant
4	8672 SAN JUAN AV	Front	1		VACANT SITE	Plant
7	8916 SAN JUAN AV	Front	1		VACANT SITE	Plant
7	8920 SAN JUAN AV	Front	1		VACANT SITE	Plant
7	8928 SAN JUAN AV	Front	1		VACANT SITE	Plant
7	8929 SAN JUAN AV	Front	1		VACANT SITE	Plant
7	8935 SAN JUAN AV	Front	1		VACANT SITE	Plant
7	8943 SAN JUAN AV	Front	1		VACANT SITE	Plant
7	8946 SAN JUAN AV	Front	1		VACANT SITE	Plant
7	8964 SAN JUAN AV	Front	1		VACANT SITE	Plant
7	8981 SAN JUAN AV	Front	1		VACANT SITE	Plant
9	9223 SAN JUAN AV	Front	1		VACANT SITE	Plant
9	9234 SAN JUAN AV	Front	1		VACANT SITE	Plant
9	9300 SAN JUAN AV	Front	1		VACANT SITE	Plant

City of South Gate

Vacant Planting Sites - November 2007

DIST	HOUSE ADDRESS	SIDE	TREE	ON ADDRESS	COMMON NAME	MAINTENANCE
9	9313	SAN JUAN AV	Front	1	VACANT SITE	Plant
9	9320	SAN JUAN AV	Front	1	VACANT SITE	Plant
9	9412	SAN JUAN AV	Front	1	VACANT SITE	Plant
9	9412	SAN JUAN AV	Side	1 3901 X DUANE WY	VACANT SITE	Plant
9	9512	SAN JUAN AV	Front	1	VACANT SITE	Plant
9	9513	SAN JUAN AV	Front	1	VACANT SITE	Plant
9	9515	SAN JUAN AV	Front	1	VACANT SITE	Plant
9	9526	SAN JUAN AV	Front	1	VACANT SITE	Plant
9	9540	SAN JUAN AV	Front	1	VACANT SITE	Plant
9	9541	SAN JUAN AV	Front	1	VACANT SITE	Plant
9	9545	SAN JUAN AV	Front	1	VACANT SITE	Plant
9	9609	SAN JUAN AV	Front	1	VACANT SITE	Plant
9	9612	SAN JUAN AV	Front	1	VACANT SITE	Plant
9	9616	SAN JUAN AV	Front	1	VACANT SITE	Plant
9	9621	SAN JUAN AV	Front	1	VACANT SITE	Plant
9	9706	SAN JUAN AV	Side	1 3900 X MISSOURI AV	VACANT SITE	Plant
9	9707	SAN JUAN AV	Side	1 3840 X MISSOURI AV	VACANT SITE	Plant
9	9719	SAN JUAN AV	Front	1	VACANT SITE	Plant
9	9723	SAN JUAN AV	Front	1	VACANT SITE	Plant
9	9727	SAN JUAN AV	Front	1	VACANT SITE	Plant
9	9808	SAN JUAN AV	Front	1	VACANT SITE	Plant
9	9811	SAN JUAN AV	Front	1	VACANT SITE	Plant
9	9812	SAN JUAN AV	Front	1	VACANT SITE	Plant
9	9815	SAN JUAN AV	Front	1	VACANT SITE	Plant
9	9816	SAN JUAN AV	Front	1	VACANT SITE	Plant
9	9820	SAN JUAN AV	Front	1	VACANT SITE	Plant
13	10115	SAN JUAN AV	Front	1	VACANT SITE	Plant
13	10120	SAN JUAN AV	Front	1	VACANT SITE	Plant
13	10127	SAN JUAN AV	Front	1	VACANT SITE	Plant
13	10218	SAN JUAN AV	Front	1	VACANT SITE	Plant
13	10245	SAN JUAN AV	Front	1	VACANT SITE	Plant
13	10251	SAN JUAN AV	Front	1	VACANT SITE	Plant

City of South Gate
Vacant Planting Sites - November 2007

DIST	HOUSE ADDRESS	SIDE	TREE	ON ADDRESS	COMMON NAME	MAINTENANCE
13	10315 SAN JUAN AV	Front	1		VACANT SITE	Plant
13	10349 SAN JUAN AV	Side	1	3835 X TENAYA AV	VACANT SITE	Plant
13	10352 SAN JUAN AV	Side	1	3901 X TENAYA AV	VACANT SITE	Plant
13	10352 SAN JUAN AV	Side	2	3901 X TENAYA AV	VACANT SITE	Plant
13	10526 SAN JUAN AV	Front	1		VACANT SITE	Plant
13	10527 SAN JUAN AV	Front	2		VACANT SITE	Plant
2	8110 SAN LUIS AV	Front	1		VACANT SITE	Plant
2	8115 SAN LUIS AV	Front	1		VACANT SITE	Plant
2	8129 SAN LUIS AV	Front	1		VACANT SITE	Plant
2	8129 SAN LUIS AV	Front	2		VACANT SITE	Plant
2	8133 SAN LUIS AV	Front	1		VACANT SITE	Plant
2	8134 SAN LUIS AV	Front	1		VACANT SITE	Plant
2	8146 SAN LUIS AV	Front	1		VACANT SITE	Plant
2	8148 SAN LUIS AV	Front	1		VACANT SITE	Plant
2	8170 SAN LUIS AV	Front	1		VACANT SITE	Plant
2	8178 SAN LUIS AV	Front	1		VACANT SITE	Plant
2	8182 SAN LUIS AV	Front	1		VACANT SITE	Plant
2	8413 SAN LUIS AV	Front	1		VACANT SITE	Plant
2	8417 SAN LUIS AV	Front	1		VACANT SITE	Plant
2	8420 SAN LUIS AV	Front	1		VACANT SITE	Plant
2	8441 SAN LUIS AV	Front	1		VACANT SITE	Plant
2	8453 SAN LUIS AV	Front	1		VACANT SITE	Plant
2	8460 SAN LUIS AV	Front	1		VACANT SITE	Plant
2	8461 SAN LUIS AV	Front	1		VACANT SITE	Plant
2	8472 SAN LUIS AV	Front	1		VACANT SITE	Plant
2	8478 SAN LUIS AV	Front	1		VACANT SITE	Plant
2	8479 SAN LUIS AV	Side	2	3925 X INDEPENDENCE AV	VACANT SITE	Plant
4	8606 SAN LUIS AV	Front	1		VACANT SITE	Plant
4	8614 SAN LUIS AV	Front	1		VACANT SITE	Plant
4	8615 SAN LUIS AV	Front	1		VACANT SITE	Plant
4	8619 SAN LUIS AV	Front	1		VACANT SITE	Plant
4	8620 SAN LUIS AV	Front	1		VACANT SITE	Plant

City of South Gate

Vacant Planting Sites - November 2007

DIST	HOUSE ADDRESS	SIDE	TREE	ON ADDRESS	COMMON NAME	MAINTENANCE
4	8625 SAN LUIS AV	Front	1		VACANT SITE	Plant
4	8628 SAN LUIS AV	Front	1		VACANT SITE	Plant
4	8649 SAN LUIS AV	Front	1		VACANT SITE	Plant
4	8656 SAN LUIS AV	Front	1		VACANT SITE	Plant
4	8661 SAN LUIS AV	Front	1		VACANT SITE	Plant
4	8664 SAN LUIS AV	Front	1		VACANT SITE	Plant
4	8668 SAN LUIS AV	Front	1		VACANT SITE	Plant
4	8673 SAN LUIS AV	Front	1		VACANT SITE	Plant
4	8681 SAN LUIS AV	Front	1		VACANT SITE	Plant
4	8685 SAN LUIS AV	Front	1		VACANT SITE	Plant
4	8692 SAN LUIS AV	Front	1		VACANT SITE	Plant
7	8915 SAN LUIS AV	Front	1		VACANT SITE	Plant
7	8916 SAN LUIS AV	Front	1		VACANT SITE	Plant
7	8919 SAN LUIS AV	Front	1		VACANT SITE	Plant
7	8921 SAN LUIS AV	Front	1		VACANT SITE	Plant
7	8925 SAN LUIS AV	Front	1		VACANT SITE	Plant
7	8928 SAN LUIS AV	Front	2		VACANT SITE	Plant
7	8929 SAN LUIS AV	Front	1		VACANT SITE	Plant
7	8932 SAN LUIS AV	Front	1		VACANT SITE	Plant
7	8940 SAN LUIS AV	Front	1		VACANT SITE	Plant
7	8948 SAN LUIS AV	Front	1		VACANT SITE	Plant
7	8969 SAN LUIS AV	Front	1		VACANT SITE	Plant
7	8973 SAN LUIS AV	Front	1		VACANT SITE	Plant
7	8986 SAN LUIS AV	Front	1		VACANT SITE	Plant
7	8990 SAN LUIS AV	Front	1		VACANT SITE	Plant
7	8995 SAN LUIS AV	Front	1		VACANT SITE	Plant
9	9228 SAN LUIS AV	Front	1		VACANT SITE	Plant
9	9232 SAN LUIS AV	Front	2		VACANT SITE	Plant
9	9320 SAN LUIS AV	Front	1		VACANT SITE	Plant
9	9322 SAN LUIS AV	Front	1		VACANT SITE	Plant
9	9326 SAN LUIS AV	Front	1		VACANT SITE	Plant
9	9508 SAN LUIS AV	Front	1		VACANT SITE	Plant

City of South Gate
Vacant Planting Sites - November 2007

DIST	HOUSE ADDRESS	SIDE	TREE	ON ADDRESS	COMMON NAME	MAINTENANCE
9	9512 SAN LUIS AV	Front	1		VACANT SITE	Plant
9	9512 SAN LUIS AV	Front	2		VACANT SITE	Plant
9	9513 SAN LUIS AV	Front	1		VACANT SITE	Plant
13	10101 SAN LUIS AV	Front	1		VACANT SITE	Plant
13	10115 SAN LUIS AV	Front	1		VACANT SITE	Plant
13	10120 SAN LUIS AV	Front	1		VACANT SITE	Plant
13	10140 SAN LUIS AV	Front	1		VACANT SITE	Plant
13	10140 SAN LUIS AV	Side	2	4001 X MICHIGAN AV	VACANT SITE	Plant
13	10201 SAN LUIS AV	Side	2	3930 X MICHIGAN AV	VACANT SITE	Plant
13	10210 SAN LUIS AV	Side	1	4000 X MICHIGAN AV	VACANT SITE	Plant
13	10250 SAN LUIS AV	Front	1		VACANT SITE	Plant
13	10311 SAN LUIS AV	Front	1		VACANT SITE	Plant
13	10317 SAN LUIS AV	Front	1		VACANT SITE	Plant
13	10351 SAN LUIS AV	Side	1	3935 X TENAYA AV	VACANT SITE	Plant
13	10351 SAN LUIS AV	Side	2	3935 X TENAYA AV	VACANT SITE	Plant
13	10404 SAN LUIS AV	Side	4	4000 X TENAYA AV	VACANT SITE	Plant
13	10405 SAN LUIS AV	Side	1	3940 X TENAYA AV	VACANT SITE	Plant
2	8115 SAN MIGUEL AV	Front	1		VACANT SITE	Plant
2	8128 SAN MIGUEL AV	Front	1		VACANT SITE	Plant
2	8156 SAN MIGUEL AV	Front	1		VACANT SITE	Plant
2	8163 SAN MIGUEL AV	Front	1		VACANT SITE	Plant
2	8167 SAN MIGUEL AV	Front	1		VACANT SITE	Plant
2	8177 SAN MIGUEL AV	Front	1		VACANT SITE	Plant
2	8186 SAN MIGUEL AV	Front	1		VACANT SITE	Plant
2	8190 SAN MIGUEL AV	Front	1		VACANT SITE	Plant
2	8190 SAN MIGUEL AV	Front	2		VACANT SITE	Plant
2	8190 SAN MIGUEL AV	Side	1	4055 X LIBERTY BL	VACANT SITE	Plant
2	8417 SAN MIGUEL AV	Front	1		VACANT SITE	Plant
2	8418 SAN MIGUEL AV	Front	1		VACANT SITE	Plant
2	8421 SAN MIGUEL AV	Front	1		VACANT SITE	Plant
2	8425 SAN MIGUEL AV	Front	1		VACANT SITE	Plant
2	8426 SAN MIGUEL AV	Front	1		VACANT SITE	Plant

City of South Gate

Vacant Planting Sites - November 2007

DIST	HOUSE ADDRESS	SIDE	TREE	ON ADDRESS	COMMON NAME	MAINTENANCE	
2	8429	SAN MIGUEL AV	Front	1		VACANT SITE	Plant
2	8444	SAN MIGUEL AV	Front	1		VACANT SITE	Plant
2	8451	SAN MIGUEL AV	Front	1		VACANT SITE	Plant
2	8455	SAN MIGUEL AV	Front	1		VACANT SITE	Plant
2	8463	SAN MIGUEL AV	Front	1		VACANT SITE	Plant
2	8464	SAN MIGUEL AV	Front	1		VACANT SITE	Plant
4	8600	SAN MIGUEL AV	Side	1	4060 X ARDMORE AV	VACANT SITE	Plant
4	8600	SAN MIGUEL AV	Side	2	4060 X ARDMORE AV	VACANT SITE	Plant
4	8600	SAN MIGUEL AV	Side	3	4060 X ARDMORE AV	VACANT SITE	Plant
4	8603	SAN MIGUEL AV	Side	1	4030 X ARDMORE AV	VACANT SITE	Plant
4	8612	SAN MIGUEL AV	Front	1		VACANT SITE	Plant
4	8620	SAN MIGUEL AV	Front	1		VACANT SITE	Plant
4	8639	SAN MIGUEL AV	Front	1		VACANT SITE	Plant
4	8643	SAN MIGUEL AV	Front	1		VACANT SITE	Plant
4	8644	SAN MIGUEL AV	Front	1		VACANT SITE	Plant
4	8648	SAN MIGUEL AV	Front	1		VACANT SITE	Plant
4	8651	SAN MIGUEL AV	Front	1		VACANT SITE	Plant
4	8662	SAN MIGUEL AV	Front	1		VACANT SITE	Plant
4	8663	SAN MIGUEL AV	Front	1		VACANT SITE	Plant
4	8677	SAN MIGUEL AV	Front	1		VACANT SITE	Plant
4	8685	SAN MIGUEL AV	Front	1		VACANT SITE	Plant
4	8689	SAN MIGUEL AV	Front	1		VACANT SITE	Plant
7	8923	SAN MIGUEL AV	Front	1		VACANT SITE	Plant
7	8925	SAN MIGUEL AV	Front	1		VACANT SITE	Plant
7	8931	SAN MIGUEL AV	Front	1		VACANT SITE	Plant
7	8935	SAN MIGUEL AV	Front	1		VACANT SITE	Plant
7	8939	SAN MIGUEL AV	Front	1		VACANT SITE	Plant
7	8941	SAN MIGUEL AV	Front	1		VACANT SITE	Plant
7	8945	SAN MIGUEL AV	Front	1		VACANT SITE	Plant
7	8951	SAN MIGUEL AV	Front	1		VACANT SITE	Plant
7	8961	SAN MIGUEL AV	Front	1		VACANT SITE	Plant
7	8965	SAN MIGUEL AV	Front	1		VACANT SITE	Plant

City of South Gate

Vacant Planting Sites - November 2007

DIST	HOUSE ADDRESS	SIDE	TREE	ON ADDRESS	COMMON NAME	MAINTENANCE
7	8971 SAN MIGUEL AV	Front	1		VACANT SITE	Plant
7	8973 SAN MIGUEL AV	Front	1		VACANT SITE	Plant
7	8977 SAN MIGUEL AV	Front	1		VACANT SITE	Plant
7	8985 SAN MIGUEL AV	Front	1		VACANT SITE	Plant
7	8991 SAN MIGUEL AV	Front	1		VACANT SITE	Plant
7	8997 SAN MIGUEL AV	Front	1		VACANT SITE	Plant
7	9001 SAN MIGUEL AV	Front	1		VACANT SITE	Plant
7	9203 SAN MIGUEL AV	Side	1	4020 X SOUTHERN AV	VACANT SITE	Plant
9	9206 SAN MIGUEL AV	Front	1		VACANT SITE	Plant
9	9207 SAN MIGUEL AV	Front	1		VACANT SITE	Plant
9	9210 SAN MIGUEL AV	Front	1		VACANT SITE	Plant
9	9226 SAN MIGUEL AV	Front	1		VACANT SITE	Plant
9	9231 SAN MIGUEL AV	Front	1		VACANT SITE	Plant
9	9231 SAN MIGUEL AV	Front	2		VACANT SITE	Plant
9	9300 SAN MIGUEL AV	Front	1		VACANT SITE	Plant
9	9301 SAN MIGUEL AV	Front	1		VACANT SITE	Plant
9	9301 SAN MIGUEL AV	Front	2		VACANT SITE	Plant
9	9303 SAN MIGUEL AV	Front	1		VACANT SITE	Plant
9	9304 SAN MIGUEL AV	Front	1		VACANT SITE	Plant
9	9308 SAN MIGUEL AV	Front	1		VACANT SITE	Plant
9	9320 SAN MIGUEL AV	Front	1		VACANT SITE	Plant
9	9336 SAN MIGUEL AV	Front	1		VACANT SITE	Plant
9	9400 SAN MIGUEL AV	Front	1		VACANT SITE	Plant
9	9408 SAN MIGUEL AV	Front	1		VACANT SITE	Plant
9	9408 SAN MIGUEL AV	Front	2		VACANT SITE	Plant
9	9505 SAN MIGUEL AV	Front	1		VACANT SITE	Plant
9	9513 SAN MIGUEL AV	Front	1		VACANT SITE	Plant
9	9517 SAN MIGUEL AV	Front	1		VACANT SITE	Plant
9	9550 SAN MIGUEL AV	Front	1		VACANT SITE	Plant
9	9604 SAN MIGUEL AV	Front	1		VACANT SITE	Plant
9	9612 SAN MIGUEL AV	Front	1		VACANT SITE	Plant
9	9616 SAN MIGUEL AV	Front	1		VACANT SITE	Plant

City of South Gate

Vacant Planting Sites - November 2007

DIST	HOUSE ADDRESS	SIDE	TREE	ON ADDRESS	COMMON NAME	MAINTENANCE
9	9640 SAN MIGUEL AV	Front	2		VACANT SITE	Plant
9	9706 SAN MIGUEL AV	Side	1	4060 X MISSOURI AV	VACANT SITE	Plant
9	9710 SAN MIGUEL AV	Front	1		VACANT SITE	Plant
9	9722 SAN MIGUEL AV	Front	1		VACANT SITE	Plant
13	9932 SAN MIGUEL AV	Front	1		VACANT SITE	Plant
13	10004 SAN MIGUEL AV	Front	1		VACANT SITE	Plant
13	10011 SAN MIGUEL AV	Front	1		VACANT SITE	Plant
13	10019 SAN MIGUEL AV	Front	1		VACANT SITE	Plant
13	10025 SAN MIGUEL AV	Front	1		VACANT SITE	Plant
13	10029 SAN MIGUEL AV	Front	1		VACANT SITE	Plant
13	10109 SAN MIGUEL AV	Front	1		VACANT SITE	Plant
13	10141 SAN MIGUEL AV	Side	1	4025 X MICHIGAN AV	VACANT SITE	Plant
13	10211 SAN MIGUEL AV	Front	1		VACANT SITE	Plant
13	10334 SAN MIGUEL AV	Front	1		VACANT SITE	Plant
13	10348 SAN MIGUEL AV	Side	1	4055 X TENAYA AV	VACANT SITE	Plant
13	10348 SAN MIGUEL AV	Side	2	4055 X TENAYA AV	VACANT SITE	Plant
13	10348 SAN MIGUEL AV	Side	3	4055 X TENAYA AV	VACANT SITE	Plant
13	10349 SAN MIGUEL AV	Side	2	4025 X TENAYA AV	VACANT SITE	Plant
13	10405 SAN MIGUEL AV	Side	1	4020 X TENAYA AV	VACANT SITE	Plant
13	10405 SAN MIGUEL AV	Side	2	4020 X TENAYA AV	VACANT SITE	Plant
13	10432 SAN MIGUEL AV	Front	1		VACANT SITE	Plant
13	10532 SAN MIGUEL AV	Front	1		VACANT SITE	Plant
13	10533 SAN MIGUEL AV	Front	1		VACANT SITE	Plant
13	10606 SAN MIGUEL AV	Front	1		VACANT SITE	Plant
13	10614 X SAN MIGUEL AV	Front	1		VACANT SITE	Plant
2	8141 SAN VINCENTE AV	Front	1		VACANT SITE	Plant
2	8148 SAN VINCENTE AV	Front	1		VACANT SITE	Plant
2	8414 SAN VINCENTE AV	Front	1		VACANT SITE	Plant
2	8422 SAN VINCENTE AV	Front	1		VACANT SITE	Plant
2	8423 SAN VINCENTE AV	Front	1		VACANT SITE	Plant
2	8426 SAN VINCENTE AV	Front	1		VACANT SITE	Plant
2	8430 SAN VINCENTE AV	Front	1		VACANT SITE	Plant

City of South Gate
Vacant Planting Sites - November 2007

DIST	HOUSE ADDRESS	SIDE	TREE	ON ADDRESS	COMMON NAME	MAINTENANCE	
2	8437	SAN VINCENTE AV	Front	1		VACANT SITE	Plant
2	8446	SAN VINCENTE AV	Front	1		VACANT SITE	Plant
2	8454	SAN VINCENTE AV	Front	1		VACANT SITE	Plant
2	8466	SAN VINCENTE AV	Front	1		VACANT SITE	Plant
2	8477	SAN VINCENTE AV	Side	1	4025 X INDEPENDENCE AV	VACANT SITE	Plant
9	9530	SAN VINCENTE AV	Front	1		VACANT SITE	Plant
9	9548	SAN VINCENTE AV	Front	1		VACANT SITE	Plant
9	9624	SAN VINCENTE AV	Front	1		VACANT SITE	Plant
9	9632	SAN VINCENTE AV	Front	1		VACANT SITE	Plant
9	9644	SAN VINCENTE AV	Front	1		VACANT SITE	Plant
9	9706	SAN VINCENTE AV	Side	2	4100 X MISSOURI AV	VACANT SITE	Plant
9	9706	SAN VINCENTE AV	Side	3	4100 X MISSOURI AV	VACANT SITE	Plant
9	9707	SAN VINCENTE AV	Side	1	4080 X MISSOURI AV	VACANT SITE	Plant
9	9709	SAN VINCENTE AV	Front	1		VACANT SITE	Plant
9	9722	SAN VINCENTE AV	Front	1		VACANT SITE	Plant
9	9735	SAN VINCENTE AV	Front	1		VACANT SITE	Plant
9	9811	SAN VINCENTE AV	Front	1		VACANT SITE	Plant
9	9825	SAN VINCENTE AV	Front	1		VACANT SITE	Plant
9	9829	SAN VINCENTE AV	Front	1		VACANT SITE	Plant
9	9833	SAN VINCENTE AV	Front	1		VACANT SITE	Plant
9	9837	SAN VINCENTE AV	Front	1		VACANT SITE	Plant
13	9939	SAN VINCENTE AV	Front	1		VACANT SITE	Plant
13	10015	SAN VINCENTE AV	Front	1		VACANT SITE	Plant
13	10030	SAN VINCENTE AV	Front	1		VACANT SITE	Plant
13	10033	SAN VINCENTE AV	Front	1		VACANT SITE	Plant
13	10100	SAN VINCENTE AV	Front	1		VACANT SITE	Plant
13	10112	SAN VINCENTE AV	Front	1		VACANT SITE	Plant
13	10117	SAN VINCENTE AV	Front	1		VACANT SITE	Plant
13	10118	SAN VINCENTE AV	Front	1		VACANT SITE	Plant
13	10140	SAN VINCENTE AV	Side	3	4091 X MICHIGAN AV	VACANT SITE	Plant
13	10239	SAN VINCENTE AV	Front	1		VACANT SITE	Plant
13	10246	SAN VINCENTE AV	Front	1		VACANT SITE	Plant

City of South Gate

Vacant Planting Sites - November 2007

DIST	HOUSE ADDRESS	SIDE	TREE	ON ADDRESS	COMMON NAME	MAINTENANCE	
13	10247	SAN VINCENTE AV	Front	1		VACANT SITE	Plant
13	10300	SAN VINCENTE AV	Front	1		VACANT SITE	Plant
13	10327	SAN VINCENTE AV	Front	1		VACANT SITE	Plant
13	10352	SAN VINCENTE AV	Front	1		VACANT SITE	Plant
13	10352	SAN VINCENTE AV	Side	2	4145 X TENAYA AV	VACANT SITE	Plant
13	10352	SAN VINCENTE AV	Side	3	4145 X TENAYA AV	VACANT SITE	Plant
13	10405	SAN VINCENTE AV	Side	1	4070 X TENAYA AV	VACANT SITE	Plant
13	10420	SAN VINCENTE AV	Front	1		VACANT SITE	Plant
13	10438	SAN VINCENTE AV	Front	1		VACANT SITE	Plant
13	10603	SAN VINCENTE AV	Front	1		VACANT SITE	Plant
1	2700 X	SANTA ANA ST	Front	2		VACANT SITE	Plant
1	2700 X	SANTA ANA ST	Front	4		VACANT SITE	Plant
1	2804	SANTA ANA ST	Front	1		VACANT SITE	Plant
1	2804	SANTA ANA ST	Side	1	8100 X BEECHWOOD AV	VACANT SITE	Plant
1	2906	SANTA ANA ST	Front	1		VACANT SITE	Plant
1	2926	SANTA ANA ST	Side	1	8101 X CHESTNUT AV	VACANT SITE	Plant
1	2926	SANTA ANA ST	Side	2	8101 X CHESTNUT AV	VACANT SITE	Plant
1	2956	SANTA ANA ST	Front	1		VACANT SITE	Plant
1	2966	SANTA ANA ST	Front	1		VACANT SITE	Plant
1	2972	SANTA ANA ST	Front	1		VACANT SITE	Plant
1	2976	SANTA ANA ST	Front	1		VACANT SITE	Plant
1	2976	SANTA ANA ST	Side	1	8101 X EVERGREEN AV	VACANT SITE	Plant
1	2976	SANTA ANA ST	Side	2	8101 X EVERGREEN AV	VACANT SITE	Plant
1	3006	SANTA ANA ST	Front	1		VACANT SITE	Plant
1	3012	SANTA ANA ST	Front	1		VACANT SITE	Plant
1	3016	SANTA ANA ST	Front	1		VACANT SITE	Plant
1	3022	SANTA ANA ST	Front	1		VACANT SITE	Plant
1	3050	SANTA ANA ST	Side	1	8100 X CYPRESS AV	VACANT SITE	Plant
1	3050	SANTA ANA ST	Side	2	8100 X CYPRESS AV	VACANT SITE	Plant
1	3074	SANTA ANA ST	Front	1		VACANT SITE	Plant
1	3102	SANTA ANA ST	Front	1		VACANT SITE	Plant
1	3102	SANTA ANA ST	Side	1	8100 X GARDEN VIEW AV	VACANT SITE	Plant

City of South Gate
Vacant Planting Sites - November 2007

DIST	HOUSE ADDRESS	SIDE	TREE	ON ADDRESS	COMMON NAME	MAINTENANCE	
1	3106	SANTA ANA ST	Front	1		VACANT SITE	Plant
1	3120	SANTA ANA ST	Front	1		VACANT SITE	Plant
1	3124	SANTA ANA ST	Front	1		VACANT SITE	Plant
1	3152	SANTA ANA ST	Front	1		VACANT SITE	Plant
1	3166	SANTA ANA ST	Front	1		VACANT SITE	Plant
1	3200	SANTA ANA ST	Front	1		VACANT SITE	Plant
1	3200	SANTA ANA ST	Side	1	8100 X MADISON AV	VACANT SITE	Plant
1	3216	SANTA ANA ST	Front	1		VACANT SITE	Plant
1	3224	SANTA ANA ST	Front	1		VACANT SITE	Plant
1	3258	SANTA ANA ST	Front	1		VACANT SITE	Plant
1	3266	SANTA ANA ST	Front	1		VACANT SITE	Plant
1	3270	SANTA ANA ST	Front	1		VACANT SITE	Plant
1	3402	SANTA ANA ST	Front	1		VACANT SITE	Plant
1	3402	SANTA ANA ST	Side	1	8100 X ELIZABETH AV	VACANT SITE	Plant
1	3402	SANTA ANA ST	Side	2	8100 X ELIZABETH AV	VACANT SITE	Plant
1	3406	SANTA ANA ST	Front	1		VACANT SITE	Plant
1	3450	SANTA ANA ST	Front	1		VACANT SITE	Plant
1	3452	SANTA ANA ST	Side	1	8100 X VIRGINIA AV	VACANT SITE	Plant
2	3514	SANTA ANA ST	Front	1		VACANT SITE	Plant
2	3520	SANTA ANA ST	Front	1		VACANT SITE	Plant
2	3526	SANTA ANA ST	Side	1	8101 X SAN ANTONIO AV	VACANT SITE	Plant
2	3600	SANTA ANA ST	Side	1	8100 X SAN ANTONIO AV	VACANT SITE	Plant
2	3600	SANTA ANA ST	Side	2	8100 X SAN ANTONIO AV	VACANT SITE	Plant
2	3612	SANTA ANA ST	Front	1		VACANT SITE	Plant
2	3616	SANTA ANA ST	Front	1		VACANT SITE	Plant
2	3620	SANTA ANA ST	Front	1		VACANT SITE	Plant
2	3700	SANTA ANA ST	Front	1		VACANT SITE	Plant
2	3710	SANTA ANA ST	Front	1		VACANT SITE	Plant
2	3716	SANTA ANA ST	Front	1		VACANT SITE	Plant
2	3720	SANTA ANA ST	Front	1		VACANT SITE	Plant
2	3726	SANTA ANA ST	Front	1		VACANT SITE	Plant
2	3820	SANTA ANA ST	Front	1		VACANT SITE	Plant

City of South Gate

Vacant Planting Sites - November 2007

DIST	HOUSE ADDRESS	SIDE	TREE	ON ADDRESS	COMMON NAME	MAINTENANCE
2	3902 SANTA ANA ST	Side	1	8100 X SAN JUAN AV	VACANT SITE	Plant
2	3912 SANTA ANA ST	Front	1		VACANT SITE	Plant
2	3918 SANTA ANA ST	Front	1		VACANT SITE	Plant
2	3924 SANTA ANA ST	Side	2	8101 X SAN LUIS AV	VACANT SITE	Plant
2	4002 SANTA ANA ST	Front	1		VACANT SITE	Plant
2	4016 SANTA ANA ST	Front	1		VACANT SITE	Plant
2	4024 SANTA ANA ST	Side	2	8101 X SAN MIGUEL AV	VACANT SITE	Plant
2	4024 SANTA ANA ST	Side	3	8101 X SAN MIGUEL AV	VACANT SITE	Plant
5	8935 SANTA FE AV	Front	1		VACANT SITE	Plant
5	8941 SANTA FE AV	Front	1		VACANT SITE	Plant
5	8941 SANTA FE AV	Front	2		VACANT SITE	Plant
11	3040 SEMINOLE AV	Front	1		VACANT SITE	Plant
11	3040 SEMINOLE AV	Front	2		VACANT SITE	Plant
11	3160 SEMINOLE AV	Front	1		VACANT SITE	Plant
11	3170 X SEMINOLE AV	Front	1		VACANT SITE	Plant
11	3175 SEMINOLE AV	Front	1		VACANT SITE	Plant
11	3178 SEMINOLE AV	Front	1		VACANT SITE	Plant
11	2822 SEQUOIA DR	Side	1	10301 X STANFORD AV	VACANT SITE	Plant
11	2944 SEQUOIA DR	Front	1		VACANT SITE	Plant
11	3006 SEQUOIA DR	Front	3		VACANT SITE	Plant
11	3007 SEQUOIA DR	Front	2		VACANT SITE	Plant
11	3143 SEQUOIA DR	Front	1		VACANT SITE	Plant
11	3147 SEQUOIA DR	Front	1		VACANT SITE	Plant
12	3268 SEQUOIA DR	Front	1		VACANT SITE	Plant
12	3279 SEQUOIA DR	Front	1		VACANT SITE	Plant
12	3294 SEQUOIA DR	Front	1		VACANT SITE	Plant
12	3317 SEQUOIA DR	Front	1		VACANT SITE	Plant
12	3325 SEQUOIA DR	Front	1		VACANT SITE	Plant
12	3336 SEQUOIA DR	Front	1		VACANT SITE	Plant
12	3341 SEQUOIA DR	Front	1		VACANT SITE	Plant
12	3359 SEQUOIA DR	Front	1		VACANT SITE	Plant
1	8435 X SEVILLE AV	Front	1		VACANT SITE	Plant

City of South Gate
Vacant Planting Sites - November 2007

DIST	HOUSE ADDRESS	SIDE	TREE	ON ADDRESS	COMMON NAME	MAINTENANCE	
1	8115	SOUTH GATE AV	Front	1		VACANT SITE	Plant
1	8141	SOUTH GATE AV	Front	1		VACANT SITE	Plant
1	8145	SOUTH GATE AV	Front	1		VACANT SITE	Plant
1	8161	SOUTH GATE AV	Front	1		VACANT SITE	Plant
1	8163	SOUTH GATE AV	Front	1		VACANT SITE	Plant
1	8173	SOUTH GATE AV	Front	1		VACANT SITE	Plant
1	8180	SOUTH GATE AV	Front	1		VACANT SITE	Plant
1	8184	SOUTH GATE AV	Side	1	3125 X INDEPENDENCE AV	VACANT SITE	Plant
1	8408	SOUTH GATE AV	Front	1		VACANT SITE	Plant
1	8420	SOUTH GATE AV	Side	1	3151 X POST ST	VACANT SITE	Plant
1	8420	SOUTH GATE AV	Side	2	3151 X POST ST	VACANT SITE	Plant
1	8444	SOUTH GATE AV	Front	1		VACANT SITE	Plant
1	8448	SOUTH GATE AV	Front	1		VACANT SITE	Plant
3	8603	SOUTH GATE AV	Side	2	3130 X ARDMORE AV	VACANT SITE	Plant
3	8608	SOUTH GATE AV	Front	1		VACANT SITE	Plant
3	8609	SOUTH GATE AV	Front	1		VACANT SITE	Plant
3	8640	SOUTH GATE AV	Front	1		VACANT SITE	Plant
3	8648	SOUTH GATE AV	Front	1		VACANT SITE	Plant
3	8676	SOUTH GATE AV	Front	1		VACANT SITE	Plant
6	8900	SOUTH GATE AV	Front	1		VACANT SITE	Plant
6	8941	SOUTH GATE AV	Front	1		VACANT SITE	Plant
6	8959	SOUTH GATE AV	Front	1		VACANT SITE	Plant
6	8978	SOUTH GATE AV	Front	1		VACANT SITE	Plant
5	2414	SOUTHERN AV	Front	1		VACANT SITE	Plant
5	2432	SOUTHERN AV	Front	1		VACANT SITE	Plant
5	2450	SOUTHERN AV	Front	1		VACANT SITE	Plant
5	2464	SOUTHERN AV	Front	1		VACANT SITE	Plant
5	2504	SOUTHERN AV	Front	1		VACANT SITE	Plant
5	2516	SOUTHERN AV	Front	1		VACANT SITE	Plant
5	2558	SOUTHERN AV	Front	1		VACANT SITE	Plant
5	2764	SOUTHERN AV	Front	1		VACANT SITE	Plant
5	2804	SOUTHERN AV	Front	1		VACANT SITE	Plant

City of South Gate

Vacant Planting Sites - November 2007

DIST	HOUSE ADDRESS	SIDE	TREE	ON ADDRESS	COMMON NAME	MAINTENANCE
5	2850	SOUTHERN AV	Front	1	VACANT SITE	Plant
5	2860	SOUTHERN AV	Front	1	VACANT SITE	Plant
8	3078	SOUTHERN AV	Side	2	9201 X GARDEN VIEW AV	Plant
6	3116	SOUTHERN AV	Front	1	VACANT SITE	Plant
6	3128	SOUTHERN AV	Front	1	VACANT SITE	Plant
6	3360	SOUTHERN AV	Front	1	VACANT SITE	Plant
7	3720	SOUTHERN AV	Front	1	VACANT SITE	Plant
7	4877	SOUTHERN LN	Front	1	VACANT SITE	Plant
7	4907	SOUTHERN LN	Front	1	VACANT SITE	Plant
5	9211	STANFORD AV	Front	1	VACANT SITE	Plant
5	9215	STANFORD AV	Front	1	VACANT SITE	Plant
5	9222	STANFORD AV	Front	1	VACANT SITE	Plant
5	9437	STANFORD AV	Side	1	2845 X OHIO AV	Plant
5	9518	STANFORD AV	Front	1	VACANT SITE	Plant
5	9703	STANFORD AV	Side	1	2840 X MISSOURI AV	Plant
5	9804	STANFORD AV	Front	1	VACANT SITE	Plant
5	9815	STANFORD AV	Front	1	VACANT SITE	Plant
11	10006	STANFORD AV	Front	1	VACANT SITE	Plant
11	10025	STANFORD AV	Front	1	VACANT SITE	Plant
11	10028	STANFORD AV	Front	1	VACANT SITE	Plant
11	10031	STANFORD AV	Front	1	VACANT SITE	Plant
11	10040	STANFORD AV	Side	2	2901 X WISCONSIN AV	Plant
11	10102	STANFORD AV	Side	2	2900 X WISCONSIN AV	Plant
11	10139	STANFORD AV	Front	1	VACANT SITE	Plant
11	10144	STANFORD AV	Front	1	VACANT SITE	Plant
11	10151	STANFORD AV	Front	1	VACANT SITE	Plant
11	10212	STANFORD AV	Front	1	VACANT SITE	Plant
11	10236	STANFORD AV	Front	1	VACANT SITE	Plant
11	10242	STANFORD AV	Front	1	VACANT SITE	Plant
11	10255	STANFORD AV	Side	1	2825 X SEQUOIA DR	Plant
11	10347	STANFORD AV	Front	1	VACANT SITE	Plant
11	10409	STANFORD AV	Front	1	VACANT SITE	Plant

City of South Gate
Vacant Planting Sites - November 2007

DIST	HOUSE ADDRESS	SIDE	TREE	ON ADDRESS	COMMON NAME	MAINTENANCE
11	10433 STANFORD AV	Front	1		VACANT SITE	Plant
11	10451 STANFORD AV	Front	1		VACANT SITE	Plant
11	10508 STANFORD AV	Side	1	2840 X SEMINOLE AV	VACANT SITE	Plant
11	10508 STANFORD AV	Side	2	2840 X SEMINOLE AV	VACANT SITE	Plant
11	10601 STANFORD AV	Front	1		VACANT SITE	Plant
11	10607 STANFORD AV	Front	1		VACANT SITE	Plant
11	10619 STANFORD AV	Front	1		VACANT SITE	Plant
1	8431 STATE ST	Side	3	3200 X POST ST	VACANT SITE	Plant
1	8431 STATE ST	Side	4	3200 X POST ST	VACANT SITE	Plant
1	8455 STATE ST	Front	2		VACANT SITE	Plant
3	8601 STATE ST	Front	2		VACANT SITE	Plant
3	8619 STATE ST	Front	1		VACANT SITE	Plant
3	8631 STATE ST	Front	1		VACANT SITE	Plant
3	8650 STATE ST	Front	1		VACANT SITE	Plant
3	8660 STATE ST	Front	1		VACANT SITE	Plant
6	8936 STATE ST	Front	1		VACANT SITE	Plant
6	8948 STATE ST	Front	1		VACANT SITE	Plant
6	8951 STATE ST	Front	1		VACANT SITE	Plant
6	8979 STATE ST	Front	1		VACANT SITE	Plant
8	9300 STATE ST	Front	1		VACANT SITE	Plant
8	9315 X STATE ST	Front	1		VACANT SITE	Plant
8	9315 X STATE ST	Front	2		VACANT SITE	Plant
8	9511 STATE ST	Front	1		VACANT SITE	Plant
8	9514 STATE ST	Front	1		VACANT SITE	Plant
8	9519 STATE ST	Front	1		VACANT SITE	Plant
8	9523 STATE ST	Front	1		VACANT SITE	Plant
8	9537 STATE ST	Front	1		VACANT SITE	Plant
8	9544 STATE ST	Front	1		VACANT SITE	Plant
8	9548 STATE ST	Front	1		VACANT SITE	Plant
8	9552 STATE ST	Front	1		VACANT SITE	Plant
8	9556 STATE ST	Front	1		VACANT SITE	Plant
8	9605 STATE ST	Front	2		VACANT SITE	Plant

City of South Gate

Vacant Planting Sites - November 2007

DIST	HOUSE ADDRESS	SIDE	TREE	ON ADDRESS	COMMON NAME	MAINTENANCE
8	9628 STATE ST	Side	1	3201 X MISSOURI AV	VACANT SITE	Plant
8	9628 STATE ST	Side	2	3201 X MISSOURI AV	VACANT SITE	Plant
8	9628 STATE ST	Side	3	3201 X MISSOURI AV	VACANT SITE	Plant
11	10401 STATE ST	Front	1		VACANT SITE	Plant
11	10500 STATE ST	Side	2	3200 X SEMINOLE AV	VACANT SITE	Plant
16	10518 STONY BROOK AV	Front	1		VACANT SITE	Plant
16	10522 STONY BROOK AV	Front	1		VACANT SITE	Plant
16	10523 STONY BROOK AV	Front	1		VACANT SITE	Plant
16	10528 STONY BROOK AV	Front	1		VACANT SITE	Plant
16	10538 STONY BROOK AV	Front	1		VACANT SITE	Plant
16	10539 STONY BROOK AV	Front	1		VACANT SITE	Plant
16	10544 STONY BROOK AV	Front	1		VACANT SITE	Plant
16	10545 STONY BROOK AV	Front	1		VACANT SITE	Plant
16	10549 STONY BROOK AV	Front	1		VACANT SITE	Plant
16	10554 STONY BROOK AV	Front	1		VACANT SITE	Plant
16	10558 STONY BROOK AV	Front	1		VACANT SITE	Plant
17	5730 TAFT AV	Front	1		VACANT SITE	Plant
17	5750 TAFT AV	Front	1		VACANT SITE	Plant
17	5751 TAFT AV	Side	1	11515 X CENTER ST	VACANT SITE	Plant
17	5751 TAFT AV	Side	2	11515 X CENTER ST	VACANT SITE	Plant
17	5756 TAFT AV	Front	1		VACANT SITE	Plant
11	3154 TECUMSEH AV	Front	2		VACANT SITE	Plant
11	3180 TECUMSEH AV	Front	1		VACANT SITE	Plant
11	3183 TECUMSEH AV	Front	1		VACANT SITE	Plant
11	3186 TECUMSEH AV	Side	2	10601 X STATE ST	VACANT SITE	Plant
11	3214 TECUMSEH AV	Front	1		VACANT SITE	Plant
11	3225 TECUMSEH AV	Front	1		VACANT SITE	Plant
11	3231 X TECUMSEH AV	Front	2		VACANT SITE	Plant
12	3379 TECUMSEH AV	Side	1	10535 X ELIZABETH AV	VACANT SITE	Plant
12	3384 TECUMSEH AV	Front	1		VACANT SITE	Plant
11	3151 TENAYA AV	Front	3		VACANT SITE	Plant
12	3369 TENAYA AV	Front	1		VACANT SITE	Plant

City of South Gate
Vacant Planting Sites - November 2007

DIST	HOUSE ADDRESS	SIDE	TREE	ON ADDRESS	COMMON NAME	MAINTENANCE
12	3375 TENAYA AV	Side	1	10375 X ELIZABETH AV	VACANT SITE	Plant
12	3376 TENAYA AV	Side	2	10401 X ELIZABETH AV	VACANT SITE	Plant
12	3403 TENAYA AV	Side	1	10380 X ELIZABETH AV	VACANT SITE	Plant
12	3404 TENAYA AV	Front	2		VACANT SITE	Plant
12	3411 TENAYA AV	Front	1		VACANT SITE	Plant
12	3450 TENAYA AV	Front	1		VACANT SITE	Plant
12	3450 TENAYA AV	Front	2		VACANT SITE	Plant
12	3468 TENAYA AV	Front	1		VACANT SITE	Plant
12	3490 TENAYA AV	Front	1		VACANT SITE	Plant
12	3490 TENAYA AV	Side	1	10401 X CALIFORNIA AV	VACANT SITE	Plant
13	3516 TENAYA AV	Front	1		VACANT SITE	Plant
13	3518 TENAYA AV	Front	1		VACANT SITE	Plant
13	3611 TENAYA AV	Front	1		VACANT SITE	Plant
13	3618 TENAYA AV	Front	1		VACANT SITE	Plant
13	3716 TENAYA AV	Front	1		VACANT SITE	Plant
13	3831 TENAYA AV	Front	1		VACANT SITE	Plant
13	3925 TENAYA AV	Front	1		VACANT SITE	Plant
13	4060 TENAYA AV	Front	1		VACANT SITE	Plant
13	4060 TENAYA AV	Front	2		VACANT SITE	Plant
13	4165 TENAYA AV	Front	1		VACANT SITE	Plant
13	4228 TENAYA AV	Front	1		VACANT SITE	Plant
14	5115 TENAYA AV	Front	1		VACANT SITE	Plant
14	5119 TENAYA AV	Front	1		VACANT SITE	Plant
14	5121 TENAYA AV	Front	1		VACANT SITE	Plant
5	8918 TOPE AV	Front	1		VACANT SITE	Plant
5	8939 TOPE AV	Front	1		VACANT SITE	Plant
5	8943 TOPE AV	Front	1		VACANT SITE	Plant
5	8947 TOPE AV	Front	1		VACANT SITE	Plant
5	8969 TOPE AV	Front	1		VACANT SITE	Plant
5	8978 TOPE AV	Side	1	2545 X GLENWOOD PL	VACANT SITE	Plant
5	8978 TOPE AV	Side	2	2545 X GLENWOOD PL	VACANT SITE	Plant
5	9209 TRUBA AV	Front	1		VACANT SITE	Plant

City of South Gate

Vacant Planting Sites - November 2007

DIST	HOUSE ADDRESS	SIDE	TREE	ON ADDRESS	COMMON NAME	MAINTENANCE
5	9219 TRUBA AV	Front	1		VACANT SITE	Plant
5	9232 TRUBA AV	Front	1		VACANT SITE	Plant
5	9319 TRUBA AV	Front	1		VACANT SITE	Plant
5	9525 TRUBA AV	Front	1		VACANT SITE	Plant
5	9537 TRUBA AV	Side	1	2581 X KANSAS AV	VACANT SITE	Plant
5	9630 TRUBA AV	Front	1		VACANT SITE	Plant
5	9633 TRUBA AV	Front	1		VACANT SITE	Plant
5	9737 TRUBA AV	Front	1		VACANT SITE	Plant
5	9802 TRUBA AV	Side	1	2600 X INDIANA AV	VACANT SITE	Plant
5	9802 TRUBA AV	Side	2	2600 X INDIANA AV	VACANT SITE	Plant
5	2585 TWEEDY BL	Side	1	9901 X TRUBA AV	VACANT SITE	Plant
5	2585 TWEEDY BL	Side	2	9901 X TRUBA AV	VACANT SITE	Plant
11	2828 TWEEDY BL	Side	1	9901 X STANFORD AV	VACANT SITE	Plant
11	2904 TWEEDY BL	Side	1	9900 X STANFORD AV	VACANT SITE	Plant
11	2904 TWEEDY BL	Side	2	9900 X STANFORD AV	VACANT SITE	Plant
5	2914 TWEEDY BL	Front	1		VACANT SITE	Plant
5	2922 TWEEDY BL	Front	1		VACANT SITE	Plant
11	2924 TWEEDY BL	Side	1	9901 X SAN ANSELMO AV	VACANT SITE	Plant
11	2924 TWEEDY BL	Side	2	9901 X SAN ANSELMO AV	VACANT SITE	Plant
5	2940 X TWEEDY BL	Front	1		VACANT SITE	Plant
5	2940 X TWEEDY BL	Front	2		VACANT SITE	Plant
5	3006 TWEEDY BL	Front	1		VACANT SITE	Plant
5	3044 X TWEEDY BL	Front	1		VACANT SITE	Plant
11	3050 TWEEDY BL	Side	1	9901 X CAPISTRANO AV	VACANT SITE	Plant
11	3100 TWEEDY BL	Side	1	9900 X CAPISTRANO AV	VACANT SITE	Plant
11	3100 TWEEDY BL	Side	2	9900 X CAPISTRANO AV	VACANT SITE	Plant
8	3296 TWEEDY BL	Front	1		VACANT SITE	Plant
8	3310 TWEEDY BL	Front	1		VACANT SITE	Plant
8	3330 TWEEDY BL	Front	1		VACANT SITE	Plant
8	3361 TWEEDY BL	Side	1	9845 X ELIZABETH AV	VACANT SITE	Plant
8	3361 TWEEDY BL	Side	2	9845 X ELIZABETH AV	VACANT SITE	Plant
8	3433 TWEEDY BL	Side	1	9845 X VIRGINIA AV	VACANT SITE	Plant

City of South Gate
Vacant Planting Sites - November 2007

DIST	HOUSE ADDRESS	SIDE	TREE	ON ADDRESS	COMMON NAME	MAINTENANCE
8	3467 TWEEDY BL	Front	1		VACANT SITE	Plant
9	3605 TWEEDY BL	Side	1	9840 X SAN ANTONIO AV	VACANT SITE	Plant
9	3925 TWEEDY BL	Front	1		VACANT SITE	Plant
9	4035 TWEEDY BL	Front	1		VACANT SITE	Plant
13	4040 TWEEDY BL	Side	1	9901 X SAN MIGUEL AV	VACANT SITE	Plant
13	4100 TWEEDY BL	Side	2	9900 X SAN VICENTE AV	VACANT SITE	Plant
9	4116 TWEEDY BL	Front	1		VACANT SITE	Plant
13	4190 TWEEDY BL	Side	2	9901 X OTIS ST	VACANT SITE	Plant
13	4240 TWEEDY BL	Side	1	9901 X MCNERNEY AV	VACANT SITE	Plant
13	4300 TWEEDY BL	Side	1	9900 X MCNERNEY AV	VACANT SITE	Plant
13	4340 TWEEDY BL	Side	2	9901 X BOWMAN AV	VACANT SITE	Plant
13	4354 TWEEDY BL	Side	1	9900 X BOWMAN AV	VACANT SITE	Plant
10	4434 TWEEDY BL	Front	2		VACANT SITE	Plant
10	4476 TWEEDY BL	Front	8		VACANT SITE	Plant
10	4523 TWEEDY BL	Front	2		VACANT SITE	Plant
10	4533 TWEEDY BL	Front	1		VACANT SITE	Plant
10	4550 TWEEDY BL	Front	2		VACANT SITE	Plant
10	4555 TWEEDY BL	Front	1		VACANT SITE	Plant
10	4555 TWEEDY BL	Side	1	9850 X DOROTHY AV	VACANT SITE	Plant
10	4555 TWEEDY BL	Side	2	9850 X DOROTHY AV	VACANT SITE	Plant
10	4562 TWEEDY BL	Front	1		VACANT SITE	Plant
10	4573 TWEEDY BL	Front	1		VACANT SITE	Plant
10	4576 TWEEDY BL	Front	1		VACANT SITE	Plant
10	4583 TWEEDY BL	Front	1		VACANT SITE	Plant
10	4606 TWEEDY BL	Front	1		VACANT SITE	Plant
14	4606 TWEEDY BL	Side	1	9900 X KAUFFMAN AV	VACANT SITE	Plant
10	4614 TWEEDY BL	Front	1		VACANT SITE	Plant
10	4615 TWEEDY BL	Front	1		VACANT SITE	Plant
10	4623 TWEEDY BL	Front	1		VACANT SITE	Plant
10	4630 TWEEDY BL	Front	1		VACANT SITE	Plant
14	4630 TWEEDY BL	Side	1	9901 X ANNETTA AV	VACANT SITE	Plant
14	4630 TWEEDY BL	Side	2	9901 X ANNETTA AV	VACANT SITE	Plant

City of South Gate

Vacant Planting Sites - November 2007

DIST	HOUSE ADDRESS	SIDE	TREE	ON ADDRESS	COMMON NAME	MAINTENANCE
10	4633 TWEEDY BL	Front	1		VACANT SITE	Plant
10	4633 TWEEDY BL	Side	1	9835 X ANNETTA AV	VACANT SITE	Plant
10	4633 TWEEDY BL	Side	2	9835 X ANNETTA AV	VACANT SITE	Plant
10	4655 TWEEDY BL	Front	1		VACANT SITE	Plant
10	4665 TWEEDY BL	Front	1		VACANT SITE	Plant
10	4674 TWEEDY BL	Front	2		VACANT SITE	Plant
14	4682 TWEEDY BL	Side	1	9901 X HILDRETH AV	VACANT SITE	Plant
10	4830 X TWEEDY BL	Front	1		VACANT SITE	Plant
14	4908 TWEEDY BL	Side	2	9900 X WALNUT AV	VACANT SITE	Plant
10	4936 TWEEDY BL	Front	1		VACANT SITE	Plant
10	4954 TWEEDY BL	Front	3		VACANT SITE	Plant
14	4986 TWEEDY BL	Side	1	9901 X PINEHURST AV	VACANT SITE	Plant
14	4986 TWEEDY BL	Side	2	9901 X PINEHURST AV	VACANT SITE	Plant
17	11323 UTAH AV	Front	1		VACANT SITE	Plant
17	11510 UTAH AV	Front	1		VACANT SITE	Plant
17	11526 UTAH AV	Front	1		VACANT SITE	Plant
17	11611 UTAH AV	Front	1		VACANT SITE	Plant
17	11620 UTAH AV	Front	1		VACANT SITE	Plant
17	11630 UTAH AV	Front	1		VACANT SITE	Plant
17	11725 UTAH AV	Side	1	5625 X MCKINLEY AV	VACANT SITE	Plant
17	11903 UTAH AV	Front	1		VACANT SITE	Plant
17	12004 UTAH AV	Front	1		VACANT SITE	Plant
17	12014 UTAH AV	Front	1		VACANT SITE	Plant
17	12111 UTAH AV	Front	1		VACANT SITE	Plant
17	12112 UTAH AV	Front	1		VACANT SITE	Plant
17	12160 UTAH AV	Side	1	5645 X CENTURY BL	VACANT SITE	Plant
17	12160 UTAH AV	Side	2	5645 X CENTURY BL	VACANT SITE	Plant
1	8111 VICTORIA AV	Front	1		VACANT SITE	Plant
1	8129 VICTORIA AV	Front	1		VACANT SITE	Plant
1	8153 VICTORIA AV	Front	1		VACANT SITE	Plant
1	8160 VICTORIA AV	Front	1		VACANT SITE	Plant
1	8164 VICTORIA AV	Front	1		VACANT SITE	Plant

City of South Gate
Vacant Planting Sites - November 2007

DIST	HOUSE ADDRESS	SIDE	TREE	ON ADDRESS	COMMON NAME	MAINTENANCE
1	8165 VICTORIA AV	Front	1		VACANT SITE	Plant
1	8168 VICTORIA AV	Front	1		VACANT SITE	Plant
1	8185 VICTORIA AV	Front	1		VACANT SITE	Plant
1	8413 X VICTORIA AV	Front	1		VACANT SITE	Plant
1	8422 VICTORIA AV	Front	1		VACANT SITE	Plant
6	8944 VICTORIA AV	Front	1		VACANT SITE	Plant
6	8951 VICTORIA AV	Front	1		VACANT SITE	Plant
6	8983 VICTORIA AV	Front	1		VACANT SITE	Plant
6	8989 VICTORIA AV	Front	1		VACANT SITE	Plant
8	9210 VICTORIA AV	Front	1		VACANT SITE	Plant
8	9301 VICTORIA AV	Front	1		VACANT SITE	Plant
8	9304 VICTORIA AV	Front	1		VACANT SITE	Plant
8	9332 VICTORIA AV	Front	2		VACANT SITE	Plant
8	9417 VICTORIA AV	Side	1	3325 X DUANE WY	VACANT SITE	Plant
8	9417 VICTORIA AV	Side	2	3325 X DUANE WY	VACANT SITE	Plant
8	9420 VICTORIA AV	Side	1	3345 X DUANE WY	VACANT SITE	Plant
8	9420 VICTORIA AV	Side	2	3345 X DUANE WY	VACANT SITE	Plant
8	9530 VICTORIA AV	Front	1		VACANT SITE	Plant
8	9535 VICTORIA AV	Front	1		VACANT SITE	Plant
8	9538 VICTORIA AV	Front	1		VACANT SITE	Plant
8	9601 VICTORIA AV	Front	1		VACANT SITE	Plant
8	9624 VICTORIA AV	Front	1		VACANT SITE	Plant
8	9825 X VICTORIA AV	Front	3		VACANT SITE	Plant
1	8101 X VIRGINIA AV	Front	1		VACANT SITE	Plant
1	8101 X VIRGINIA AV	Front	2		VACANT SITE	Plant
1	8114 VIRGINIA AV	Front	1		VACANT SITE	Plant
1	8115 VIRGINIA AV	Front	1		VACANT SITE	Plant
1	8122 VIRGINIA AV	Front	1		VACANT SITE	Plant
1	8124 VIRGINIA AV	Front	1		VACANT SITE	Plant
1	8128 VIRGINIA AV	Front	1		VACANT SITE	Plant
1	8132 VIRGINIA AV	Front	1		VACANT SITE	Plant
1	8136 VIRGINIA AV	Front	1		VACANT SITE	Plant

City of South Gate

Vacant Planting Sites - November 2007

DIST	HOUSE ADDRESS	SIDE	TREE	ON ADDRESS	COMMON NAME	MAINTENANCE
1	8140 VIRGINIA AV	Front	1		VACANT SITE	Plant
1	8147 VIRGINIA AV	Front	1		VACANT SITE	Plant
1	8147 VIRGINIA AV	Front	2		VACANT SITE	Plant
1	8148 VIRGINIA AV	Front	1		VACANT SITE	Plant
1	8162 VIRGINIA AV	Front	1		VACANT SITE	Plant
1	8166 VIRGINIA AV	Front	1		VACANT SITE	Plant
1	8195 X VIRGINIA AV	Front	1		VACANT SITE	Plant
1	8401 X VIRGINIA AV	Front	2		VACANT SITE	Plant
1	8412 VIRGINIA AV	Front	1		VACANT SITE	Plant
1	8426 VIRGINIA AV	Front	1		VACANT SITE	Plant
1	8480 VIRGINIA AV	Side	1	3455 X INDEPENDENCE AV	VACANT SITE	Plant
1	8480 VIRGINIA AV	Side	2	3455 X INDEPENDENCE AV	VACANT SITE	Plant
3	8612 VIRGINIA AV	Front	1		VACANT SITE	Plant
3	8616 VIRGINIA AV	Front	1		VACANT SITE	Plant
3	8642 VIRGINIA AV	Front	1		VACANT SITE	Plant
3	8651 VIRGINIA AV	Front	1		VACANT SITE	Plant
3	8681 VIRGINIA AV	Front	1		VACANT SITE	Plant
6	8912 VIRGINIA AV	Front	1		VACANT SITE	Plant
6	8916 VIRGINIA AV	Front	1		VACANT SITE	Plant
6	8956 VIRGINIA AV	Front	1		VACANT SITE	Plant
6	8969 X VIRGINIA AV	Front	1		VACANT SITE	Plant
6	8987 VIRGINIA AV	Front	1		VACANT SITE	Plant
6	8993 VIRGINIA AV	Front	1		VACANT SITE	Plant
8	9304 VIRGINIA AV	Front	1		VACANT SITE	Plant
8	9400 VIRGINIA AV	Front	1		VACANT SITE	Plant
8	9410 VIRGINIA AV	Front	1		VACANT SITE	Plant
8	9501 VIRGINIA AV	Side	2	3430 X DUANE WY	VACANT SITE	Plant
8	9519 VIRGINIA AV	Front	1		VACANT SITE	Plant
8	9542 VIRGINIA AV	Front	1		VACANT SITE	Plant
8	9550 VIRGINIA AV	Front	1		VACANT SITE	Plant
8	9559 VIRGINIA AV	Front	1		VACANT SITE	Plant
8	9644 VIRGINIA AV	Side	4	3455 X MISSOURI AV	VACANT SITE	Plant

City of South Gate
Vacant Planting Sites - November 2007

DIST	HOUSE ADDRESS	SIDE	TREE	ON ADDRESS	COMMON NAME	MAINTENANCE
8	9717 VIRGINIA AV	Front	1		VACANT SITE	Plant
8	9738 VIRGINIA AV	Front	2		VACANT SITE	Plant
8	9831 VIRGINIA AV	Front	1		VACANT SITE	Plant
8	9837 VIRGINIA AV	Front	1		VACANT SITE	Plant
12	9915 X VIRGINIA AV	Front	1		VACANT SITE	Plant
12	9932 VIRGINIA AV	Front	2		VACANT SITE	Plant
12	10104 VIRGINIA AV	Front	1		VACANT SITE	Plant
12	10109 VIRGINIA AV	Front	1		VACANT SITE	Plant
12	10112 VIRGINIA AV	Front	1		VACANT SITE	Plant
12	10115 VIRGINIA AV	Front	1		VACANT SITE	Plant
12	10130 X VIRGINIA AV	Front	1		VACANT SITE	Plant
12	10140 VIRGINIA AV	Front	1		VACANT SITE	Plant
12	10141 VIRGINIA AV	Side	1	3435 X MICHIGAN AV	VACANT SITE	Plant
12	10141 VIRGINIA AV	Side	2	3435 X MICHIGAN AV	VACANT SITE	Plant
12	10205 VIRGINIA AV	Front	1		VACANT SITE	Plant
12	10223 VIRGINIA AV	Front	1		VACANT SITE	Plant
12	10246 VIRGINIA AV	Front	1		VACANT SITE	Plant
12	10304 VIRGINIA AV	Front	1		VACANT SITE	Plant
12	10321 VIRGINIA AV	Front	1		VACANT SITE	Plant
12	10418 VIRGINIA AV	Front	2		VACANT SITE	Plant
12	10434 VIRGINIA AV	Front	1		VACANT SITE	Plant
12	10508 VIRGINIA AV	Front	1		VACANT SITE	Plant
12	10515 VIRGINIA AV	Front	1		VACANT SITE	Plant
12	10516 VIRGINIA AV	Front	1		VACANT SITE	Plant
12	10519 VIRGINIA AV	Front	1		VACANT SITE	Plant
12	10521 VIRGINIA AV	Front	1		VACANT SITE	Plant
12	10525 VIRGINIA AV	Front	1		VACANT SITE	Plant
12	10526 VIRGINIA AV	Front	1		VACANT SITE	Plant
12	10539 VIRGINIA AV	Front	1		VACANT SITE	Plant
7	8915 X VOSSLER AV	Front	1		VACANT SITE	Plant
7	8925 VOSSLER AV	Front	1		VACANT SITE	Plant
7	8934 VOSSLER AV	Front	1		VACANT SITE	Plant

City of South Gate

Vacant Planting Sites - November 2007

DIST	HOUSE ADDRESS	SIDE	TREE	ON ADDRESS	COMMON NAME	MAINTENANCE
7	8948 VOSSLER AV	Side	1	8935 X MAY CT	VACANT SITE	Plant
7	8948 VOSSLER AV	Side	2	8935 X MAY CT	VACANT SITE	Plant
7	8954 VOSSLER AV	Front	1		VACANT SITE	Plant
7	8961 VOSSLER AV	Front	1		VACANT SITE	Plant
7	8966 VOSSLER AV	Front	1		VACANT SITE	Plant
7	8972 VOSSLER AV	Front	1		VACANT SITE	Plant
7	8973 VOSSLER AV	Front	1		VACANT SITE	Plant
7	8976 VOSSLER AV	Front	1		VACANT SITE	Plant
7	8977 VOSSLER AV	Front	1		VACANT SITE	Plant
7	8984 VOSSLER AV	Front	1		VACANT SITE	Plant
7	8985 VOSSLER AV	Front	1		VACANT SITE	Plant
7	8995 VOSSLER AV	Front	1		VACANT SITE	Plant
14	10005 WALNUT AV	Front	1		VACANT SITE	Plant
14	10017 WALNUT AV	Front	1		VACANT SITE	Plant
14	10128 WALNUT AV	Front	1		VACANT SITE	Plant
14	10135 WALNUT AV	Side	1	4865 X MICHIGAN AV	VACANT SITE	Plant
14	10206 WALNUT AV	Side	1	4870 X MICHIGAN AV	VACANT SITE	Plant
14	10207 WALNUT AV	Side	1	4860 X MICHIGAN AV	VACANT SITE	Plant
14	10207 WALNUT AV	Side	2	4860 X MICHIGAN AV	VACANT SITE	Plant
14	10242 WALNUT AV	Front	1		VACANT SITE	Plant
14	10300 WALNUT AV	Front	1		VACANT SITE	Plant
14	10337 WALNUT AV	Front	1		VACANT SITE	Plant
14	10340 WALNUT AV	Front	1		VACANT SITE	Plant
14	10347 WALNUT AV	Side	2	4865 X TENAYA AV	VACANT SITE	Plant
14	10406 WALNUT AV	Side	1	4870 X TENAYA AV	VACANT SITE	Plant
14	10406 WALNUT AV	Side	2	4870 X TENAYA AV	VACANT SITE	Plant
14	10600 WALNUT AV	Front	1		VACANT SITE	Plant
14	10601 WALNUT AV	Front	1		VACANT SITE	Plant
14	10005 WASHINGTON AV	Front	1		VACANT SITE	Plant
14	10132 WASHINGTON AV	Front	1		VACANT SITE	Plant
14	10132 WASHINGTON AV	Side	1	4801 X MICHIGAN AV	VACANT SITE	Plant
14	10137 WASHINGTON AV	Side	1	4765 X MICHIGAN AV	VACANT SITE	Plant

City of South Gate
Vacant Planting Sites - November 2007

DIST	HOUSE ADDRESS	SIDE	TREE	ON ADDRESS	COMMON NAME	MAINTENANCE
14	10137 WASHINGTON AV	Side	2	4765 X MICHIGAN AV	VACANT SITE	Plant
14	10206 WASHINGTON AV	Side	1	4800 X MICHIGAN AV	VACANT SITE	Plant
14	10206 WASHINGTON AV	Side	2	4800 X MICHIGAN AV	VACANT SITE	Plant
14	10206 WASHINGTON AV	Side	3	4800 X MICHIGAN AV	VACANT SITE	Plant
14	10246 WASHINGTON AV	Front	1		VACANT SITE	Plant
14	10320 WASHINGTON AV	Front	1		VACANT SITE	Plant
14	10341 WASHINGTON AV	Front	1		VACANT SITE	Plant
14	10415 WASHINGTON AV	Front	1		VACANT SITE	Plant
14	10520 WASHINGTON AV	Front	1		VACANT SITE	Plant
14	10524 WASHINGTON AV	Front	1		VACANT SITE	Plant
14	10528 WASHINGTON AV	Front	1		VACANT SITE	Plant
14	10529 WASHINGTON AV	Front	1		VACANT SITE	Plant
5	2707 WILLOW PL	Front	1		VACANT SITE	Plant
5	2708 WILLOW PL	Side	2	9000 X SANTA FE AV	VACANT SITE	Plant
5	2720 WILLOW PL	Front	1		VACANT SITE	Plant
5	2725 WILLOW PL	Front	1		VACANT SITE	Plant
5	2729 WILLOW PL	Front	1		VACANT SITE	Plant
5	2764 WILLOW PL	Front	1		VACANT SITE	Plant
5	2765 WILLOW PL	Front	1		VACANT SITE	Plant
5	2793 WILLOW PL	Front	1		VACANT SITE	Plant
5	2812 WILLOW PL	Front	1		VACANT SITE	Plant
5	2815 WILLOW PL	Front	1		VACANT SITE	Plant
6	2935 WILLOW PL	Side	1	8925 X EVERGREEN AV	VACANT SITE	Plant
17	5750 WILSON AV	Front	1		VACANT SITE	Plant
17	5785 X WILSON AV	Front	1		VACANT SITE	Plant
17	5785 X WILSON AV	Front	2		VACANT SITE	Plant
18	5934 WILSON AV	Front	1		VACANT SITE	Plant
18	5945 WILSON AV	Front	1		VACANT SITE	Plant
18	5945 WILSON AV	Side	1	11825 X MCKINLEY AV	VACANT SITE	Plant
18	6001 WILSON AV	Side	2	11820 X ARIZONA AV	VACANT SITE	Plant
18	6031 WILSON AV	Front	1		VACANT SITE	Plant
18	6037 WILSON AV	Front	1		VACANT SITE	Plant

City of South Gate

Vacant Planting Sites - November 2007

DIST	HOUSE ADDRESS	SIDE	TREE	ON ADDRESS	COMMON NAME	MAINTENANCE
18	6066 WILSON AV	Front	1		VACANT SITE	Plant
18	6067 WILSON AV	Front	1		VACANT SITE	Plant
18	6147 WILSON AV	Front	1		VACANT SITE	Plant
18	6153 WILSON AV	Front	1		VACANT SITE	Plant
18	6157 WILSON AV	Front	1		VACANT SITE	Plant
11	3001 X WISCONSIN AV	Front	2		VACANT SITE	Plant
11	3001 X WISCONSIN AV	Front	4		VACANT SITE	Plant
11	3008 WISCONSIN AV	Front	1		VACANT SITE	Plant
11	3116 WISCONSIN AV	Front	1		VACANT SITE	Plant
11	3117 WISCONSIN AV	Front	1		VACANT SITE	Plant
11	3128 WISCONSIN AV	Side	2	10101 X SAN JOSE AV	VACANT SITE	Plant
12	3287 WISCONSIN AV	Front	1		VACANT SITE	Plant
12	3301 WISCONSIN AV	Front	1		VACANT SITE	Plant
12	3317 WISCONSIN AV	Front	1		VACANT SITE	Plant
12	3321 WISCONSIN AV	Front	1		VACANT SITE	Plant
12	3324 WISCONSIN AV	Front	1		VACANT SITE	Plant
12	3360 WISCONSIN AV	Front	1		VACANT SITE	Plant
12	3364 WISCONSIN AV	Front	1		VACANT SITE	Plant
12	3368 WISCONSIN AV	Front	1		VACANT SITE	Plant
12	3371 WISCONSIN AV	Front	1		VACANT SITE	Plant
12	3374 WISCONSIN AV	Side	1	10101 X ELIZABETH AV	VACANT SITE	Plant
12	3374 WISCONSIN AV	Side	2	10101 X ELIZABETH AV	VACANT SITE	Plant
12	3374 WISCONSIN AV	Side	3	10101 X ELIZABETH AV	VACANT SITE	Plant
12	3375 WISCONSIN AV	Side	1	10035 X ELIZABETH AV	VACANT SITE	Plant
10	5123 WOOD AV	Front	1		VACANT SITE	Plant
10	5126 WOOD AV	Front	1		VACANT SITE	Plant
10	5131 WOOD AV	Front	1		VACANT SITE	Plant
10	5135 WOOD AV	Front	1		VACANT SITE	Plant
10	5139 WOOD AV	Front	1		VACANT SITE	Plant
10	5142 WOOD AV	Front	1		VACANT SITE	Plant
10	5151 WOOD AV	Front	1		VACANT SITE	Plant
10	5155 WOOD AV	Front	1		VACANT SITE	Plant

City of South Gate
Vacant Planting Sites - November 2007

DIST	HOUSE ADDRESS	SIDE	TREE	ON ADDRESS	COMMON NAME	MAINTENANCE
10	5158 WOOD AV	Front	1		VACANT SITE	Plant
10	5162 WOOD AV	Front	1		VACANT SITE	Plant
10	5163 WOOD AV	Front	1		VACANT SITE	Plant
10	5166 WOOD AV	Front	1		VACANT SITE	Plant
10	5167 WOOD AV	Front	1		VACANT SITE	Plant
10	5171 WOOD AV	Front	1		VACANT SITE	Plant
10	5174 WOOD AV	Front	1		VACANT SITE	Plant
10	5175 WOOD AV	Front	1		VACANT SITE	Plant
10	5178 WOOD AV	Front	1		VACANT SITE	Plant
10	5182 WOOD AV	Front	1		VACANT SITE	Plant
10	5186 WOOD AV	Front	1		VACANT SITE	Plant
10	5187 WOOD AV	Front	1		VACANT SITE	Plant
10	5190 WOOD AV	Front	1		VACANT SITE	Plant
10	5191 WOOD AV	Front	1		VACANT SITE	Plant
10	5194 WOOD AV	Side	2	9801 X ADELLA AV	VACANT SITE	Plant
10	5195 WOOD AV	Front	1		VACANT SITE	Plant
10	5195 WOOD AV	Side	1	9735 X ADELLA AV	VACANT SITE	Plant
10	5204 WOOD AV	Front	1		VACANT SITE	Plant
10	5204 WOOD AV	Side	2	9800 X ADELLA AV	VACANT SITE	Plant
10	5207 WOOD AV	Front	1		VACANT SITE	Plant
10	5208 WOOD AV	Front	1		VACANT SITE	Plant
10	5211 WOOD AV	Front	1		VACANT SITE	Plant
10	5214 WOOD AV	Front	1		VACANT SITE	Plant
10	5223 WOOD AV	Front	1		VACANT SITE	Plant
10	5226 WOOD AV	Front	1		VACANT SITE	Plant
10	5230 WOOD AV	Front	1		VACANT SITE	Plant
10	5231 WOOD AV	Front	1		VACANT SITE	Plant
10	5234 WOOD AV	Front	1		VACANT SITE	Plant
10	5235 WOOD AV	Front	1		VACANT SITE	Plant
10	5243 WOOD AV	Front	1		VACANT SITE	Plant
10	5246 WOOD AV	Front	1		VACANT SITE	Plant
10	5247 WOOD AV	Front	1		VACANT SITE	Plant

City of South Gate

Vacant Planting Sites - November 2007

DIST	HOUSE ADDRESS	SIDE	TREE	ON ADDRESS	COMMON NAME	MAINTENANCE
10	5250 WOOD AV	Front	1		VACANT SITE	Plant
10	5263 WOOD AV	Front	1		VACANT SITE	Plant
14	10521 WRIGHT RD	Front	1		VACANT SITE	Plant
14	10615 X WRIGHT RD	Front	1		VACANT SITE	Plant
14	10700 X WRIGHT RD	Front	1		VACANT SITE	Plant
14	10700 X WRIGHT RD	Front	2		VACANT SITE	Plant
14	10700 X WRIGHT RD	Front	3		VACANT SITE	Plant
14	10700 X WRIGHT RD	Front	4		VACANT SITE	Plant
14	10700 X WRIGHT RD	Front	5		VACANT SITE	Plant
14	10700 X WRIGHT RD	Front	6		VACANT SITE	Plant
14	10700 X WRIGHT RD	Front	7		VACANT SITE	Plant
14	10709 WRIGHT RD	Front	1		VACANT SITE	Plant
14	10713 WRIGHT RD	Front	1		VACANT SITE	Plant
14	10731 WRIGHT RD	Front	1		VACANT SITE	Plant
14	10737 WRIGHT RD	Front	1		VACANT SITE	Plant
14	10743 WRIGHT RD	Front	1		VACANT SITE	Plant
14	10803 WRIGHT RD	Front	1		VACANT SITE	Plant
14	10803 WRIGHT RD	Side	1	5160 X PENDLETON AV	VACANT SITE	Plant
14	10809 WRIGHT RD	Front	1		VACANT SITE	Plant

City of South Gate

2006 Tree Inventory Statistics

Frequency Reports

TREE DIAMETER in inches	COUNT	PERCENT
Vacant planting sites	3,635	19.85%
0-6	4,884	26.68%
7-12	3,802	20.77%
13-18	3,238	17.69%
19-24	1,652	9.02%
25-30	839	4.58%
>30	258	1.41%
	18,308	100.00%

Diameter Frequency

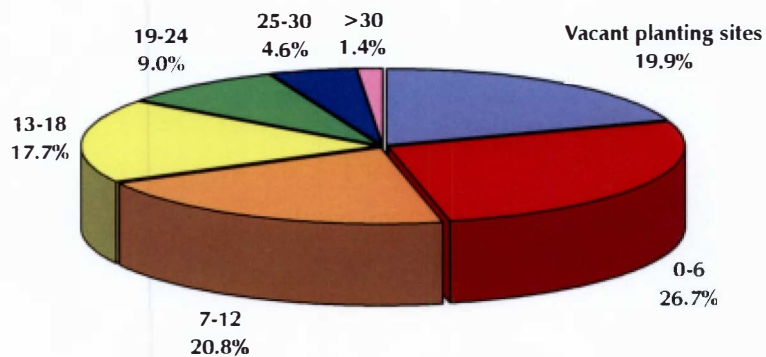

TREE HEIGHT in feet	COUNT	PERCENT
Vacant sites and stumps	3,833	20.94%
1-15	5,264	28.75%
16-30	4,523	24.71%
31-45	2,676	14.62%
46-60	1,539	8.41%
>60	473	2.58%
	18,308	100.00%

Height Frequency

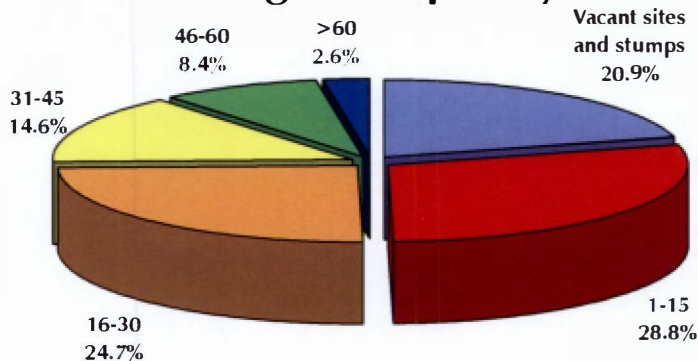

RECOMMENDED MAINTENANCE	COUNT	PERCENT
Grid trimming	14,100	77.02%
Plant	3,635	19.85%
REMOVALS:		
Diseased or declining	348	1.90%
Poorly structured	17	0.09%
Seedling or volunteer	2	0.01%
Spacing criteria	8	0.04%
Stumps	198	1.08%
	18,308	100.00%

Recommended Removals

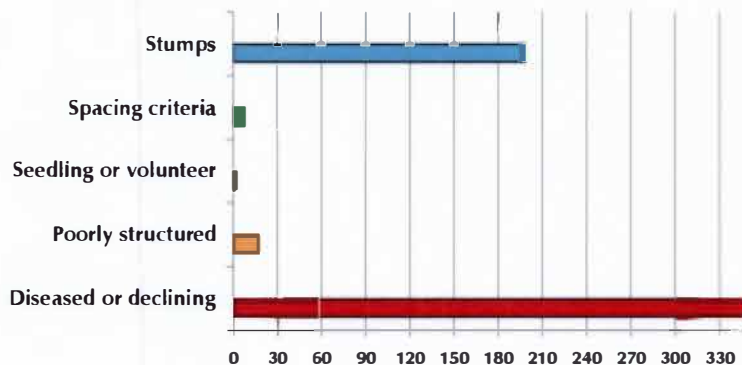



City of South Gate

Department of Public Works

8650 CALIFORNIA AVENUE • SOUTH GATE, CA 90280-3075 • (323) 357-9657
FAX (323) 563-9572

Date: _____

Resident
Address
South Gate, CA 90280

RE: Municipal Tree Planting

Dear Resident:

The City of South Gate is beginning a reforestation campaign. We will be planting a street tree at your address within the next couple of weeks. If you do not want a tree planted, please return the enclosed postcard by _____. The tree species we have designated will be a _____. The selection was made based upon the City of South Gate's Master Street Tree Plan. We also considered the performance and history of this species in the City and the characteristics specific to that tree such as growing space, root structure and general resistance to insects and disease.

We trust you will be pleased with your new tree. Trees beautify our City, increase property value and enhance community safety. The City maintains street trees, but we ask that you take the responsibility of watering your tree as needed. After the planting has been completed, you will receive an educational door hanger that will explain procedures for proper care and maintenance of your new tree.

Thank you for your time and cooperation. Please call _____ at 323 357-9657 if you have any questions.

Sincerely,

Enclosures



City of South Gate

Department of Public Works

8650 CALIFORNIA AVENUE • SOUTH GATE, CA 90280-3075 • (323) 357-9657
FAX (323) 563-9572

Fecha: _____

Residente
Dirección
South Gate, CA 90280

RE: Plantación de Árboles

Estimado Residente:

La Ciudad de South Gate esta iniciando una campana de forestación. Estaremos plantando un árbol de calle en su domicilio dentro de las siguientes semanas. Si usted no quiere que se plante un árbol, por favor retorne la tarjeta que se encuentra dentro del sobre antes del _____. Si no recibimos la tarjeta, la especie de árbol que plantaremos será un _____. Esta elección se baso en el Plan Maestro de Árboles de Calle de la Ciudad de South Gate. También se considera el funcionamiento y la historia de esta especie dentro de la ciudad y las características específicas del árbol, como el espacio de crecimiento necesario, la estructura de las raíces y la resistencia general que tenga contra insectos y enfermedades.

Confiamos que usted estará contento con su árbol nuevo. Los árboles embellecen nuestra ciudad, incrementan el valor de la propiedad y mejoran la seguridad de la comunidad. La ciudad mantiene los árboles de la calle, pero le pedimos que tome la responsabilidad de regarlos cuando sea necesario. Después de que la plantación termine, usted recibirá un colgante en su puerta con información educativa que explicara el cuidado y mantenimiento adecuado para su árbol nuevo.

Gracias por su tiempo y cooperación. Si usted tiene alguna pregunta o inquietud por favor comuníquese con _____ al numero 323- 357-9657.

Sinceramente,

**CITY OF SOUTH GATE
TREE PLANTING
CIUDAD DE SOUTH GATE
PROYECTO PARA PLANTAR ÁRBOLES**

If you do not want to have a tree planted in front of your residence please fill out and return the attached self-addressed card by:

Si usted no quiere que se plante un árbol enfrente de su residencia, por favor complete y regrese esta tarjeta antes de:

- No, Please do not plant a parkway tree in front of my residence.
- No, Por Favor no quiero que planten un árbol enfrente de mi residencia.

Address _____
Direccion _____

**CITY OF SOUTH GATE
TREE PLANTING
CIUDAD DE SOUTH GATE
PROYECTO PARA PLANTAR ÁRBOLES**

If you do not want to have a tree planted in front of your residence please fill out and return the attached self-addressed card by:

Si usted no quiere que se plante un árbol enfrente de su residencia, por favor complete y regrese esta tarjeta antes de:

- No, Please do not plant a parkway tree in front of my residence.
- No, Por Favor no quiero que planten un árbol enfrente de mi residencia.

Address _____
Direccion _____

**CITY OF SOUTH GATE
TREE PLANTING
CIUDAD DE SOUTH GATE
PROYECTO PARA PLANTAR ÁRBOLES**

If you do not want to have a tree planted in front of your residence please fill out and return the attached self-addressed card by:

Si usted no quiere que se plante un árbol enfrente de su residencia, por favor complete y regrese esta tarjeta antes de:

- No, Please do not plant a parkway tree in front of my residence.
- No, Por Favor no quiero que planten un árbol enfrente de mi residencia.

Address _____
Direccion _____

**CITY OF SOUTH GATE
TREE PLANTING
CIUDAD DE SOUTH GATE
PROYECTO PARA PLANTAR ÁRBOLES**

If you do not want to have a tree planted in front of your residence please fill out and return the attached self-addressed card by:

Si usted no quiere que se plante un árbol enfrente de su residencia, por favor complete y regrese esta tarjeta antes de:

- No, Please do not plant a parkway tree in front of my residence.
- No, Por Favor no quiero que planten un árbol enfrente de mi residencia.

Address _____
Direccion _____

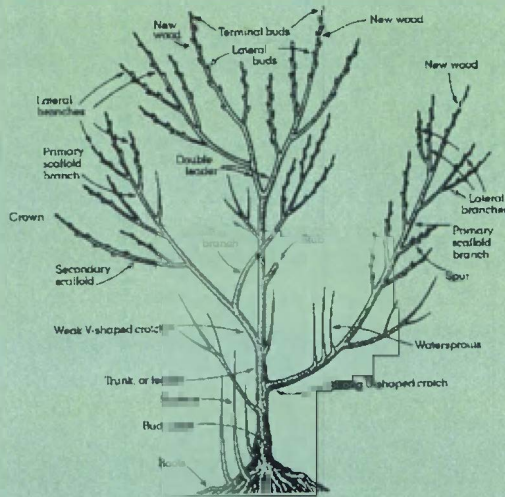

TREE PLANTING NOTICE

In an effort to beautify the City and help the environment, a tree has been planted in your parkway. The tree selected was based on tree performance characteristics such as limb and root structure and general resistance to insects and disease. The planting was completed by West Coast Arborists, the tree care contractor for the City.

The City shall be responsible for all major pruning and any tree surgery that is needed and the control and treatment of insect pests and diseases. However, we ask that you take the responsibility of watering your tree as needed. Here are a few guidelines to follow for proper care and maintenance of your new tree: 1) Do not change the staking; tight staking does not let the tree grow strong. 2) Keep the tree well free of weeds and other plants; they will take nutrients away from the tree. 3) **Fill the tree well with water twice a week; deep watering will promote downward growth of roots and help prevent broken curbs and sidewalk damage.** 4) Keep fertilizer with weed killer at least five to ten feet away from the tree. 5) If a tree needs restaking, please call West Coast Arborists, Inc. at (714)991-1900.

Your cooperation is greatly appreciated in this effort to make your City a beautiful place to live.

ORDINANCE NO. 2009

**CITY OF SOUTH GATE
LOS ANGELES COUNTY, CALIFORNIA**

**AN ORDINANCE OF THE CITY COUNCIL OF THE CITY
OF SOUTH GATE ESTABLISHING CHAPTER 5.33
RELATING TO THE PRESERVATION AND PROTECTION
OF TREES WITHIN THE CITY.**

WHEREAS, the City of South Gate has a rich, viable, and diverse population of ornamental trees; and

WHEREAS, the existence of healthy trees within the City improves the health and welfare of the community, and

WHEREAS, trees enhance property values and community esthetics, and reduce noise and air pollution; and

WHEREAS, trees provide energy-saving shade which leads to reduced summer cooling costs, and

WHEREAS, through this Ordinance, the City Council wishes to:

- (1) Establish policies, regulations, and standards to preserve and protect existing public trees, and eliminate indiscriminate damage and destruction of existing public trees; and
- (2) Require the planting of new trees to replace any removed public trees; and
- (3) Provide for the planting of a required number of trees on public properties near newly planned or renovated commercial and residential properties, as they currently or may hereafter exist, within the City of South Gate;

**NOW, THEREFORE, THE CITY COUNCIL OF THE CITY OF SOUTH GATE
DOES HEREBY RESOLVE AS FOLLOWS:**

SECTION 1. Title 5 of the South Gate Municipal Code is hereby amended by adding a new Chapter 5.33 to read as follows:

“Chapter 5.33
TREE PRESERVATION AND PROTECTION

Sections:

5.33.010	Definitions
5.33.020	Jurisdiction and Control
5.33.030	Permit Requirements
5.33.040	Permit Procedure
5.33.050	Appeal Procedure
5.33.060	Tree Protection During Development and Construction
5.33.070	Other Standards
5.33.080	Licensing and Insurance
5.33.090	Enforcement
5.33.100	Violations and Penalties

5.33.010 DEFINITIONS

For the purpose of this Chapter 5.33, unless it is plainly evident from the context that a different meaning is intended, the following words or phrases shall mean:

1. **“Arborist”** - a person who is accredited by the Western Chapter of the International Society of Arboriculture, or a contractor licensed by the State of California who has demonstrated tree work that complies with the standards of the Western Chapter of International Society of Arboriculture.
2. **“Construction related activities”** - activities including, but not limited to, the storage of materials, grade changes and trenching or attachment of wire or spikes to or around tree trunks, stems or limbs.
3. **“Damage”(verb)** - any action of natural or artificial means, which causes injury, death, or disfigurement to a public tree. This includes, but is not limited to, excessive pruning and/or cutting, poisoning, over- or under-watering, relocating or transplanting a protected tree without a permit, or trenching, excavating or paving or the storage of materials or soil compaction within the protected zone of a tree or by the attachment of signs or artificial material piercing the bark of the tree by means of nails, spikes or other piercing objects.
4. **“Damage” (noun)** - any condition whether caused by natural or artificial means, which causes injury, death, or disfigurement to a public tree.
5. **“Director of Public Works”** - the Director of Public Works or his/her designee.
6. **“Dripline”**- an imaginary line on the ground corresponding to the furthest extension of the canopy (crown) around the circumference of the tree. Typically, the dripline is not a perfect circle.
7. **“Excessively prune or cut”** - detaching or removing from a protected tree any live branch

or root over one inch (1") in diameter or removing more than fifteen percent (15%) of the total live tree canopy or live root system.

8. **"Parkway"** - the portion of City property located between the sidewalk and the roadway.
9. **"Permit"** - a written document formally authorized by the Public Works Department that grants permission to proceed in the performance of the work defined on the Permit Application.
10. **"Person"** - any natural person, partnership, firm, corporation, contractor, governmental agency or other legal entity.
11. **"Private property"** - land owned by a private interest, and not designated public property.
12. **"Protect(ion)"**- the safeguarding of trees through proper maintenance, pruning, treatment, fertilizing, feeding, and any other necessary means undertaken according to the standards of the Western Chapter International Society of Arboriculture.
13. **"Protected zone"** - the diameter of an area twice the distance from the center of the tree trunk to the farthest edge of the dripline or crown of the tree.
14. **"Public property"** - all lands owned, managed or maintained by the City of South Gate including, but not limited to, public rights-of-way, parkways, easements, street medians, and parks.
15. **"Public tree"** - any single or multi-stemmed plant normally reaching mature heights of fifteen feet (15') or more, regardless of its current level of maturity, with one-half or more of its trunk or branches on or above all public property.
16. **"Relocate"** - the permanent or temporary moving of a public tree from one location to another by any means.
17. **"Remove"** - uprooting, cutting or severing of a tree or any main trunk or limb causing or which may be expected to cause, a tree to die or to be damaged.
18. **"Street fixtures"** - street lights, poles, signs, meters, fire hydrants, and other apparatus affixed to the street, curb, sidewalk, or parkway.
19. **"Tree Inspector"** - the person designated by the Director of Public Works to inspect and enforce provisions of this ordinance.

5.33.020 JURISDICTION AND CONTROL

The City of South Gate shall govern use of all public trees and activities which may affect all public trees now or hereafter existing in the city limits and shall have the power to plant, care for, maintain, remove, relocate, prune or cut, and replace said public trees and undertake or permit actions in the protected zone of said public trees.

5.33.030 PERMIT REQUIREMENTS

1. **Requirements**

No person, but for a person undertaking official business for the City of South Gate, shall plant, remove, relocate, damage, excessively prune or cut, or encroach into the protected zone or any public tree within the City of South Gate without first obtaining a permit from the Director of Public Works and paying the required fee. No such permit shall be valid for a period greater than ninety (90) days after the date of its issuance and shall thereafter be null and void unless extended in writing by the Director of Public Works.

2. **Permit Fees**

Permit fees shall be established by the City Council and set forth in the "South Gate Fee Resolution" (Resolution No. 5010), which is kept on file in the office of the City Clerk.

3. **Interference**

No person shall interfere with the legal planting, maintenance, removal and relocation of a public tree or interfere with any legal activity in the protected zone.

4. **Exemptions**

A permit by a peace officer, fire fighter, civil defense official or public utility worker engaged in his/her official capacity is not required to plant, remove, relocate, damage, excessively prune or cut, or encroach into the protected zone of any public tree in an emergency or disaster situation. The Director of Public Works shall be notified of the nature of the emergency and action(s) taken within three (3) days after the action.

A permit is not required to remove dead branches, limbs or trees. However, prior to removal, the branch, limb, or tree must be confirmed by the Tree Inspector to be dead.

5.33.040 PERMIT PROCEDURE

1. Upon application for a permit to plant, remove, relocate, damage, excessively prune or cut, or encroach into the protected zone of any public tree, the Tree Inspector shall investigate the site and prepare a written report evaluating the request. The Director of Public Works shall consider the report, public comments, or any other relevant information and either grant or deny the permit.
2. The Director of Public Works may grant the permit to plant, remove, relocate, damage, excessively prune or cut, or encroach into the protected zone of any public tree, if the applicant has established to the Director of Public Work's satisfaction that the person

conducting the work is qualified to perform the proposed work and that, based on the Tree Inspector's written report, one of the following conditions exists:

- (a) The public tree is so diseased, infested with insects, or damaged that it is no longer viable or is a threat to other trees or plant species, public health or public safety.
- (b) The public tree or a portion thereof is in danger of falling and creates a potential safety hazard;
- (c) The public tree creates a visibility impairment to vehicular traffic or emergency vehicle clearance, obstructs pedestrian traffic, interferes with overhead or underground utilities, interferes with other public or private trees, interferes with street fixtures or is causing damage to hardscape surfaces or a structure, *and* corrective action to reduce the hazard would seriously disfigure the tree or if the continuing cost of repeated corrections would outweigh the value of the tree;
- (d) The public tree creates an unreasonable hardship on the property owner by preventing the economic enjoyment of the property or construction of a proposed legal structure, or by denying a property right possessed by other property owners in the same vicinity and zone;
- (e) When necessary to perform required improvements within public, utility or flood control right-of-way;
- (f) When necessary to protect or maintain a water pipeline, natural gas line, electric power or communication overhead line or other public utility property;
- (g) When an Arborist or other person qualified to make such an assessment, determines a population of trees is creating excessive fuel load posing a potential fire hazard.

3. The Director of Public Works may, in his/her sole discretion, deny a permit to plant, remove, relocate, damage, excessively prune or cut, or encroach into the protected zone of any public tree, if based upon the Tree Inspector's report or other available information, none of the conditions described in Subsection 2 (a) through (g) above is found to exist and if one of the following conditions is found to exist:

- (a) The proposed work will destroy or seriously injure a public tree;
- (b) The species of the public tree is desirable and valuable, or the individual public tree has historical significance;
- (c) The proposed tree work will substantially reduce the shade, wind protection, or air pollution mitigation for an area will negatively affect the esthetics or general welfare of the neighborhood, or will result in soil erosion, or negatively affect soil retention, water retention or the flow of surface water;

- (d) The public tree could be preserved by proper pruning, maintenance and/or relocation;
 - (e) The public tree is required to be preserved by any precise plan or other City approved plan; or
 - (f) Granting the permit would not be in the best interests of the City.
4. Prior to the removing or relocating any public tree, a courtesy notice of such proposed action shall be posted on or near the subject tree for a minimum of ten (10) days prior to the action being carried out. The notice shall include the statement: "This notice is given as a courtesy to the public and the City retains all rights concerning the maintenance of its public trees."
5. The Director of Public Works may impose any condition he/she deems necessary to carry out the purpose and intent of this ordinance. The applicant must bear all costs of performing or executing any condition ordered by the Director of Public Works. No permit shall be issued unless the applicant, in writing, accepts the conditions and agrees to observe same. Conditions may include, but are not limited to, any of the following:
- (a) Replacing the public tree with a tree or trees, including a boxed tree or trees, of a species and size designated by the Director of Public Works;
 - (b) Relocating the public tree to a location approved in writing by the Director of Public Works. Prior to permit issuance a written report from an Arborist shall be submitted to the Director of Public Works describing the relocation method to be used and providing the City with a three (3) year guarantee of survival.
 - (c) Payment of restitution for the public tree in the amount determined by the Director of Public Works;
 - (d) Any other condition the Director of Public Works deems reasonable and appropriate.
6. The Tree Inspector shall investigate the public tree(s) after the permit has been issued to determine whether the terms of this ordinance and any permit conditions were met.

5.33.050 APPEAL PROCEDURE

1. Any applicant who objects to any condition of a permit or who is denied a permit shall have the right to appeal the decision of the Director of Public Works to the City Council provided a written appeal is received by the City Clerk within fifteen (15) calendar days of the date said permit was issued or denied. The appeal shall contain the following:
- (a) Date and signature of the appealing party,
 - (b) Appealing party's typed or printed name, address and telephone number.
 - (c) The property address where the public tree exists, and
 - (d) The reason(s) for the appeal.

2. As soon as practicable after receiving a timely filed appeal, the City Clerk shall set a date for hearing of the appeal by the City Council which date shall not be not more than sixty (60) days from the date the appeal was filed. A written notice of hearing of the appeal shall be served on appellant at least fifteen (15) calendar days prior to the hearing date. Said notice shall state the date, time and location of the appeal hearing. Service shall be made by sending the appealing party the notice of hearing by first class mail, postage prepaid, to the address stated in the appeal. The failure of the appealing party to receive the notice shall not affect the validity of the proceedings.
3. The City Council shall hear and consider all relevant reports, evidence, objections, or protests, and shall receive testimony from the appealing party, witnesses, City personnel and any other interested persons, relative to the appeal. Upon the conclusion of the hearing on such appeal, the City Council shall, by resolution, affirm, reverse or modify the decision of the Director of Public Works in accordance with the evidence presented at the appeal hearing. All decisions of the City Council shall be final and conclusive.

5.33.060 TREE PROTECTION DURING DEVELOPMENT AND CONSTRUCTION

1. The following activities require a permit from the Director of Public Works prior to commencement:
 - (a) Compaction of the soil within the dripline of any public tree.
 - (b) Construction, including structures and walls, that disrupts the root system of any public tree.
 - (c) Cutting roots within the dripline of a public tree.
 - (d) All other grading, construction, or construction related activities occurring within the dripline of a public tree.
2. Trees covered in this ordinance shall be shielded from damage during construction with an appropriate construction barrier enclosing the entire dripline area. Prior to construction activity, the Tree Inspector shall approve the type of barrier to be used. The protective barrier shall be installed prior to any construction activity and removed only upon approval of the Tree Inspector.
3. Tree protection guidelines in the Street Tree Master Plan and this code shall apply unless otherwise permitted by the Director of Public Works.
4. The Director of Public Works may in his/her sole discretion impose additional conditions necessary to preserve or protect any public tree which is located in a construction or development zone.

5.33.070 OTHER STANDARDS

1. **Street Tree Master Plan**
The Director of Public Works shall develop and maintain a Street Tree Master Plan as approved by resolution of the City Council. The Street Tree Master Plan shall include a list

of tree species approved for planting in streets, parkways and other public areas, and rules and regulations governing the planting, location, spacing and maintenance of public trees. All trees to be planted or installed upon any portion of any public property shall conform to the Street Tree Master Plan, unless otherwise specified by a permit issued by the Director of Public Works.

2. **Work Performance**

All persons who maintain, plant, remove, relocate, damage, excessively prune or cut, or encroach into the protected zone of a public tree shall do so in accordance with standards recognized by the Western Chapter of the International Society of Arboriculture.

5.33.080 LICENSING AND INSURANCE

1. But for any person engaged in this activity while in the course of his/her employment with the City of South Gate, and any person engaged in planting, removing, relocating, excessively pruning and cutting, or encroaching into the protected zone, spraying or otherwise treating of any public tree shall produce--prior to commencement of work, and maintain during the period of work activity--evidence of:
 - (a) certification or licensing by a recognized certifier/licensor appropriate for the activity, and
 - (b) public liability and property damage insurance in an amount to be determined by the Public Works Department.
2. The Director of Public Works may also require posting of a performance bond to guarantee the completion of any job in accordance with adopted City standards, rules and regulations. All required evidence of certification/license, insurance and performance bond shall be submitted to the Director of Public Works.

5.33.090 ENFORCEMENT

The Director of Public Works, or designee is hereby charged with the responsibility for the enforcement of this ordinance and may serve notice to any person in violation thereof or institute legal process as may be required.

5.33.100 VIOLATIONS AND PENALTIES

1. Any person who violates any of the provisions of this Chapter 5.33 which violation thereof is considered to be a misdemeanor or an infraction, shall be subject to the fines and/or penalties as set forth in Chapter 1.56 "Penalty Provisions" of this code.
2. Violations of any provisions of this ordinance or any permit, may be required to replace the public tree(s) with a tree(s) of a size, species and condition determined by the Director of Public Works.
3. Any person who plants, removes, relocates, damages, excessively prunes or cuts, or encroaches into the protected zone of any public tree without a permit shall be liable to the

City for a civil penalty in an amount equal to the tree's full restitution value plus the cost of labor and materials to install the public tree.

4. All other permits issued pursuant to this ordinance to a person convicted of a violation of any section of this ordinance or of any permit shall be deemed invalid or held by an official notice to stop work until the penalty for violation has been fulfilled."

SECTION 2. The City Clerk shall attest and certify the passage and adoption of this Ordinance, which shall take full force and effect the date of its adoption.

PASSED, APPROVED and ADOPTED this 13th day of August, 1996.

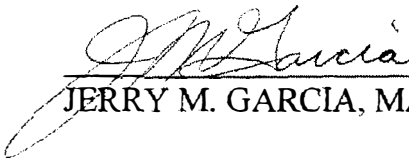

JERRY M. GARCIA, MAYOR

ATTEST:



NINA BANUELOS, CITY CLERK
(SEAL)

APPROVED AS TO FORM:

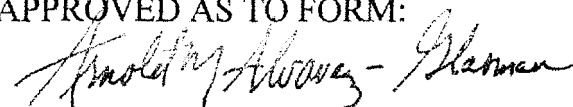

ARNOLD M. ALVAREZ-GLASMAN
CITY ATTORNEY

ORDINANCE CERTIFICATION PAGE

STATE OF CALIFORNIA

COUNTY OF LOS ANGELES, SS.

CITY OF SOUTH GATE

I, NINA BAÑUELOS, City Clerk of the City of South Gate, California, do hereby certify that the whole number of members of the City Council of said City is five; that Ordinance No. 2009 was duly adopted by the City Council at a Regular Meeting of the City Council held on August 13, 1996 by the following vote:

Ayes:	Councilmembers:	Garcia, Martinez, Buckles, Gonzalez, and Robles
Noes:	Councilmembers:	None
Absent:	Councilmembers:	None
Abstain:	Councilmembers:	None

Witness my hand and the seal of said City on August 13, 1996.

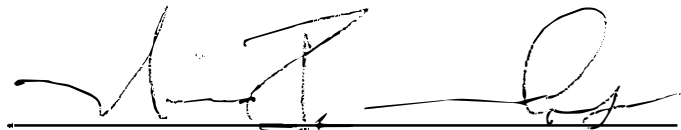

NINA BAÑUELOS, City Clerk
City of South Gate, California

(Seal)

American National Standard

*for Tree Care Operations –
Tree, Shrub and Other Woody
Plant Maintenance –
Standard Practices*

ANSI A300-1995



American National Standards Institute

11 West 42nd Street
New York, New York
10036

Contents

	Page
Foreword.....	ii
1 Scope, purpose, and application	1
2 Normative references	1
3 Definitions	1
4 Safety	4
5 Tree pruning.....	4
Figures	
1 Removing a large lateral branch requires two preliminary cuts before the final cut	6
2 When cutting back to a lateral, bisect the angle between the branch bark ridge and an imaginary line perpendicular to the leader or branch being removed	6
3 When removing a branch with a narrow branch attachment, cut from the bottom upward	6
Annex	
A Bibliography	9

Foreword (This foreword is not part of American National Standard A300-1995.)

This standard was developed under the procedures of the American National Standards Institute by Accredited Standards Committee on Tree, Shrub and Other Woody Plant Maintenance Operations, A300. The National Arborist Association is the secretariat of A300.

Accredited Standards Committee A300 was approved June 28, 1991. The Committee was organized to develop a consensus performance standard for persons engaged in the maintenance of trees, shrubs and other woody plants. The Committee includes representatives from the residential and commercial tree care industry; the utility, municipal, and federal sectors; the landscape and nursery industries; as well as other interested organizations.

The A300 standard currently addresses tree pruning practices only. Subcommittees have been formed to address Construction Protection; Cabling, Bracing, and Guying; Soil Modification/Fertilization; Lightning Protection; Equipment Calibration; Tree Growth Regulators; and Shrub, Vine, and Other Woody Plant Pruning.

Specifications for tree work should be written and administered by an arborist. An arborist is a professional who possesses the technical competence through experience and related training to provide for or supervise the management of trees and other woody plants in the residential, commercial, and public landscape. This A300 standard offers basic performance standards. It is not a guideline to illustrate how to prune trees.

This standard has been drafted to address pruning specification requirements across all geographic areas. The users of this standard must interpret the wording based on their knowledge of the growth habits of certain tree species within a given environment.

Suggestions for improvement of this standard should be forwarded to: A300 Secretariat, c/o National Arborist Association, P.O. Box 1094, Amherst, NH 03031.

This standard was processed and approved for submittal to ANSI by Accredited Standards Committee on Tree, Shrub and Other Woody Plant Maintenance Operations, A300. Committee approval of the standard does not necessarily imply that all committee members voted for its approval. At the time it approved this standard, the A300 committee had the following members:

Tim Johnson, Chairman
(Artistic Arborist, Inc.)
Brian Barnard, Secretary
(National Arborist Association)

<i>Organization Represented</i>	<i>Name of Representative</i>
American Association of Nurserymen.....	Craig J. Regelbrugge Ben Bolusky (Alt.)
American Forests	Cheryl Kollin
American Society of Consulting Arborists.....	Donald F. Blair
American Society of Landscape Architects.....	Karen Niles
Asplundh Tree Expert Company	James D. Beam Dave Morrison (Alt.)
Associated Landscape Contractors of America.....	Preston Leyshon

<i>Organization Represented</i>	<i>Name of Representative</i>
The Davey Tree Expert Company	Edward Johnson Karl Warnke (Alt.)
The F.A. Bartlett Tree Expert Company.....	Greg Daniels
International Society of Arboriculture	John C. Britton Bill Kruidenier (Alt.)
Municipal Arborists & Urban Foresters Society.....	Cathy Riley-Hall
National Arborist Association	Paul McFarland Robert Felix (Alt.)
National Park Service	Robert DeFeo Dick Hammerschlag (Alt.)
Professional Grounds Management Society	John Gillan
Society of Municipal Arborists.....	Dale Gaasland
U.S. Forest Service	Rita Schoeneman Marcia Sneed (Alt.)
Utility Arborist Association	Jeff Smith Mike Watson (Alt.)

ANSI®
A300-1995

American National Standard
for Tree Care Operations –
Tree, Shrub and Other Woody Plant Maintenance –
Standard Practices

Secretariat
National Arborist Association, Inc.

Approved June 1, 1995
American National Standards Institute, Inc.

American National Standard

Approval of an American National Standard requires verification by ANSI that the requirements for due process, consensus, and other criteria for approval have been met by the standards developer.

Consensus is established when, in the judgment of the ANSI Board of Standards Review, substantial agreement has been reached by directly and materially affected interests. Substantial agreement means much more than a simple majority, but not necessarily unanimity. Consensus requires that all views and objections be considered, and that a concerted effort be made toward their resolution.

The use of American National Standards is completely voluntary; their existence does not in any respect preclude anyone, whether he has approved the standards or not, from manufacturing, marketing, purchasing, or using products, processes, or procedures not conforming to the standards.

The American National Standards Institute does not develop standards and will in no circumstances give an interpretation of any American National Standard. Moreover, no person shall have the right or authority to issue an interpretation of an American National Standard in the name of the American National Standards Institute. Requests for interpretations should be addressed to the secretariat or sponsor whose name appears on the title page of this standard.

CAUTION NOTICE: This American National Standard may be revised or withdrawn at any time. The procedures of the American National Standards Institute require that action be taken periodically to reaffirm, revise, or withdraw this standard. Purchasers of American National Standards may receive current information on all standards by calling or writing the American National Standards Institute.

Published by

**American National Standards Institute
11 West 42nd Street, New York, New York 10036**

Copyright ©1995 by American National Standards Institute
All rights reserved.

No part of this publication may be reproduced in any form, in an electronic retrieval system or otherwise, without prior written permission of the publisher.

Printed in the United States of America

APS10M795/18

American National Standard for Tree Care Operations –

Tree, Shrub and Other Woody Plant Maintenance – Standard Practices

1 Scope, purpose, and application

1.1 Scope

This document presents performance standards for the care and maintenance of trees, shrubs, and other woody plants.

1.2 Purpose

It is intended as a guide for federal, state, municipal, and private authorities including property owners, property managers, and utilities in the drafting of their maintenance specifications and should be adopted by them in whole or in part.

1.3 Application

This standard is intended to apply to any person or entity engaged in the business, trade, or performance of repairing, maintaining, or preserving trees.

1.4 Implementation

Specifications for tree work should be written and administered by an arborist.

2 Normative references

The following standards contain provisions which, through reference in this text, constitute provisions of this American National Standard. At the time of publication, the editions indicated were valid. All standards are subject to revision, and parties to agreements based on this American National Standard are encouraged to investigate the possibility of applying the most recent edition of the standards indicated below.

ANSI Z60.1-1990, *Nursery stock*

ANSI Z133.1-1994, *Tree care operations – Pruning, trimming, repairing, maintaining, and removing trees, and cutting brush – Safety requirements*

29 CFR 1910, *General industry*¹⁾

29 CFR 1910.268, *Telecommunications*¹⁾

29 CFR 1910.269, *Electric power generation, transmission, and distribution*¹⁾

29 CFR 1910.331 – 335, *Electrical safety-related work practices*¹⁾

3 Definitions

3.1 anvil-type pruning tool: Pruning tool that has a straight sharp blade that cuts against a flat metal cutting surface. (See *hook and blade-type pruning tool*.)

3.2 arborist: A professional who possesses the technical competence through experience and related training to provide for or supervise the management of trees and other woody plants in the residential, commercial, and public landscape.

3.3 boundary reaction zone: A separating boundary between wood present at the time of wounding and wood that continues to form after wounding.

3.4 branch: A secondary shoot or stem arising from one of the main axes (i.e., trunk or leader) of a tree or woody plant.

¹⁾ Available from U.S. Department of Labor, 200 Constitution Avenue, NW, Washington, DC 20210.

3.5 branch collar: Trunk tissue that forms around the base of a branch between the main stem and the branch or a branch and a lateral. As a branch decreases in vigor or begins to die, the branch collar becomes more pronounced.

3.6 branch bark ridge: Raised area of bark in the branch crotch that marks where the branch wood and trunk wood meet.

3.7 callus: Undifferentiated tissue formed by the cambium layer around a wound.

3.8 cambium: Dividing layer of cells that forms sapwood (xylem) to the inside and bark (phloem) to the outside.

3.9 climbing spurs: Sharp, pointed devices affixed to the climber's leg used to assist in climbing trees (also known as *gaffs, hooks, spurs, spikes, climbers*).

3.10 closure: The process of woundwood covering a cut or other tree injury.

3.11 crotch: The angle formed at the attachment between a branch and another branch, leader, or trunk of a woody plant.

3.12 crown: The leaves and branches of a tree or shrub; the upper portion of a tree from the lowest branch on the trunk to the top.

3.13 crown cleaning: The removal of dead, dying, diseased, crowded, weakly attached, low-vigor branches, and watersprouts from a tree's crown.

3.14 crown raising: The removal of the lower branches of a tree in order to provide clearance.

3.15 crown reduction: The reduction of the top, sides, or individual limbs by the means of removal of the leader or longest portion of a limb to a lateral no less than one-third of the total diameter of the original limb removing no more than one-quarter of the leaf surface.

3.16 crown thinning: The selective removal of branches to increase light penetration and air movement, and to reduce weight.

3.17 cut: The exposed wood area resulting from the removal of a branch or portion thereof.

3.18 decay: Degradation of woody tissue caused by biological organisms.

3.19 espalier pruning: A combination of cutting and training branches that are oriented in one plane, formally or informally arranged,

and usually supported on a wall, fence, or trellis. The patterns can be simple or complex, but the cutting and training is precise. Ties should be replaced every few years to prevent girdling the branches at the attachment site.

3.20 facility: Equipment or structure used to deliver or provide protection for the delivery of an essential service such as electricity.

3.21 girdling roots: Roots located above- or belowground whose circular growth around the base of the trunk or over individual roots applies pressure to the bark area, ultimately restricting sap flow and trunk/root growth, frequently resulting in reduced vitality or stability of the plant.

3.22 heading: Cutting a currently growing or one-year-old shoot back to a bud, or cutting an older branch or stem back to a stub or lateral branch not sufficiently large enough to assume the terminal role. Heading should rarely be used on mature trees.

3.23 heartwood: The inactive xylem (wood) toward the center of a stem or root that provides structural support.

3.24 hook and blade pruning tool: A hand pruner that has a curved, sharpened blade that overlaps a supporting hook; in contrast to an *anvil-type pruning tool*.

3.25 horizontal plane (palms): An imaginary level line that begins at the base of live frond petioles.

3.26 lateral: A branch or twig growing from a parent branch or stem.

3.27 leader: A dominant upright stem, usually the main trunk. There can be several leaders in one tree.

3.28 limb: Same as *branch*, but larger and more prominent.

3.29 lopping: See *heading*.

3.30 mycelium: Growth mass of fungus tissue found under bark or in rotted wood.

3.31 obstructing: To hinder, block, close off, or be in the way of; to hinder or retard a desired effect or shape.

3.32 parent branch or stem: The tree trunk; or a large limb from which lateral branches grow.

3.33 petiole: The stalk of a leaf.

3.34 phloem: Inner bark tissue through which primarily carbohydrates and other organic compounds move from regions of high concentration to low.

3.35 pollarding: Pollarding is a training system used on some large-growing deciduous trees that are severely headed annually or every few years to hold them to modest size or to give them and the landscape a formal appearance. Pollarding is not synonymous with topping, lopping, or stubbing. Pollarding is severely heading some and removing the other vigorous water sprouts back to a definite head or knob of latent buds at the branch ends.

3.36 precut or precutting: The two-step process to remove a branch before the finished cut is made so as to prevent splitting or bark tearing into the parent stem. The branch is first undercut, then cut from the top before the final cut.

3.37 pruning: Removal of plant parts.

3.38 qualified line clearance tree trimmer: A tree worker who, through related training and on-the-job experience is familiar with the techniques in line clearance and has demonstrated his/her ability in the performance of the special techniques involved. This qualified person may or may not be currently employed by a line clearance contractor.

3.39 qualified line clearance tree trimmer trainee: Any worker undergoing line-clearance tree trimming training, who, in the course of such training, is familiar with the techniques in line clearance and has demonstrated his/her ability in the performance of the special techniques involved. Such trainees shall be under the direct supervision of qualified personnel.

3.40 qualified person or personnel: Workers who, through related training, or on-the-job experience, or both, are familiar with the techniques and hazards of arboriculture work including training, trimming, maintaining, repairing, or removing trees, and the equipment used in such operations.

3.41 qualified tree worker, person, or personnel: A person(s) who, through related training and on-the-job experience, is familiar with the hazards of pruning, trimming, repairing, maintaining, or removing trees and with

the equipment used in such operations, and has demonstrated ability in the performance of the special techniques involved.

3.42 qualified tree worker trainee: Any worker undergoing on-the-job training who, in the course of such training, is familiar with the hazards of pruning, trimming, repairing, maintaining, or removing trees, with the equipment used in such operations, and has demonstrated ability in the performance of the special techniques involved. Such trainees shall be under the direct supervision of qualified personnel.

3.43 remote/rural: Areas associated with very little human activity, land improvement, or development.

3.44 sapwood: The active xylem (wood) that stores water and carbohydrates, and transports water and nutrients; a wood layer of variable thickness found immediately inside the cambium, comprised of water-conducting vessels or tracheids and living plant cells.

3.45 shall: As used in this standard, denotes a mandatory requirement.

3.46 should: As used in this standard, denotes an advisory recommendation.

3.47 stub: An undesirable short length of a branch remaining after a break or incorrect pruning cut is made.

3.48 stubbing: See *heading*.

3.49 target: A person, structure, or object that could sustain damage from the failure of a tree or portion of a tree.

3.50 terminal role: Branch that assumes the dominant vertical position on the top of a tree.

3.51 thinning: The removal of a lateral branch at its point of origin or the shortening of a branch or stem by cutting to a lateral large enough to assume the terminal role.

3.52 throwline: A small, lightweight line with a weighted end used to position a climber's rope in a tree.

3.53 topping: See *heading*.

3.54 tracing: Shaping a wound by removing loose bark from in and around a wound.

3.55 urban/residential: Locations normally associated with human activity such as populated areas including public and private property.

3.56 utility: An entity that delivers a public service such as electricity or communication.

3.57 utility space: The physical area occupied by the utility's facilities and the additional space required to ensure its operation.

3.58 wound: The opening that is created any time the tree's protective bark covering is penetrated, cut, or removed, injuring or destroying living tissue. Pruning a live branch creates a wound, even when the cut is properly made.

3.59 woundwood: Differentiated woody tissue that forms after initial callus has formed around the margins of a wound. Wounds are closed primarily by woundwood.

3.60 xylem: Wood tissue; active xylem is called *sapwood*, inactive xylem is called *heartwood*.

3.61 young tree: A tree young in age or a newly installed tree.

4 Safety

4.1 Tree maintenance shall only be performed by qualified tree workers, who through related training, or on-the-job experience, or both, are familiar with the practices and hazards of arboriculture, and the equipment used in such operations.

4.2 This standard shall not take precedence over arboricultural safe work practices.

Operations shall comply with applicable Occupational Safety and Health Administration (OSHA) standards (see clause 2), ANSI Z133.1, as well as state and local regulations.

5 Tree pruning

5.1 Purpose

The purpose of this clause is to provide specifications for tree pruning.

5.2 Pruning practices

5.2.1 Reasons for pruning

The reasons for tree pruning may include, but are not limited to, reducing hazards, maintaining or improving tree health and structure, improving aesthetics, or satisfying a specific

need such as: removing diseased, dead, dying, decayed, interfering or obstructing branches; training young trees; utility line clearance; or specialty tasks as defined in this standard. Before pruning, the primary objective should be clearly defined. That objective should be accomplished in the manner most beneficial to the health of the tree.

Pruning practices for agricultural, horticultural production or silvicultural purposes are exempt from this standard.

5.2.2 When to prune

To obtain the defined objective, the growth cycles of individual species as well as the type of pruning to be performed should be considered.

5.2.3 Tree inspection

Before beginning work and while work is being performed, a qualified person shall visually inspect each tree. If a condition is observed that requires additional attention, this condition should be brought to the attention of an immediate supervisor or the person responsible for authorizing the work.

5.2.4 Tools and equipment

5.2.4.1 Pruning tools used in making pruning cuts shall be kept adequately sharpened to result in final cuts with a smooth surface and firmly attached remaining adjacent bark.

5.2.4.2 Hook and blade pruning tools should be used; not anvil-type pruning tools.

5.2.4.3 Climbing spurs should not be used when climbing trees, except as specified elsewhere in this standard. Climbing spur use is permissible on tree removals and in emergencies such as aerial rescue.

5.2.4.4 Equipment and work practices that damage bark, cambium, live palm tissue, or any combination of these, should be avoided.

5.2.5 Pruning cuts

5.2.5.1 A thinning cut should be the preferred type of cut to make.

5.2.5.2 A thinning cut shall consist of the removal of a lateral branch at its point of origin or the shortening of a branch or stem by cutting to a lateral large enough to assume the terminal role.

5.2.5.3 A heading cut should rarely be used on mature trees, yet may be appropriate for

specific purposes such as, but not limited to, training young trees; pollarding, shaping terminal flowering trees, storm damage repair, etc.

5.2.5.4 A heading cut should consist of cutting a currently growing or one-year-old shoot back to a bud, or cutting an older branch or stem back to a stub or lateral branch not sufficiently large enough to assume the terminal role.

5.2.5.5 When removing a lateral branch at its point of origin on the trunk or parent limb, the final cut shall be made in branch tissue close to the trunk or parent limb, without cutting into the branch bark ridge or collar, or leaving a stub. (See figure 1.)

5.2.5.6 When removing a leader or length of a branch, the angle of the cut should bisect the angle between the branch bark ridge and an imaginary line perpendicular to the leader being removed. (See figure 2.)

5.2.5.7 When removing a dead branch, the final cut shall be made just outside the collar of live tissue. If the collar has grown out along the branch stub, only the dead stub should be removed. The live collar shall remain intact and uninjured.

5.2.5.8 To prevent damage to the parent limb when removing a branch with a narrow branch attachment, the final cut should be made from the bottom of the branch up. (See figure 3.)

5.2.5.9 Cut limbs shall be removed from the crown upon completion of the pruning, or at times when the tree would be left unattended or at the end of the work day.

5.2.6 Wound treatment

5.2.6.1 Wound dressings and tree paints should not be used to cover pruning wounds, except when specified for disease, borer, mistletoe, sprout control, or cosmetic reasons. If wound dressings or paints are used for cosmetic or other reasons, then materials nontoxic to the cambium layer shall be used, and only a light coating shall be applied to the wound surface.

5.2.6.2 When repairing bark wounds, only damaged or loose bark should be removed, disturbing a minimal amount of live tissue.

5.2.6.3 Cavities shall not be filled or treated if the boundary reaction zones would be disturbed.

5.3 Mature tree pruning

5.3.1 General

The following specifications should be used with pruning objectives.

5.3.1.1 Pruning cuts shall be made in accordance with 5.2.5.

5.3.1.2 Tree branches shall be removed in such a manner so as not to cause damage to other parts of the tree or to other plants or property. Branches too large to support with one hand shall be precut to avoid splitting or tearing of the bark. (See figure 1.) Where necessary, ropes or other equipment should be used to lower large branches or portions of branches to the ground.

5.3.1.3 When a branch is cut back to a lateral, not more than one-fourth of its leaf surface should be removed. The lateral remaining should be large enough to assume the terminal role.

5.3.1.4 Not more than one-fourth of the foliage on a mature tree should be removed within a growing season.

5.3.1.5 Upon completion of pruning a mature tree, one-half of the foliage should remain evenly distributed in the lower two-thirds of the crown and individual limbs.

5.3.2 Size specifications

A minimum or maximum diameter of branches to be removed should be specified to establish the extent of pruning, such as: the removal of branches 3 in (7.5 cm) in diameter and greater, or; the removal of branches 2 in (5 cm) in diameter and greater, etc.

5.3.3 Pruning objectives

Pruning objectives should be established prior to beginning any pruning operation.

5.3.3.1 Hazard reduction pruning

Hazard reduction pruning is recommended when the primary objective is to reduce the danger to a specific target caused by visibly defined hazards in a tree. Hazard reduction pruning should consist of one or more of the maintenance pruning types.

5.3.3.2 Maintenance pruning

Maintenance pruning is recommended when the primary objective is to maintain or improve tree

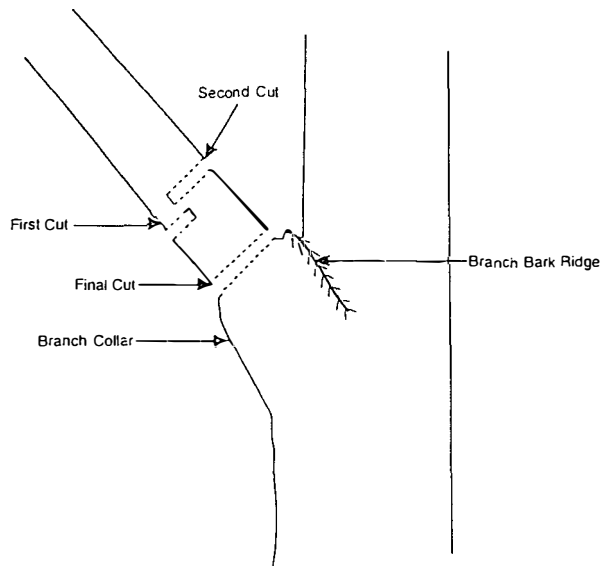

Figure 1 – Removing a large lateral branch requires two preliminary cuts before the final cut

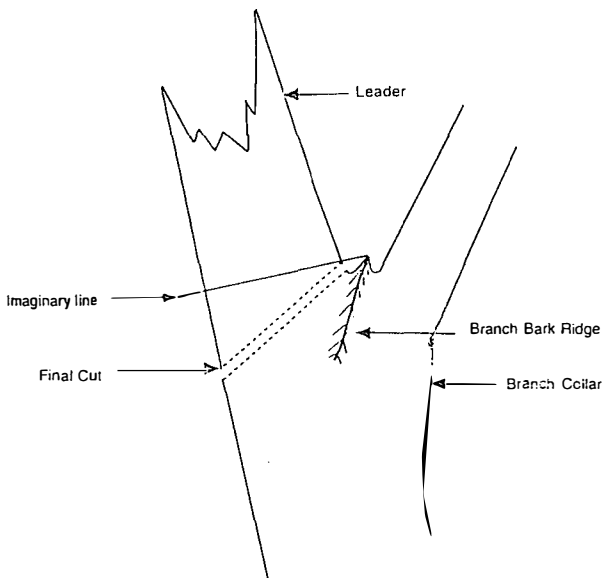

Figure 2 – When cutting back to a lateral, bisect the angle between the branch bark ridge and an imaginary line perpendicular to the leader or the branch being removed

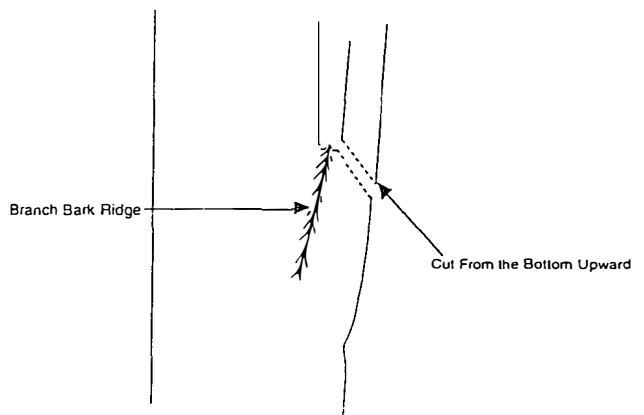

Figure 3 – When removing a branch with a narrow branch attachment, cut from the bottom upward

health and structure, and includes hazard reduction pruning. Maintenance pruning should consist of one or more of the following pruning types:

- a) *Crown cleaning*: Crown cleaning shall consist of the selective removal of one or more of the following items: dead, dying, diseased, weak branches and watersprouts from a tree's crown;
- b) *Crown thinning*: Crown thinning shall consist of the selective removal of branches to increase light penetration, air movement, and reduce weight;
- c) *Crown raising*: Crown raising shall consist of the removal of the lower branches of a tree in order to provide clearance;
- d) *Crown reduction (crown shaping)*: Crown reduction reduces the height and/or spread of a tree. Consideration should be given to the ability of a species to sustain this type of pruning;
- e) *Vista pruning*: Vista pruning is selective thinning of framework limbs or specific areas of the crown to allow a specific view of an object from a predetermined point;
- f) *Crown restoration*: Crown restoration pruning should improve the structure, form, and appearance of trees that have been severely headed, vandalized, or storm damaged.

5.4 Young tree pruning

5.4.1 At planting

When a young tree is planted, dead, broken, and split branches should be removed. A central trunk or leader or well-spaced multiple trunks or leaders (as most appropriate for the species and specimen) should be developed by removing competing leaders and removing, heading, or thinning laterals on vigorously growing branches that compete with the selected leader(s). Branches should be retained on the lower trunk to increase taper.

5.4.2 During the first three years after planting

A strong scaffold branch structure should be developed by selecting the primary scaffold branches. To improve the scaffold structure, branches that are crossing, have included bark, or interfere with the scaffold branches should be removed. Scaffold branches should

be properly spaced. For deciduous shade trees that will reach or exceed 40 ft (12 m) in height at maturity, the recommended spacing between primary scaffold branches is approximately 18 in (46 cm). For smaller species, 6 to 8 in (15 to 20 cm) would be adequate.

5.4.3 Between four and six years after planting

The development of a good, structurally sound scaffold branch system should be continued by selective thinning of or on branches and removing dead, interfering, split, and broken branches. Large-growing branches with narrow angles of attachment shall be removed from the trunk or canopy. Lower branches shall be pruned (crown raising) so as not to interfere with human needs where appropriate.

5.5 Specialty training systems

5.5.1 Espalier

Espalier pruning is a combination of cutting and training branches that are oriented in one plane; formally or informally arranged; and usually supported on a wall, fence, or trellis. The patterns can be simple or complex but the cutting and training is precise. Ties should be replaced every few years to prevent girdling the branches at the attachment site.

5.5.2 Pollarding

Pollarding is a training system used on some large-growing deciduous trees that are severely headed annually or every few years to hold them to modest size or to give them and the landscape a formal appearance. Pollarding is not synonymous with topping, lopping, or stubbing. Pollarding is severely heading some and removing the other vigorous water sprouts back to a definite head or knob of latent buds at the branch ends.

5.6 Palm pruning

5.6.1 Palm pruning should be performed when fronds, fruit, or loose petioles may create a dangerous condition.

5.6.1.1 Live healthy fronds, initiating at an angle of 45° or greater from the horizontal plane, should not be removed.

5.6.1.2 Fronds removed should be severed close to the petiole base without damaging living trunk tissue.

5.6.1.3 Palm peeling (shaving) should consist of the removal of the dead frond bases only, at the point they make contact with the trunk without damaging living trunk tissue.

5.7 Utility pruning

5.7.1 General

The purpose of utility pruning is to remove branches in order to prevent the loss of service, prevent damage to equipment, avoid impairment and uphold the intended usage of the facility/utility space.

5.7.1.1 Only a qualified line clearance tree trimmer or qualified line clearance tree trimmer trainee should be assigned to line clearance work in accordance with ANSI Z133.1, 29 CFR 1910.331 – 335, 29 CFR 1910.268, or 29 CFR 1910.269.

5.7.1.2 Utility pruning operations are exempt from requirements in 5.2.3.

5.7.2 Utility crown reduction pruning

5.7.2.1 Urban/residential environment

5.7.2.1.1 Cuts should be made in accordance with 5.2.5 and 5.2.6.

5.7.2.1.2 A minimum number of cuts should be made to accomplish the purpose of facility/utility pruning. The natural shape of the tree should be considered.

5.7.2.1.3 Trees directly under and growing into the facility/utility should be removed or pruned. Such pruning should be done by removing entire branches or by removing branches that have laterals growing into (or, once pruned, will grow into) the facility/utility space.

5.7.2.1.4 Trees growing along the side and growing into or toward the facility/utility space should be pruned by removing entire branch-

es. Branches that, when cut, will produce sprouts that would grow into facilities and/or utility space should be removed.

5.7.2.1.5 Branches should be cut to laterals or the parent branch and not at a preestablished clearing limit.

5.7.2.2 Remote/rural environment

5.7.2.2.1 Climbing spurs

Climbing spurs may be used when limbs are more than throw line distance apart, or when the bark is thick enough to prevent damage to the cambium, or there are no other practical means of climbing the tree.

5.7.2.2.2 Remote locations

Utilities must often maintain facilities/corridors at remote locations. In such locations, it may be appropriate to use mechanical pruning equipment.

5.7.2.2.3 Mechanical pruning

Cuts should be made close to the main stem, outside of the branch bark ridge and branch collar. Precautions should be taken to avoid stripping or tearing of bark or excessive wounding.

5.7.3 Emergency service restoration

During a utility declared emergency, utilities must restore service as quickly as possible in accordance with ANSI Z133.1, 29 CFR 1910.331 – 335, 29 CFR 1910.268, or 29 CFR 1910.269. At such times it may be necessary, because of safety and the urgency of service restoration, to deviate from the use of proper pruning techniques as defined in this standard. Following the emergency, corrective pruning should be done as necessary.